

# DIVISION MATCH AND ANNUAL RIFLE TRAINING DATABOOK

## M16A4 /M4 SERVICE RIFLE WITH RIFLE COMBAT OPTIC (RCO) AND BACK-UP IRON SIGHT (BUIS)

LAST NAME, INITIALS:		LAST 4:	
UNIT:		BLOOD TYPE:	
WEAPON SERIAL #:		RCO SERIAL #:	
RANGE:	TARGET:	RELAY:	DATE:

COLLIMATOR SETTING						
<table border="1" style="width: 100%; border-collapse: collapse;"> <tr> <td style="width: 50%;">ALPHA</td> <td style="width: 50%;">NUMERIC</td> </tr> <tr> <td style="height: 30px;"></td> <td style="height: 30px;"></td> </tr> </table>	ALPHA	NUMERIC				
ALPHA	NUMERIC					
<b>BUIS BZO</b>	<b>ELEV</b>	<b>WIND</b>				

NAVMC XXXXX (Rev. 01-12) Previous editions are obsolete  
 S/N: XXXX-XXX-XX-XXXX U/I :  
 FOUO: Privacy sensitive when filled in

# DIVISION MATCH AND ANNUAL RIFLE TRAINING DATABOOK

## M16A4 /M4 SERVICE RIFLE WITH RIFLE COMBAT OPTIC (RCO) AND BACK-UP IRON SIGHT (BUIS)

LAST NAME, INITIALS:		LAST 4:	
UNIT:		BLOOD TYPE:	
WEAPON SERIAL #:		RCO SERIAL #:	
RANGE:	TARGET:	RELAY:	DATE:

COLLIMATOR SETTING						
<table border="1" style="width: 100%; border-collapse: collapse;"> <tr> <td style="width: 50%;">ALPHA</td> <td style="width: 50%;">NUMERIC</td> </tr> <tr> <td style="height: 30px;"></td> <td style="height: 30px;"></td> </tr> </table>	ALPHA	NUMERIC				
ALPHA	NUMERIC					
<b>BUIS BZO</b>	<b>ELEV</b>	<b>WIND</b>				

NAVMC XXXXX (Rev. 01-12) Previous editions are obsolete  
 S/N: XXXX-XXX-XX-XXXX U/I :  
 FOUO: Privacy sensitive when filled in

# Rifleman's Creed

THIS IS MY RIFLE.

There are many like it, but this one is mine. My rifle is my best friend. It is my life. I must master it as I must master my life.

My rifle, without me, is useless. Without my rifle, I am useless. I must fire my rifle true. I must shoot straighter than my enemy who is trying to kill me. I must shoot him before he shoots me.  
I will...

My rifle and myself know that what counts in this war is not the rounds we fire, the noise of our burst, nor the smoke we make. We know that it is the hits that count.  
We will hit...

My rifle is human, even as I, because it is my life. Thus, I will learn it as a brother. I will learn its weaknesses, its strength, its parts, its accessories, its sights and its barrel. I will keep my rifle clean and ready, even as I am clean and ready. We will become part of each other.  
We will...

Before God, I swear this creed. My rifle and myself are the defenders of my country. We are the masters of our enemy.  
We are the saviors of my life...

So be it, until victory is America's and there is no enemy, but peace!

*- Major General William H. Rupertus -*

# Rifleman's Creed

THIS IS MY RIFLE.

There are many like it, but this one is mine. My rifle is my best friend. It is my life. I must master it as I must master my life.

My rifle, without me, is useless. Without my rifle, I am useless. I must fire my rifle true. I must shoot straighter than my enemy who is trying to kill me. I must shoot him before he shoots me.  
I will...

My rifle and myself know that what counts in this war is not the rounds we fire, the noise of our burst, nor the smoke we make. We know that it is the hits that count.  
We will hit...

My rifle is human, even as I, because it is my life. Thus, I will learn it as a brother. I will learn its weaknesses, its strength, its parts, its accessories, its sights and its barrel. I will keep my rifle clean and ready, even as I am clean and ready. We will become part of each other.  
We will...

Before God, I swear this creed. My rifle and myself are the defenders of my country. We are the masters of our enemy.  
We are the saviors of my life...

So be it, until victory is America's and there is no enemy, but peace!

*- Major General William H. Rupertus -*

## **SAFETY RULES**

1. TREAT EVERY WEAPON AS IF IT WERE LOADED.
2. NEVER POINT A WEAPON AT ANYTHING YOU DO NOT INTEND TO SHOOT.
3. KEEP YOUR FINGER STRAIGHT AND OFF THE TRIGGER UNTIL YOU ARE READY TO FIRE.
4. KEEP THE WEAPON ON SAFE UNTIL YOU INTEND TO FIRE.

1

## **SAFETY RULES**

1. TREAT EVERY WEAPON AS IF IT WERE LOADED.
2. NEVER POINT A WEAPON AT ANYTHING YOU DO NOT INTEND TO SHOOT.
3. KEEP YOUR FINGER STRAIGHT AND OFF THE TRIGGER UNTIL YOU ARE READY TO FIRE.
4. KEEP THE WEAPON ON SAFE UNTIL YOU INTEND TO FIRE.

1

# WEAPONS HANDLING

WEAPON CONDITIONS	
<b>CONDITION 1</b>	SAFETY ON, MAGAZINE INSERTED, ROUND IN CHAMBER, BOLT FORWARD, EJECTION PORT COVER CLOSED.
<b>CONDITION 2</b>	NOT APPLICABLE TO THE M16A4 RIFLE.
<b>CONDITION 3</b>	SAFETY ON, MAGAZINE INSERTED, CHAMBER EMPTY, BOLT FORWARD, EJECTION PORT COVER CLOSED.
<b>CONDITION 4</b>	SAFETY ON, MAGAZINE REMOVED, CHAMBER EMPTY, BOLT FORWARD, EJECTION PORT COVER CLOSED.

WEAPON COMMANDS	
<b>"MAKE A CONDITION 3 WEAPON"</b>	TAKES THE WEAPON FROM CONDITION 4 TO CONDITION 3
<b>"MAKE A CONDITION 1 WEAPON "</b>	TAKES THE WEAPON FROM CONDITION 3 TO CONDITION 1
<b>"FIRE"</b>	ENGAGE TARGET(S)
<b>"CEASE FIRE"</b>	CEASE TARGET ENGAGEMENT
<b>"MAKE A CONDITION 4 WEAPON"</b>	TAKES THE WEAPON FROM ANY CONDITION TO CONDITION 4
<b>"SHOW CLEAR"</b>	REQUIRES A SECOND INDIVIDUAL TO INSPECT THE WEAPON BEFORE THE WEAPON IS PLACED INTO CONDITION 4

# WEAPONS HANDLING

WEAPON CONDITIONS	
<b>CONDITION 1</b>	SAFETY ON, MAGAZINE INSERTED, ROUND IN CHAMBER, BOLT FORWARD, EJECTION PORT COVER CLOSED.
<b>CONDITION 2</b>	NOT APPLICABLE TO THE M16A4 RIFLE.
<b>CONDITION 3</b>	SAFETY ON, MAGAZINE INSERTED, CHAMBER EMPTY, BOLT FORWARD, EJECTION PORT COVER CLOSED.
<b>CONDITION 4</b>	SAFETY ON, MAGAZINE REMOVED, CHAMBER EMPTY, BOLT FORWARD, EJECTION PORT COVER CLOSED.

WEAPON COMMANDS	
<b>"MAKE A CONDITION 3 WEAPON"</b>	TAKES THE WEAPON FROM CONDITION 4 TO CONDITION 3
<b>"MAKE A CONDITION 1 WEAPON "</b>	TAKES THE WEAPON FROM CONDITION 3 TO CONDITION 1
<b>"FIRE"</b>	ENGAGE TARGET(S)
<b>"CEASE FIRE"</b>	CEASE TARGET ENGAGEMENT
<b>"MAKE A CONDITION 4 WEAPON"</b>	TAKES THE WEAPON FROM ANY CONDITION TO CONDITION 4
<b>"SHOW CLEAR"</b>	REQUIRES A SECOND INDIVIDUAL TO INSPECT THE WEAPON BEFORE THE WEAPON IS PLACED INTO CONDITION 4

## USER SERVICEABILITY INSPECTION

**Perform a user serviceability inspection before beginning live fire to ensure the weapon is in acceptable operating condition. This inspection complements, but does not replace, the pre-fire inspection (PFI) conducted by a qualified armorer. Specific inspection areas are:**

1. Weapon is in Condition 4.
2. Compensator: Centered, and tight.
3. Barrel: Tight.
4. BUIS tightly secured to rail system, adjustable, straight. Front Sight Post: Adjustable, straight, shape.
5. Rail System: No cracks, chips, severe dents, rail covers present, no cracks, not excessively loose.
6. Sighting System: Proper model RCO for weapon, attached correctly/throw levers secured, lenses not cracked, scratched, or broken, and reticle not canted.
7. Stock: Tight on lower receiver, then break weapon down shotgun style.
8. Chamber/barrel: Remove bolt carrier group; clear of obstructions, no major pits or cracks.
9. Gas Tube (from chamber end): Not bent or damaged, uniform shape.
10. Bolt Carrier Group: Properly assembled, rotates freely, gas rings staggered evenly around bolt.
11. Lubrication: Lubricated for operational condition and climate, replace bolt carrier group, and reassemble weapon.

## USER SERVICEABILITY INSPECTION

**Perform a user serviceability inspection before beginning live fire to ensure the weapon is in acceptable operating condition. This inspection complements, but does not replace, the pre-fire inspection (PFI) conducted by a qualified armorer. Specific inspection areas are:**

1. Weapon is in Condition 4.
2. Compensator: Centered, and tight.
3. Barrel: Tight.
4. BUIS tightly secured to rail system, adjustable, straight. Front Sight Post: Adjustable, straight, shape.
5. Rail System: No cracks, chips, severe dents, rail covers present, no cracks, not excessively loose.
6. Sighting System: Proper model RCO for weapon, attached correctly/throw levers secured, lenses not cracked, scratched, or broken, and reticle not canted.
7. Stock: Tight on lower receiver, then break weapon down shotgun style.
8. Chamber/barrel: Remove bolt carrier group; clear of obstructions, no major pits or cracks.
9. Gas Tube (from chamber end): Not bent or damaged, uniform shape.
10. Bolt Carrier Group: Properly assembled, rotates freely, gas rings staggered evenly around bolt.
11. Lubrication: Lubricated for operational condition and climate, replace bolt carrier group, and reassemble weapon.

## FUNCTION CHECK

**A function check is performed after reassembling the rifle to ensure the rifle is operational.**

1. Ensure rifle is in Condition 4.
2. Pull charging handle to rear and release. Ensure selector lever is on SAFE. Move the trigger to the rear – hammer should not fall.
3. Place selector lever on SEMI. Move the trigger to the rear and **hold to rear** – hammer should fall. While holding the trigger to the rear, pull charging handle to rear and release. Release trigger until you hear a “clunk”.
4. Place selector lever on BURST. Move the trigger to the rear and **hold to rear** – hammer should fall. While holding the trigger to the rear, pull charging handle to rear three times and release. Release trigger until you hear a “clunk”, and move to the rear again – hammer should fall.
5. Pull charging handle to rear and release. Place selector lever on SAFE, close ejection port cover.

4

## FUNCTION CHECK

**A function check is performed after reassembling the rifle to ensure the rifle is operational.**

1. Ensure rifle is in Condition 4.
2. Pull charging handle to rear and release. Ensure selector lever is on SAFE. Move the trigger to the rear – hammer should not fall.
3. Place selector lever on SEMI. Move the trigger to the rear and **hold to rear** – hammer should fall. While holding the trigger to the rear, pull charging handle to rear and release. Release trigger until you hear a “clunk”.
4. Place selector lever on BURST. Move the trigger to the rear and **hold to rear** – hammer should fall. While holding the trigger to the rear, pull charging handle to rear three times and release. Release trigger until you hear a “clunk”, and move to the rear again – hammer should fall.
5. Pull charging handle to rear and release. Place selector lever on SAFE, close ejection port cover.

4

## CORRECTIVE ACTION

**Corrective action is the process of identifying the cause of a stoppage, clearing the stoppage, and returning the weapon to operation.**

INDICATOR	CORRECTIVE ACTION
Bolt is forward or ejection port cover closed.	Observe, tap, rack, bang.
Bolt is locked to the rear.	Observe, conduct a speed reload.
Brass is obstructing chamber area. (Usually indicates double feed or failure to eject)	Observe, lock bolt to rear, remove magazine. Clear out the obstruction. Conduct a reload.
Brass stuck above the bolt.	Observe, place the weapon on SAFE, remove the magazine. Hold the bolt face back with a sturdy object while pushing forward on the charging handle to clear obstruction. Conduct reload.
Audible pop (reduced report), reduced recoil, or excessive smoke escaping from the chamber area. (May indicate a bullet is lodged in the bore)	<ul style="list-style-type: none"> <li>- STOP FIRING! Observe, Place weapon in Condition 4.</li> <li>- Push rear take down pin all the way, pivot lower receiver.</li> <li>- Remove bolt carrier.</li> <li>- Inspect bore for obstruction by projectile.</li> <li>- Insert cleaning rod into bore from muzzle end and clear obstruction.</li> <li>- Reload, sight in, and attempt to fire (take weapon to an armorer if in training).</li> </ul>

5

## CORRECTIVE ACTION

**Corrective action is the process of identifying the cause of a stoppage, clearing the stoppage, and returning the weapon to operation.**

INDICATOR	CORRECTIVE ACTION
Bolt is forward or ejection port cover closed.	Observe, tap, rack, bang.
Bolt is locked to the rear.	Observe, conduct a speed reload.
Brass is obstructing chamber area. (Usually indicates double feed or failure to eject)	Observe, lock bolt to rear, remove magazine. Clear out the obstruction. Conduct a reload.
Brass stuck above the bolt.	Observe, place the weapon on SAFE, remove the magazine. Hold the bolt face back with a sturdy object while pushing forward on the charging handle to clear obstruction. Conduct reload.
Audible pop (reduced report), reduced recoil, or excessive smoke escaping from the chamber area. (May indicate a bullet is lodged in the bore)	<ul style="list-style-type: none"> <li>- STOP FIRING! Observe, Place weapon in Condition 4.</li> <li>- Push rear take down pin all the way, pivot lower receiver.</li> <li>- Remove bolt carrier.</li> <li>- Inspect bore for obstruction by projectile.</li> <li>- Insert cleaning rod into bore from muzzle end and clear obstruction.</li> <li>- Reload, sight in, and attempt to fire (take weapon to an armorer if in training).</li> </ul>

5

# 7 COMMON FACTORS OF SHOOTING POSITIONS

**BUTT OF WEAPON HIGH IN POCKET OF SHOULDER** ②

**STOCKWELD AND EYE RELIEF** ⑤

**① FORWARD HAND RELAXED AND ELBOW CLOSE TO THE WEAPON (PROVIDING VERTICAL BONE SUPPORT)**

**③ HIGH FIRM PISTOL GRIP**

**⑥ BREATHING**

**⑦ MUSCULAR CONTROL**

**④ PLACEMENT OF REAR ELBOW**

<b>Natural Point of Aim</b>	Natural point of aim is the point at which the rifle sights settle when bone support and muscular relaxation are achieved. The marksman will always check it (and adjust as necessary) every time a position is built.
-----------------------------	--

⑥

# 7 COMMON FACTORS OF SHOOTING POSITIONS

**BUTT OF WEAPON HIGH IN POCKET OF SHOULDER** ②

**STOCKWELD AND EYE RELIEF** ⑤

**① FORWARD HAND RELAXED AND ELBOW CLOSE TO THE WEAPON (PROVIDING VERTICAL BONE SUPPORT)**

**③ HIGH FIRM PISTOL GRIP**

**⑥ BREATHING**

**⑦ MUSCULAR CONTROL**

**④ PLACEMENT OF REAR ELBOW**

<b>Natural Point of Aim</b>	Natural point of aim is the point at which the rifle sights settle when bone support and muscular relaxation are achieved. The marksman will always check it (and adjust as necessary) every time a position is built.
-----------------------------	--

⑥



# AIMING

## CORRECT SIGHT ALIGNMENT

FULL FIELD OF VIEW. The aiming eye aligned to the ocular lens so that no scope shadow is present. Proper stockweld and eye relief are the means for achieving correct sight alignment.

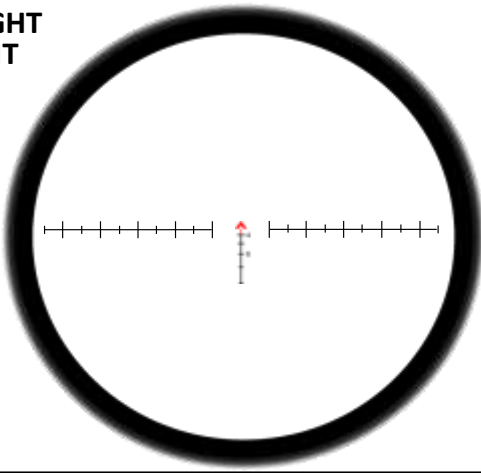

## CORRECT SIGHT PICTURE (100 yd)

The full field of view while maintaining the desired aiming point (reticle) and hold (placement of aiming point on the target). NOTE: Optic outline removed for clarity.

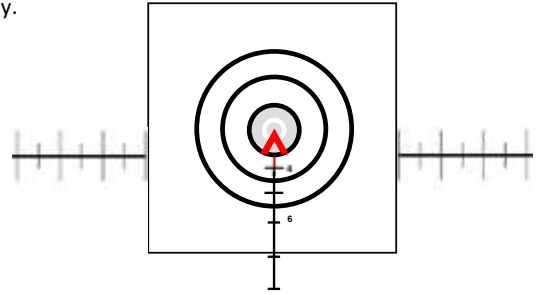

Improper eye relief and/or improper sight alignment will cause scope shadow and will result in improper shot placement.

IMPROPER EYE RELIEF



IMPROPER SIGHT ALIGNMENT

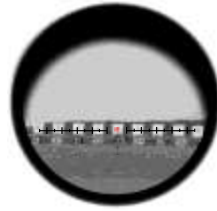

BULLET WILL STRIKE RIGHT

BULLET WILL STRIKE LEFT

BULLET WILL STRIKE LOW

BULLET WILL STRIKE HIGH

7

# AIMING

## CORRECT SIGHT ALIGNMENT

FULL FIELD OF VIEW. The aiming eye aligned to the ocular lens so that no scope shadow is present. Proper stockweld and eye relief are the means for achieving correct sight alignment.

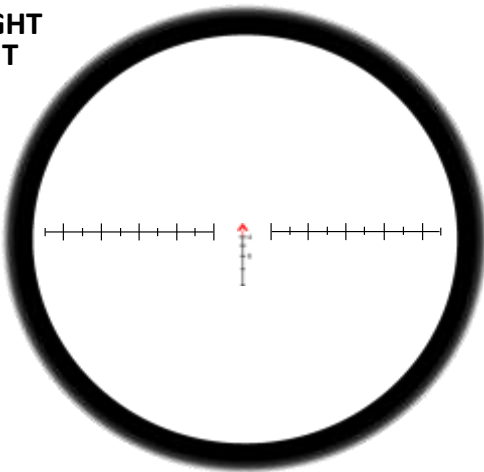

## CORRECT SIGHT PICTURE (100 yd)

The full field of view while maintaining the desired aiming point (reticle) and hold (placement of aiming point on the target). NOTE: Optic outline removed for clarity.

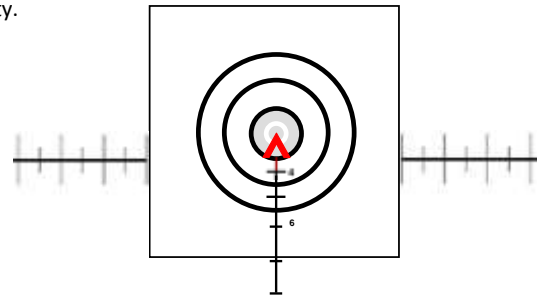

Improper eye relief and/or improper sight alignment will cause scope shadow and will result in improper shot placement.

IMPROPER EYE RELIEF



IMPROPER SIGHT ALIGNMENT



BULLET WILL STRIKE RIGHT

BULLET WILL STRIKE LEFT

BULLET WILL STRIKE LOW

BULLET WILL STRIKE HIGH

7

# BREATH CONTROL

Breathing causes the body to move, which is transferred to the rifle, making it impossible to maintain sight picture. Therefore, natural point of aim, aiming refinement and shot delivery must each be accomplished during the natural respiratory pause - between breaths.

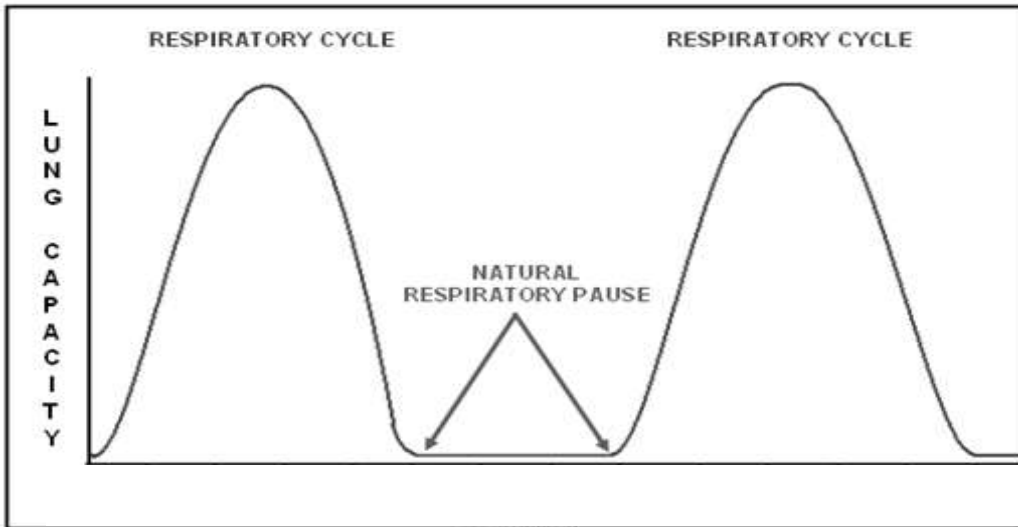

# BREATH CONTROL

Breathing causes the body to move, which is transferred to the rifle, making it impossible to maintain sight picture. Therefore, natural point of aim, aiming refinement and shot delivery must each be accomplished during the natural respiratory pause - between breaths.

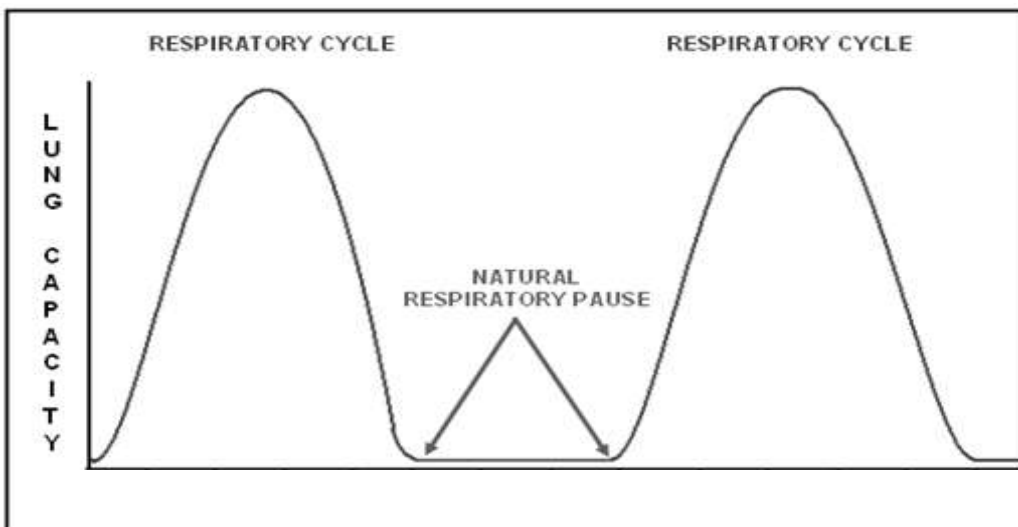

# TRIGGER CONTROL

<b>TRIGGER CONTROL</b>	Trigger Control is the skillful manipulation of the trigger to the rear that causes the rifle to fire without disturbing sight alignment or sight picture.
<b>UNINTERRUPTED TRIGGER CONTROL</b>	Uninterrupted trigger control is when the trigger is moved straight to the rear with a single, smooth motion.
<b>INTERRUPTED TRIGGER CONTROL</b>	Interrupted trigger control is when the application of trigger pressure is interrupted when an error in the aiming process is detected. The applied pressure is kept on the trigger until the error is corrected.

<b>Common Errors</b>	<ul style="list-style-type: none"><li>•Lateral movement of the trigger (not straight to the rear)</li><li>•Grip pressure: trigger finger not moving independently from the hand and other fingers</li></ul>
----------------------	---

# TRIGGER CONTROL

<b>TRIGGER CONTROL</b>	Trigger Control is the skillful manipulation of the trigger to the rear that causes the rifle to fire without disturbing sight alignment or sight picture.
<b>UNINTERRUPTED TRIGGER CONTROL</b>	Uninterrupted trigger control is when the trigger is moved straight to the rear with a single, smooth motion.
<b>INTERRUPTED TRIGGER CONTROL</b>	Interrupted trigger control is when the application of trigger pressure is interrupted when an error in the aiming process is detected. The applied pressure is kept on the trigger until the error is corrected.

<b>Common Errors</b>	<ul style="list-style-type: none"><li>•Lateral movement of the trigger (not straight to the rear)</li><li>•Grip pressure: trigger finger not moving independently from the hand and other fingers</li></ul>
----------------------	---

# FOLLOW-THROUGH / RECOIL RECOVERY

As a shot is fired, the natural recoil of a weapon will test a shooter's position. If proper bone support, muscular control, and natural point of aim are applied, the weapon will return to the shooter's natural point of aim, ready for another shot.

**FOLLOW-THROUGH** - Follow-through is the continued application of the fundamentals until the round has exited the barrel. In combat, follow-through is important to avoid altering the impact of the round by keeping the rifle as still as possible until the round exits the barrel.

**RECOIL RECOVERY** - Management of recoil in preparation to deliver a follow-on shot. Pressure on the trigger is released smoothly until you hear and feel the trigger reset with a "clunk". The finger remains on the trigger to provide consistency in trigger control while firing successive shots.

<b>Common Errors</b>	<ul style="list-style-type: none"><li>•Trigger Control: removing the finger from the trigger</li><li>•Anticipation – bucking, flinching</li><li>•Position – natural point of aim not achieved, forward elbow not providing vertical support</li></ul>
----------------------	---



# FOLLOW-THROUGH / RECOIL RECOVERY

As a shot is fired, the natural recoil of a weapon will test a shooter's position. If proper bone support, muscular control, and natural point of aim are applied, the weapon will return to the shooter's natural point of aim, ready for another shot.

**FOLLOW-THROUGH** - Follow-through is the continued application of the fundamentals until the round has exited the barrel. In combat, follow-through is important to avoid altering the impact of the round by keeping the rifle as still as possible until the round exits the barrel.

**RECOIL RECOVERY** - Management of recoil in preparation to deliver a follow-on shot. Pressure on the trigger is released smoothly until you hear and feel the trigger reset with a "clunk". The finger remains on the trigger to provide consistency in trigger control while firing successive shots.

<b>Common Errors</b>	<ul style="list-style-type: none"><li>•Trigger Control: removing the finger from the trigger</li><li>•Anticipation – bucking, flinching</li><li>•Position – natural point of aim not achieved, forward elbow not providing vertical support</li></ul>
----------------------	---

# WIND

CLASSIFICATION	
<b>DIRECTION</b>	Determine wind direction by observing the direction vegetation is moving, by feeling the wind blow against the body, or by observing the direction of a flag.
<b>VALUE</b>	Winds are classified according to the direction from which they are blowing in relation to the direction of fire. The clock system indicates wind direction and value. The target is always at 12 o'clock.

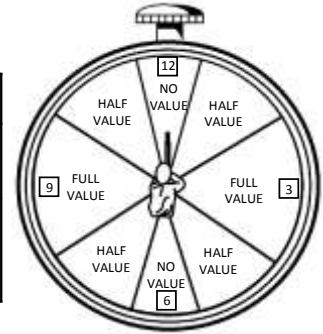

VELOCITY (OBSERVATION METHOD)	
<b>Under 3 MPH</b>	The wind can hardly be felt on the face, but the presence of a slight wind can be detected by drifting smoke.
<b>3 – 5 MPH</b>	Wind can be felt lightly on the face.
<b>5 – 8 MPH</b>	Wind keeps tree leaves in constant motion.
<b>8 – 12 MPH</b>	Wind will raise dust and loose paper.
<b>12 – 15 MPH</b>	Wind will cause small trees to sway.
<b>15 – 25 MPH</b>	Wind will cause large trees to sway.



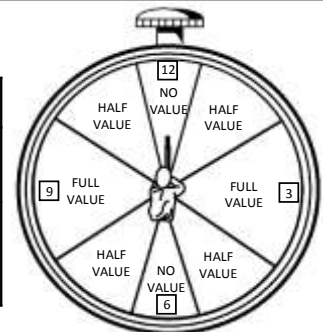

# WIND

CLASSIFICATION	
<b>DIRECTION</b>	Determine wind direction by observing the direction vegetation is moving, by feeling the wind blow against the body, or by observing the direction of a flag.
<b>VALUE</b>	Winds are classified according to the direction from which they are blowing in relation to the direction of fire. The clock system indicates wind direction and value. The target is always at 12 o'clock.







VELOCITY (OBSERVATION METHOD)	
<b>Under 3 MPH</b>	The wind can hardly be felt on the face, but the presence of a slight wind can be detected by drifting smoke.
<b>3 – 5 MPH</b>	Wind can be felt lightly on the face.
<b>5 – 8 MPH</b>	Wind keeps tree leaves in constant motion.
<b>8 – 12 MPH</b>	Wind will raise dust and loose paper.
<b>12 – 15 MPH</b>	Wind will cause small trees to sway.
<b>15 – 25 MPH</b>	Wind will cause large trees to sway.

## WINDAGE HOLDS M16A4

<p>Wind speed is determined by the angle of the flag. The different speeds at each angle can be approximated based on how fast the flag flutters at each angle.</p>										
	5 MPH		10 MPH		15 MPH		20 MPH		25 MPH	
	WIND VALUE		WIND VALUE		WIND VALUE		WIND VALUE		WIND VALUE	
<b>RANGE (yards)</b>	<b>FULL</b>	<b>HALF</b>	<b>FULL</b>	<b>HALF</b>	<b>FULL</b>	<b>HALF</b>	<b>FULL</b>	<b>HALF</b>	<b>FULL</b>	<b>HALF</b>
200	2"	1"	5"	2"	7"	3"	9"	4"	11"	5"
300	5"	2"	11"	5"	16"	8"	22"	11"	27"	13"
500	17"	8"	35"	17"	52"	26"	69"	34"	87"	43"





The values in the above table reflect the windage holds that should be used when the surrounding terrain does not reduce the effect wind has on the flight of the bullet. While conducting marksmanship training on known-distance ranges, these values must be adjusted in order to compensate for the wind-reducing effects of the side-berms and/or trees. The figures in the following pages have been adjusted accordingly.

## WINDAGE HOLDS M16A4

<p>Wind speed is determined by the angle of the flag. The different speeds at each angle can be approximated based on how fast the flag flutters at each angle.</p>										
	5 MPH		10 MPH		15 MPH		20 MPH		25 MPH	
	WIND VALUE		WIND VALUE		WIND VALUE		WIND VALUE		WIND VALUE	
<b>RANGE (yards)</b>	<b>FULL</b>	<b>HALF</b>	<b>FULL</b>	<b>HALF</b>	<b>FULL</b>	<b>HALF</b>	<b>FULL</b>	<b>HALF</b>	<b>FULL</b>	<b>HALF</b>
200	2"	1"	5"	2"	7"	3"	9"	5"	11"	5"
300	5"	2"	11"	5"	16"	8"	22"	11"	26"	13"
500	17"	8"	35"	17"	52"	26"	69"	34"	86"	43"





The values in the above table reflect the windage holds that should be used when the surrounding terrain does not reduce the effect wind has on the flight of the bullet. While conducting marksmanship training on known-distance ranges, these values must be adjusted in order to compensate for the wind-reducing effects of the side-berms and/or trees. The figures in the following pages have been adjusted accordingly.

## WINDAGE HOLDS M4

<p>Wind speed is determined by the angle of the flag. The different speeds at each angle can be approximated based on how fast the flag flutters at each angle.</p>										
	5 MPH		10 MPH		15 MPH		20 MPH		25 MPH	
	WIND VALUE		WIND VALUE		WIND VALUE		WIND VALUE		WIND VALUE	
RANGE (yards)	FULL	HALF	FULL	HALF	FULL	HALF	FULL	HALF	FULL	HALF
200	3"	1"	5"	2"	8"	4"	10"	5"	19"	9"
300	6"	3"	13"	6"	18"	9"	25"	12"	32"	16"
500	20"	10"	40"	20"	60"	30"	81"	40"	101"	50"

The values in the above table reflect the windage holds that should be used when the surrounding terrain does not reduce the effect wind has on the flight of the bullet. While conducting marksmanship training on known-distance ranges, these values must be adjusted in order to compensate for the wind-reducing effects of the side-berms and/or trees. The figures in the following pages have been adjusted accordingly.

## WINDAGE HOLDS M4

<p>Wind speed is determined by the angle of the flag. The different speeds at each angle can be approximated based on how fast the flag flutters at each angle.</p>										
	5 MPH		10 MPH		15 MPH		20 MPH		25 MPH	
	WIND VALUE		WIND VALUE		WIND VALUE		WIND VALUE		WIND VALUE	
RANGE (yards)	FULL	HALF	FULL	HALF	FULL	HALF	FULL	HALF	FULL	HALF
200	3"	1"	5"	2"	8"	4"	10"	5"	19"	9"
300	6"	3"	13"	6"	18"	9"	25"	12"	32"	16"
500	20"	10"	40"	20"	60"	30"	81"	40"	101"	50"

The values in the above table reflect the windage holds that should be used when the surrounding terrain does not reduce the effect wind has on the flight of the bullet. While conducting marksmanship training on known-distance ranges, these values must be adjusted in order to compensate for the wind-reducing effects of the side-berms and/or trees. The figures in the following pages have been adjusted accordingly.

# RCO NOMENCLATURE (RETICLE)

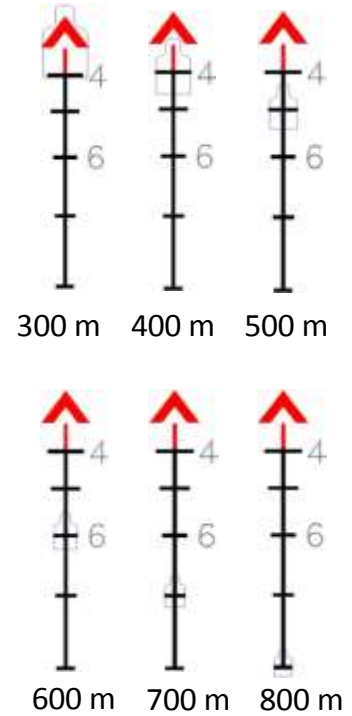
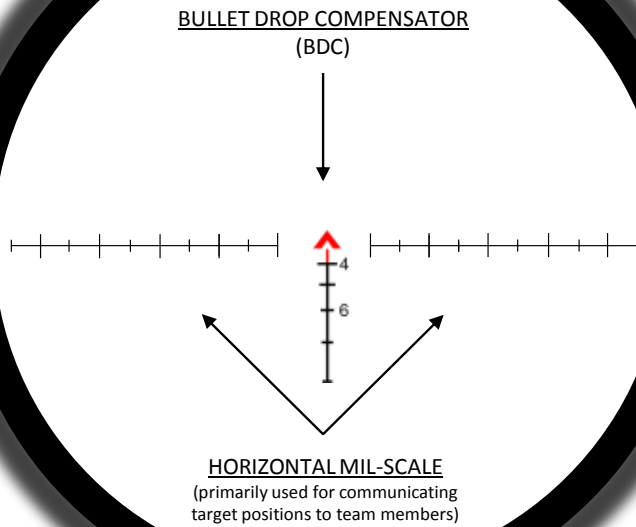

The base of the red chevron and the horizontal stadia lines represent 19" at the indicated ranges (19" is the average width of a man's shoulders).

# RCO NOMENCLATURE (RETICLE)

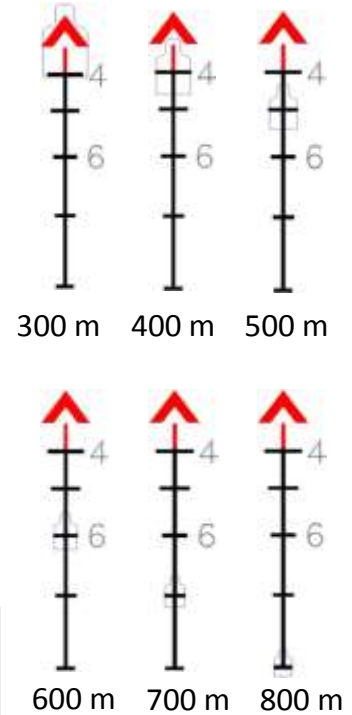
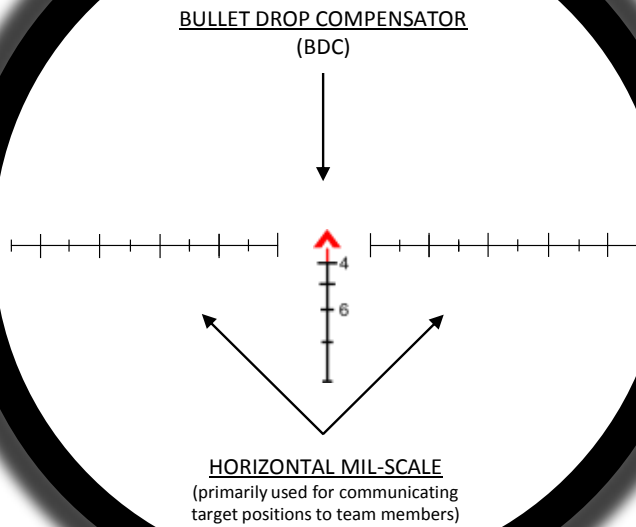

The base of the red chevron and the horizontal stadia lines represent 19" at the indicated ranges (19" is the average width of a man's shoulders).



## DEFINITIONS

<b>AIMING POINT</b>	The precise point where the tip of the front sight post or rifle combat optic reticle pattern is placed in relationship to target.
<b>ZERO (RCO)</b>	Elevation and windage settings required to place a single shot or the center of a shot group in a predesignated location on a target 100 meters/yards, from a specific firing position, under ideal weather conditions.
<b>HOLD (RCO)</b>	The placement of the aiming point relative to the target required to place a single shot, or the center of a shot group, in a predesignated location on a target at a specific range, from a specific firing position, under specific weather conditions
<b>ZERO (BUIS)</b>	Elevation and windate settings required to place a single shot or the center of a shot group in a predesignated location on a target at a specific range, from a specific firing position, under specific weather conditions.
<b>TRUE ZERO (BUIS)</b>	The elevation and windage settings that are required to place a single shot or the center of a shot group, in a predesignated location on a target at a specific range, from a specific firing position, under ideal weather conditions.

## DEFINITIONS

<b>AIMING POINT</b>	The precise point where the tip of the front sight post or rifle combat optic reticle pattern is placed in relationship to target.
<b>ZERO (RCO)</b>	Elevation and windage settings required to place a single shot or the center of a shot group in a predesignated location on a target 100 meters/yards, from a specific firing position, under ideal weather conditions.
<b>HOLD (RCO)</b>	The placement of the aiming point relative to the target required to place a single shot, or the center of a shot group, in a predesignated location on a target at a specific range, from a specific firing position, under specific weather conditions
<b>ZERO (BUIS)</b>	Elevation and windate settings required to place a single shot or the center of a shot group in a predesignated location on a target at a specific range, from a specific firing position, under specific weather conditions.
<b>TRUE ZERO (BUIS)</b>	The elevation and windage settings that are required to place a single shot or the center of a shot group, in a predesignated location on a target at a specific range, from a specific firing position, under ideal weather conditions.

## RCO NOMENCLATURE (EXTERNAL)

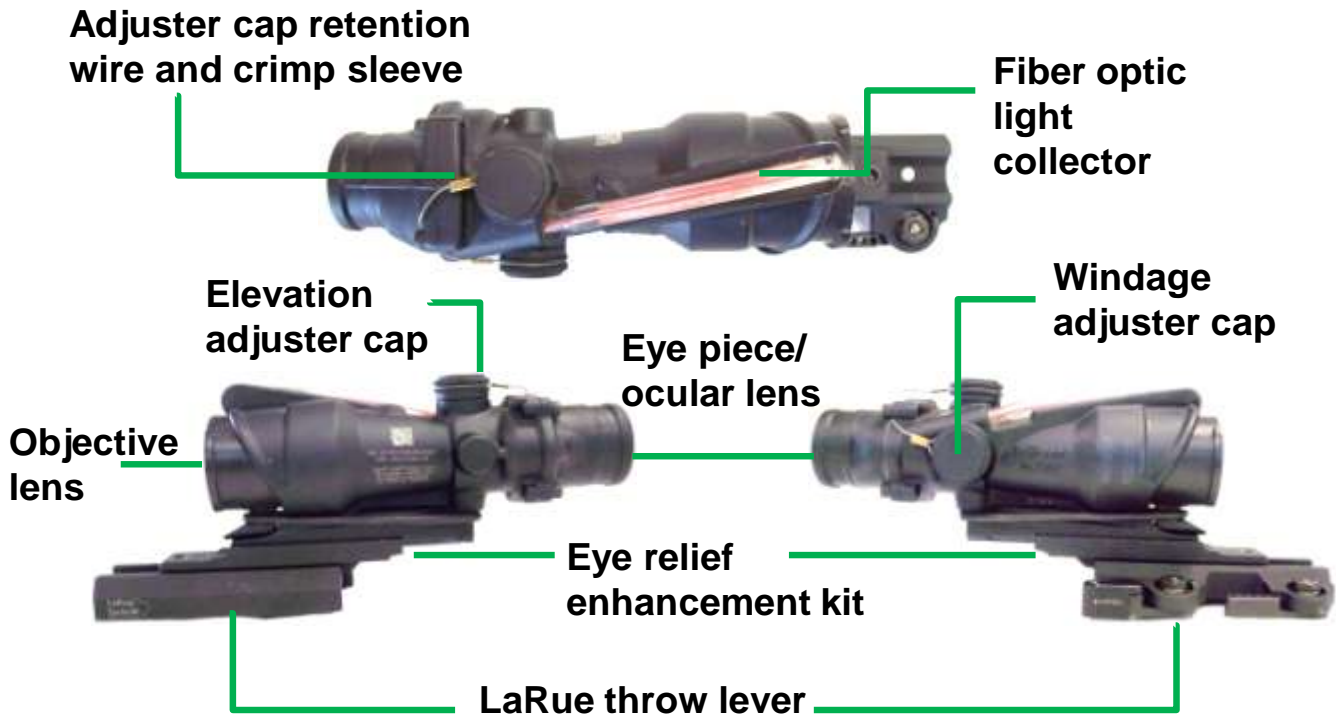

16

## RCO NOMENCLATURE (EXTERNAL)

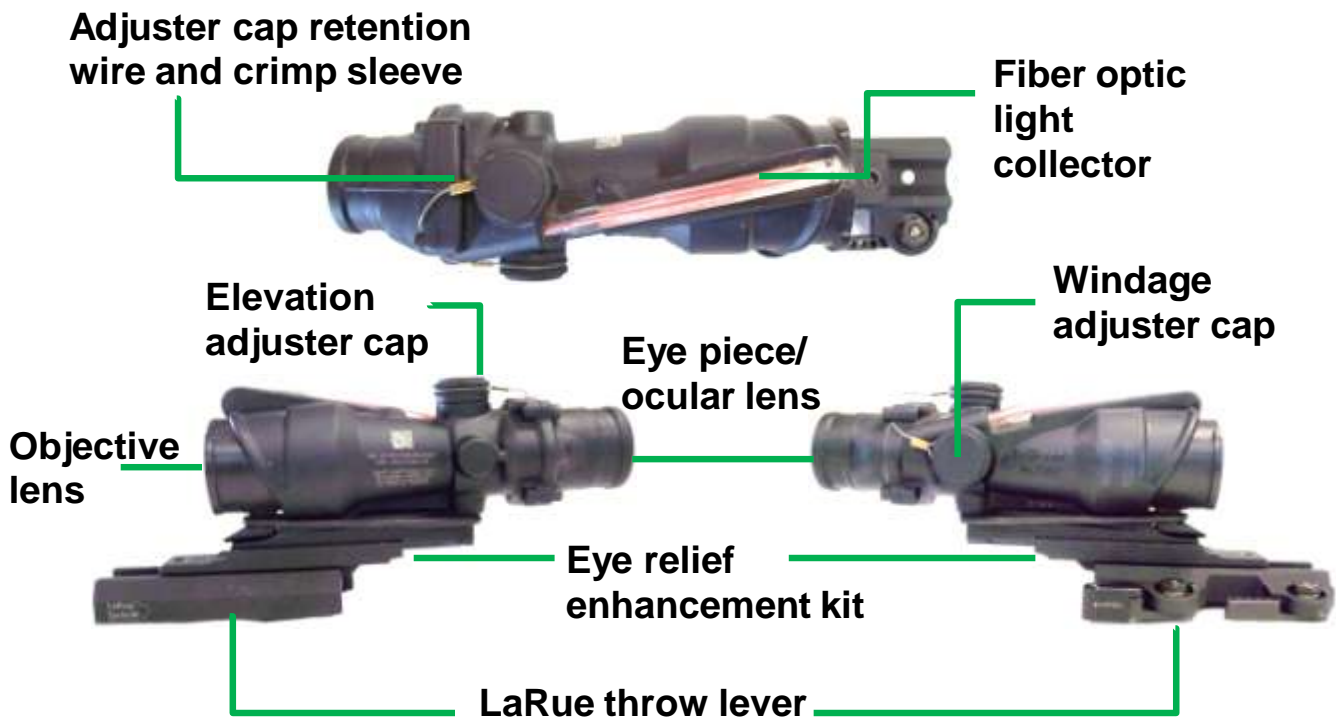

16

## MOUNTING THE RCO (RAIL)

1. Prior to attempting to mount the optic, open the throw levers. Throw levers should be on the right side of the mount.
2. Place the TA31RCO onto the flattop receiver rail. Be sure to align the interface stubs located on the bottom of the adapter with the grooves on the rail of the flattop receiver.
3. The TA31RCO can be placed in any of the slots on top of the receiver to allow for proper eye relief adjustment. Once the ideal position has been determined, apply forward pressure on the optic and move the throw levers into the locked position (move the levers back toward the stock).



17

## MOUNTING THE RCO (RAIL)

1. Prior to attempting to mount the optic, open the throw levers. Throw levers should be on the right side of the mount.
2. Place the TA31RCO onto the flattop receiver rail. Be sure to align the interface stubs located on the bottom of the adapter with the grooves on the rail of the flattop receiver.
3. The TA31RCO can be placed in any of the slots on top of the receiver to allow for proper eye relief adjustment. Once the ideal position has been determined, apply forward pressure on the optic and move the throw levers into the locked position (move the levers back toward the stock).



17

## TABLE 1A COURSE OF FIRE

BLOCK / DAY	STAGE	RANGE	TIME	AMMO	FILL PLAN # MAGS / # RND S EA.	TARGET	POSITION	SLING	
1 & 2	1	SLOW-FIRE	200	25 MIN	20	4/5	ABLE	SITTING KNEELING STANDING ANY	LOOP LOOP PARADE
	2	RAPID-FIRE	200	60 SEC 60 SEC	20	2/10	DOG	SITTING	LOOP
	3	SLOW-FIRE	300	5 MIN	5	1/5	ABLE	SITTING	LOOP
	4	RAPID-FIRE	300	60 SEC 60 SEC	20	2/10	DOG	STANDING TO PRONE	LOOP
	5	SLOW-FIRE	500	15 MIN	15	1/10	B-MOD.	PRONE	LOOP
3	1	SLOW-FIRE	200	20 MIN	15	3/5	ABLE	SITTING KNEELING STANDING	LOOP LOOP PARADE
	2	RAPID-FIRE	200	60 SEC	10	1/10	DOG	SITTING	LOOP
	3	SLOW-FIRE	300	5 MIN	5	1/5	ABLE	SITTING	LOOP
	4	RAPID-FIRE	300	60 SEC	10	1/10	DOG	STANDING TO PRONE	LOOP
	5	SLOW-FIRE	500	10 MIN	10	1/10	B-MOD.	PRONE	LOOP

18

## TABLE 1A COURSE OF FIRE

BLOCK / DAY	STAGE	RANGE	TIME	AMMO	FILL PLAN # MAGS / # RND S EA.	TARGET	POSITION	SLING	
1 & 2	1	SLOW-FIRE	200	25 MIN	20	4/5	ABLE	SITTING KNEELING STANDING ANY	LOOP LOOP PARADE
	2	RAPID-FIRE	200	60 SEC 60 SEC	20	2/10	DOG	SITTING	LOOP
	3	SLOW-FIRE	300	5 MIN	5	1/5	ABLE	SITTING	LOOP
	4	RAPID-FIRE	300	60 SEC 60 SEC	20	2/10	DOG	STANDING TO PRONE	LOOP
	5	SLOW-FIRE	500	15 MIN	15	1/10	B-MOD.	PRONE	LOOP
3	1	SLOW-FIRE	200	20 MIN	15	3/5	ABLE	SITTING KNEELING STANDING	LOOP LOOP PARADE
	2	RAPID-FIRE	200	60 SEC	10	1/10	DOG	SITTING	LOOP
	3	SLOW-FIRE	300	5 MIN	5	1/5	ABLE	SITTING	LOOP
	4	RAPID-FIRE	300	60 SEC	10	1/10	DOG	STANDING TO PRONE	LOOP
	5	SLOW-FIRE	500	10 MIN	10	1/10	B-MOD.	PRONE	LOOP

18

# TABLE 1 TARGET DIMENSIONS

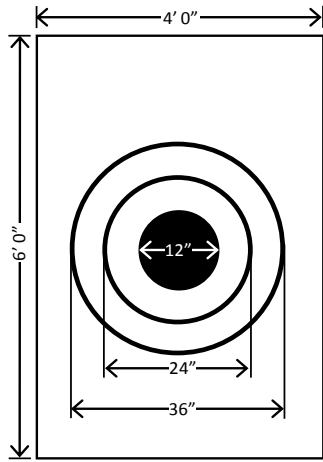

**"Able"  
Target**

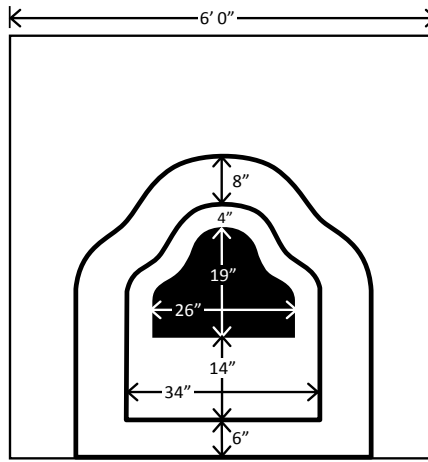

**"Dog"  
Target**

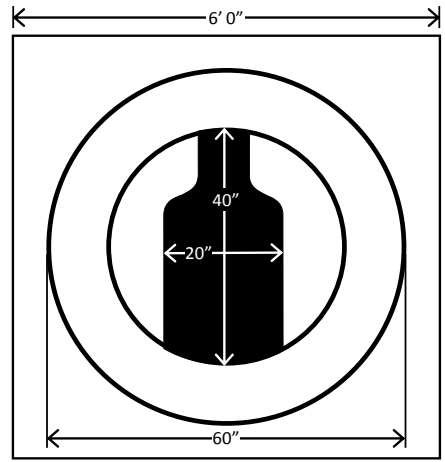

**"B-Modified"  
Target**

# TABLE 1 TARGET DIMENSIONS

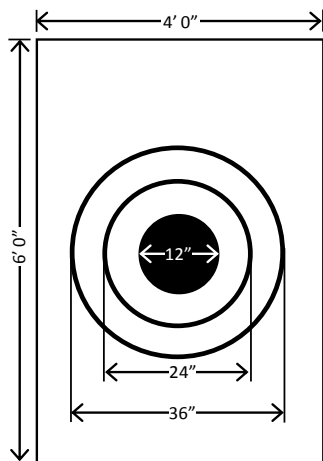



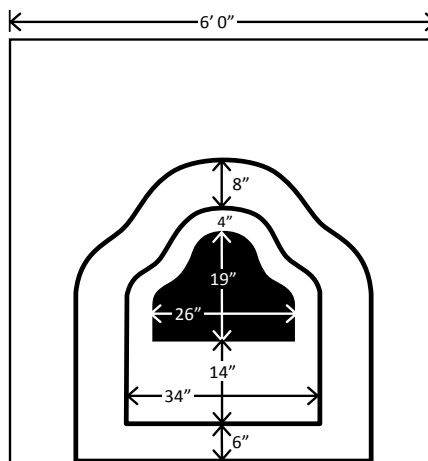



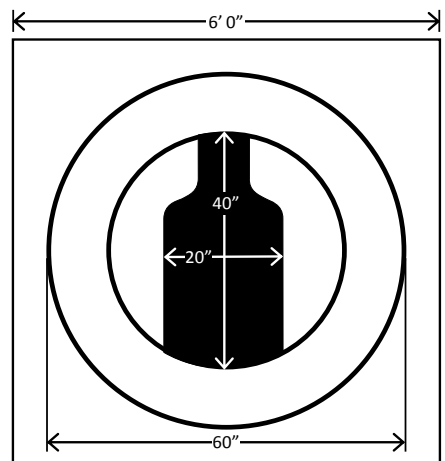

**"Able"  
Target**

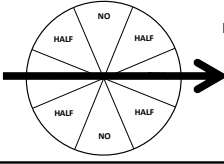

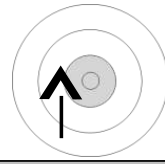
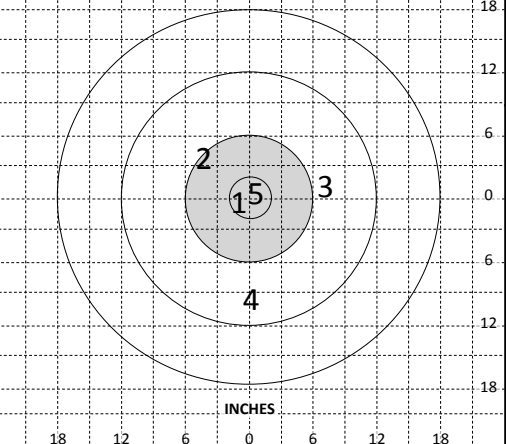

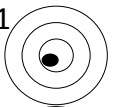
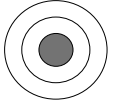
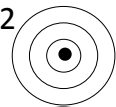
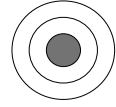
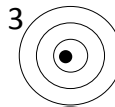

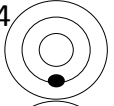
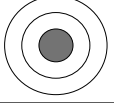
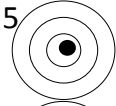
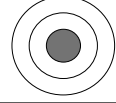
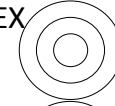



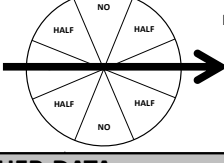

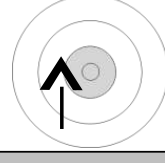
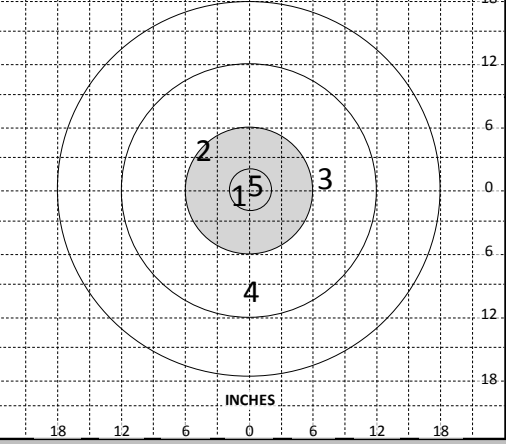

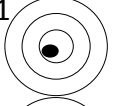
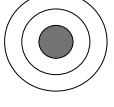
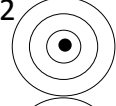
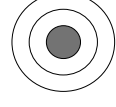
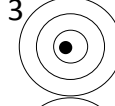

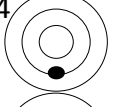
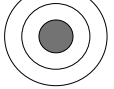
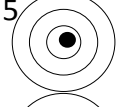
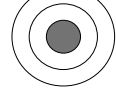
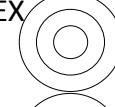
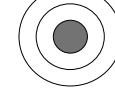
**"Dog"  
Target**









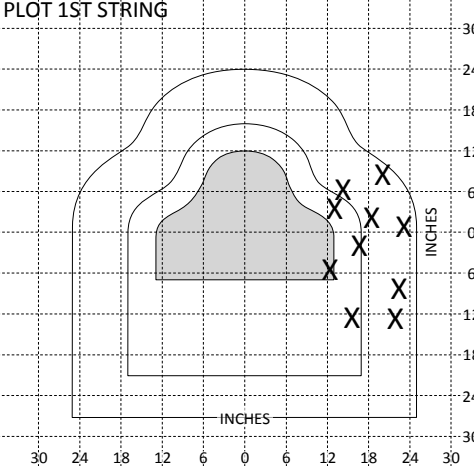
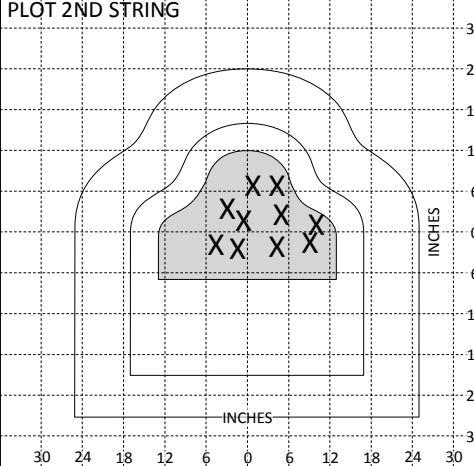

**"B-Modified"  
Target**

200 YARD SLOW-FIRE SITTING		BEFORE FIRING										EXAMPLE			
ZERO		+ WIND =										HOLD			
				HOLDS IN INCHES 											
				5mph		10mph		15mph		20mph		25mph			
				M16A4 M4		M16A4 M4		M16A4 M4		M16A4 M4		M16A4 M4			
				FULL		FULL		FULL		FULL		FULL			
				2		3		5		5		7		8	
				HALF		HALF		HALF		HALF		HALF			
				1		1		2		2		3		4	
				1		1		2		2		3		4	
<b>WEATHER DATA</b>		<b>PLOT</b>										<b>AFTER FIRING</b>			
LIGHT <input type="checkbox"/> OVERCAST <input checked="" type="checkbox"/> PARTLY CLOUDY <input type="checkbox"/> CLEAR		PRECIP <input checked="" type="checkbox"/> DRY <input type="checkbox"/> LT RAIN <input type="checkbox"/> MIST <input type="checkbox"/> HVY RAIN												<b>SIGHT PICTURE ADJUSTMENT (WITHOUT WIND)</b> 	
<b>DURING FIRING</b>		<b>REMARKS</b>													
1 CALL  HOLD  2 CALL  HOLD  3 CALL  HOLD  4 CALL  HOLD  5 CALL  HOLD  EX  HOLD 		Some clouds, sun out of 2:00 low in the sky, temp cool. Changed hold on shot 3. Anticipated shot 4. Otherwise good zero.													

200 YARD SLOW-FIRE SITTING		BEFORE FIRING										EXAMPLE			
ZERO		+ WIND =										HOLD			
				HOLDS IN INCHES 											
				5mph		10mph		15mph		20mph		25mph			
				M16A4 M4		M16A4 M4		M16A4 M4		M16A4 M4		M16A4 M4			
				FULL		FULL		FULL		FULL		FULL			
				2		3		5		5		7		8	
				HALF		HALF		HALF		HALF		HALF			
				1		1		2		2		3		4	
				1		1		2		2		3		4	
<b>WEATHER DATA</b>		<b>PLOT</b>										<b>AFTER FIRING</b>			
LIGHT <input type="checkbox"/> OVERCAST <input checked="" type="checkbox"/> PARTLY CLOUDY <input type="checkbox"/> CLEAR		PRECIP <input checked="" type="checkbox"/> DRY <input type="checkbox"/> LT RAIN <input type="checkbox"/> MIST <input type="checkbox"/> HVY RAIN												<b>SIGHT PICTURE ADJUSTMENT (WITHOUT WIND)</b> 	
<b>DURING FIRING</b>		<b>REMARKS</b>													
1 CALL  HOLD  2 CALL  HOLD  3 CALL  HOLD  4 CALL  HOLD  5 CALL  HOLD  EX  HOLD 		Some clouds, sun out of 2:00 low in the sky, temp cool. Changed hold on shot 3. Anticipated shot 4. Otherwise good zero.													

200 YARD RAPID-FIRE SITTING			BEFORE FIRING			EXAMPLE																																																
ZERO	+	WIND	=				HOLD																																															
		HOLDS IN INCHES																																																				
		<table border="1" style="font-size: small;"> <thead> <tr> <th>VALUE</th> <th colspan="2">5mph</th> <th colspan="2">10mph</th> <th colspan="2">15mph</th> <th colspan="2">20mph</th> <th colspan="2">25mph</th> </tr> <tr> <td></td> <th>M16A4</th> <th>M4</th> <th>M16A4</th> <th>M4</th> <th>M16A4</th> <th>M4</th> <th>M16A4</th> <th>M4</th> <th>M16A4</th> <th>M4</th> </tr> </thead> <tbody> <tr> <td>FULL</td> <td>2</td> <td>3</td> <td>5</td> <td>5</td> <td>7</td> <td>8</td> <td>9</td> <td>10</td> <td>11</td> <td>19</td> </tr> <tr> <td>HALF</td> <td>1</td> <td>1</td> <td>2</td> <td>2</td> <td>3</td> <td>4</td> <td>4</td> <td>5</td> <td>5</td> <td>9</td> </tr> </tbody> </table>	VALUE	5mph		10mph		15mph		20mph		25mph			M16A4	M4	M16A4	M4	M16A4	M4	M16A4	M4	M16A4	M4	FULL	2	3	5	5	7	8	9	10	11	19	HALF	1	1	2	2	3	4	4	5	5	9								
VALUE	5mph		10mph		15mph		20mph		25mph																																													
	M16A4	M4	M16A4	M4	M16A4	M4	M16A4	M4	M16A4	M4																																												
FULL	2	3	5	5	7	8	9	10	11	19																																												
HALF	1	1	2	2	3	4	4	5	5	9																																												
PLOT 1ST STRING	DURING FIRING			PLOT 2ND STRING																																																		
	2ND STRING HOLD																																																					
			REMARKS																																																			
<p>LIGHT</p> <input checked="" type="checkbox"/> OVERCAST <input type="checkbox"/> PARTLY CLOUDY <input type="checkbox"/> CLEAR			<p>PRECIP</p> <input type="checkbox"/> DRY <input type="checkbox"/> LT RAIN <input checked="" type="checkbox"/> MIST <input type="checkbox"/> HVY RAIN			<p>Miscalculated wind data. Corrected on 2<sup>nd</sup> string.</p>			<p>SIGHT PICTURE ADJUSTMENT (WITHOUT WIND)</p>																																													

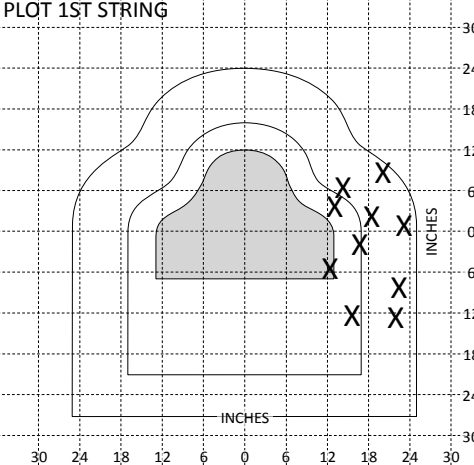
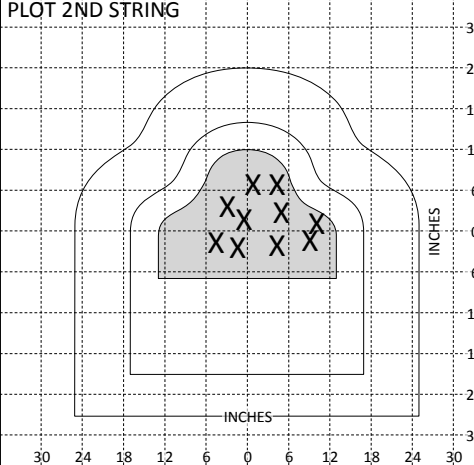
200 YARD RAPID-FIRE SITTING			BEFORE FIRING			EXAMPLE																																																
ZERO	+	WIND	=				HOLD																																															
		HOLDS IN INCHES																																																				
		<table border="1" style="font-size: small;"> <thead> <tr> <th>VALUE</th> <th colspan="2">5mph</th> <th colspan="2">10mph</th> <th colspan="2">15mph</th> <th colspan="2">20mph</th> <th colspan="2">25mph</th> </tr> <tr> <td></td> <th>M16A4</th> <th>M4</th> <th>M16A4</th> <th>M4</th> <th>M16A4</th> <th>M4</th> <th>M16A4</th> <th>M4</th> <th>M16A4</th> <th>M4</th> </tr> </thead> <tbody> <tr> <td>FULL</td> <td>2</td> <td>3</td> <td>5</td> <td>5</td> <td>7</td> <td>8</td> <td>9</td> <td>10</td> <td>11</td> <td>19</td> </tr> <tr> <td>HALF</td> <td>1</td> <td>1</td> <td>2</td> <td>2</td> <td>3</td> <td>4</td> <td>4</td> <td>5</td> <td>5</td> <td>9</td> </tr> </tbody> </table>	VALUE	5mph		10mph		15mph		20mph		25mph			M16A4	M4	M16A4	M4	M16A4	M4	M16A4	M4	M16A4	M4	FULL	2	3	5	5	7	8	9	10	11	19	HALF	1	1	2	2	3	4	4	5	5	9								
VALUE	5mph		10mph		15mph		20mph		25mph																																													
	M16A4	M4	M16A4	M4	M16A4	M4	M16A4	M4	M16A4	M4																																												
FULL	2	3	5	5	7	8	9	10	11	19																																												
HALF	1	1	2	2	3	4	4	5	5	9																																												
PLOT 1ST STRING	DURING FIRING			PLOT 2ND STRING																																																		
	2ND STRING HOLD																																																					
			REMARKS																																																			
<p>LIGHT</p> <input checked="" type="checkbox"/> OVERCAST <input type="checkbox"/> PARTLY CLOUDY <input type="checkbox"/> CLEAR			<p>PRECIP</p> <input type="checkbox"/> DRY <input type="checkbox"/> LT RAIN <input checked="" type="checkbox"/> MIST <input type="checkbox"/> HVY RAIN			<p>Miscalculated wind data. Corrected on 2<sup>nd</sup> string.</p>			<p>SIGHT PICTURE ADJUSTMENT (WITHOUT WIND)</p>																																													

500 YARD SLOW-FIRE PRONE		BEFORE FIRING										EXAMPLE		
ZERO		+ WIND =										HOLD		
	4	HOLDS IN INCHES												
				5mph		10mph		15mph		20mph		25mph		
				M16A4 M4		M16A4 M4		M16A4 M4		M16A4 M4		M16A4 M4		
				FULL		FULL		FULL		FULL		FULL		
				17 20		35 40		52 60		69 81		87 101		
				HALF		HALF		HALF		HALF		HALF		
				8 10		17 20		26 30		34 40		43 50		
WEATHER DATA				PLOT										AFTER FIRING
LIGHT <input checked="" type="checkbox"/> OVERCAST <input type="checkbox"/> PARTLY CLOUDY <input type="checkbox"/> CLEAR 				PRECIP <input type="checkbox"/> DRY <input checked="" type="checkbox"/> LT RAIN <input type="checkbox"/> MIST <input type="checkbox"/> HVY RAIN										SIGHT PICTURE ADJUSTMENT (WITHOUT WIND)
CALL 1 2 3 4 5														
HOLD 6 7 8 9 10														
CALL 11 12 13 14														
HOLD 15 16 17 18 19														
<b>REMARKS</b>														
Jerked the 6th shot. Ocular lens fogging up.														

500 YARD SLOW-FIRE PRONE		BEFORE FIRING										EXAMPLE		
ZERO		+ WIND =										HOLD		
	4	HOLDS IN INCHES												
				5mph		10mph		15mph		20mph		25mph		
				M16A4 M4		M16A4 M4		M16A4 M4		M16A4 M4		M16A4 M4		
				FULL		FULL		FULL		FULL		FULL		
				17 20		35 40		52 60		69 81		87 101		
				HALF		HALF		HALF		HALF		HALF		
				8 10		17 20		26 30		34 40		43 50		
WEATHER DATA				PLOT										AFTER FIRING
LIGHT <input checked="" type="checkbox"/> OVERCAST <input type="checkbox"/> PARTLY CLOUDY <input type="checkbox"/> CLEAR 				PRECIP <input type="checkbox"/> DRY <input checked="" type="checkbox"/> LT RAIN <input type="checkbox"/> MIST <input type="checkbox"/> HVY RAIN										SIGHT PICTURE ADJUSTMENT (WITHOUT WIND)
CALL 1 2 3 4 5														
HOLD 6 7 8 9 10														
CALL 11 12 13 14														
HOLD 15 16 17 18 19														
<b>REMARKS</b>														
Jerked the 6th shot. Ocular lens fogging up.														



200 YARD SLOW-FIRE SITTING		BEFORE FIRING										PRACTICE					
ZERO		+ WIND =										HOLD					
		HOLDS IN INCHES															
		5mph		10mph		15mph		20mph		25mph							
		M16A4	M4	M16A4	M4	M16A4	M4	M16A4	M4	M16A4	M4						
		VALUE															
		FULL	2	3	5	5	7	8	9	10	11	19					
		HALF	1	1	2	2	3	4	4	5	5	9					
WEATHER DATA		PLOT										AFTER FIRING					
LIGHT <input type="checkbox"/> OVERCAST <input type="checkbox"/> PARTLY CLOUDY <input type="checkbox"/> CLEAR 		PRECIP <input type="checkbox"/> DRY <input type="checkbox"/> LT RAIN <input type="checkbox"/> MIST <input type="checkbox"/> HVY RAIN										<b>SIGHT PICTURE ADJUSTMENT (WITHOUT WIND)</b>					
DURING FIRING																	
1													2		3		
CALL																	
HOLD																	
4	5												EX				
CALL																	
HOLD																	
		REMARKS															

200 YARD SLOW-FIRE SITTING		BEFORE FIRING										PRACTICE					
ZERO		+ WIND =										HOLD					
		HOLDS IN INCHES															
		5mph		10mph		15mph		20mph		25mph							
		M16A4	M4	M16A4	M4	M16A4	M4	M16A4	M4	M16A4	M4						
		VALUE															
		FULL	2	3	5	5	7	8	9	10	11	19					
		HALF	1	1	2	2	3	4	4	5	5	9					
WEATHER DATA		PLOT										AFTER FIRING					
LIGHT <input type="checkbox"/> OVERCAST <input type="checkbox"/> PARTLY CLOUDY <input type="checkbox"/> CLEAR 		PRECIP <input type="checkbox"/> DRY <input type="checkbox"/> LT RAIN <input type="checkbox"/> MIST <input type="checkbox"/> HVY RAIN										<b>SIGHT PICTURE ADJUSTMENT (WITHOUT WIND)</b>					
DURING FIRING																	
1													2		3		
CALL																	
HOLD																	
4	5												EX				
CALL																	
HOLD																	
		REMARKS															

200 YARD RAPID-FIRE SITTING			BEFORE FIRING										PRACTICE	
ZERO		+	WIND										=	HOLD
		HOLDS IN INCHES												
		VALUE	5mph		10mph		15mph		20mph		25mph			
			M16A4	M4	M16A4	M4	M16A4	M4	M16A4	M4	M16A4	M4		
		FULL	2	3	5	5	7	8	9	10	11	19		
		HALF	1	1	2	2	3	4	4	5	5	9		
PLOT 1ST STRING			DURING FIRING										PLOT 2ND STRING	
			2ND STRING HOLD											
			REMARKS											
LIGHT <input type="checkbox"/> OVERCAST <input type="checkbox"/> PARTLY CLOUDY <input type="checkbox"/> CLEAR			PRECIP <input type="checkbox"/> DRY <input type="checkbox"/> LT RAIN <input type="checkbox"/> MIST <input type="checkbox"/> HVY RAIN		SIGHT PICTURE ADJUSTMENT (WITHOUT WIND)									

200 YARD RAPID-FIRE SITTING			BEFORE FIRING										PRACTICE	
ZERO		+	WIND										=	HOLD
		HOLDS IN INCHES												
		VALUE	5mph		10mph		15mph		20mph		25mph			
			M16A4	M4	M16A4	M4	M16A4	M4	M16A4	M4	M16A4	M4		
		FULL	2	3	5	5	7	8	9	10	11	19		
		HALF	1	1	2	2	3	4	4	5	5	9		
PLOT 1ST STRING			DURING FIRING										PLOT 2ND STRING	
			2ND STRING HOLD											
			REMARKS											
LIGHT <input type="checkbox"/> OVERCAST <input type="checkbox"/> PARTLY CLOUDY <input type="checkbox"/> CLEAR			PRECIP <input type="checkbox"/> DRY <input type="checkbox"/> LT RAIN <input type="checkbox"/> MIST <input type="checkbox"/> HVY RAIN		SIGHT PICTURE ADJUSTMENT (WITHOUT WIND)									

**500 YARD SLOW-FIRE PRONE**

**BEFORE FIRING**

**PRACTICE**

ZERO

WIND

HOLD

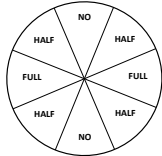
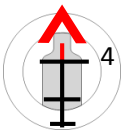

HOLDS IN INCHES



VALUE	5mph		10mph		15mph		20mph		25mph	
	M16A4	M4	M16A4	M4	M16A4	M4	M16A4	M4	M16A4	M4
FULL	17	20	35	40	52	60	69	81	87	101
HALF	8	10	17	20	26	30	34	40	43	50



**WEATHER DATA**

- LIGHT
- OVERCAST
- PARTLY CLOUDY
- CLEAR

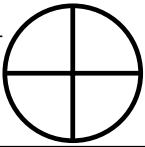

- PRECIP
- DRY  LT RAIN
- MIST  HVY RAIN

**PLOT**

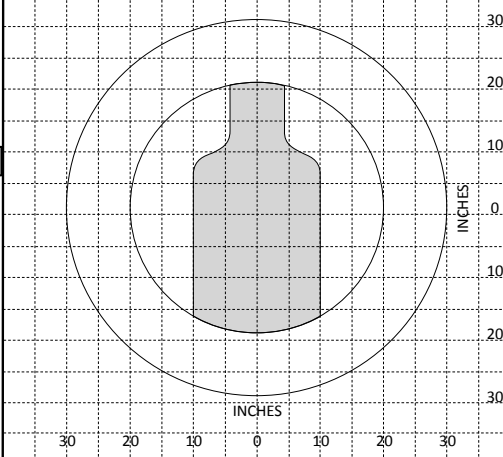

**AFTER FIRING**

**SIGHT PICTURE ADJUSTMENT (WITHOUT WIND)**



	1	2	3	4	5
CALL					
HOLD					
	6	7	8	9	10
CALL					
HOLD					

**REMARKS**

**500 YARD SLOW-FIRE PRONE**

**BEFORE FIRING**

**PRACTICE**

ZERO

WIND

HOLD

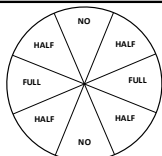
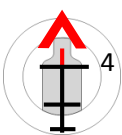

HOLDS IN INCHES



VALUE	5mph		10mph		15mph		20mph		25mph	
	M16A4	M4	M16A4	M4	M16A4	M4	M16A4	M4	M16A4	M4
FULL	17	20	35	40	52	60	69	81	87	101
HALF	8	10	17	20	26	30	34	40	43	50

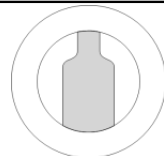

**WEATHER DATA**

- LIGHT
- OVERCAST
- PARTLY CLOUDY
- CLEAR

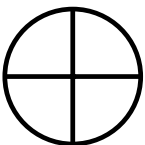

- PRECIP
- DRY  LT RAIN
- MIST  HVY RAIN

**PLOT**

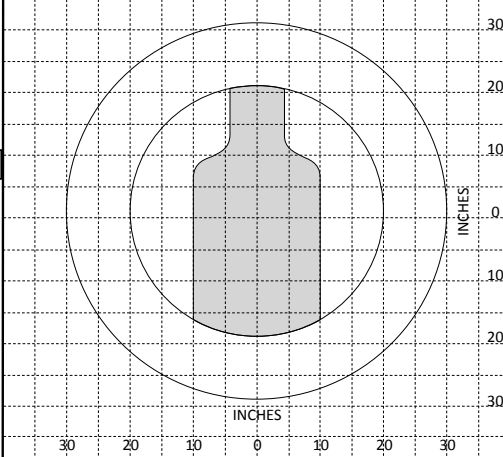

**AFTER FIRING**

**SIGHT PICTURE ADJUSTMENT (WITHOUT WIND)**



	1	2	3	4	5
CALL					
HOLD					
	6	7	8	9	10
CALL					
HOLD					

**REMARKS**

# 36 YD PRE-ZERO SIGHT SETTING

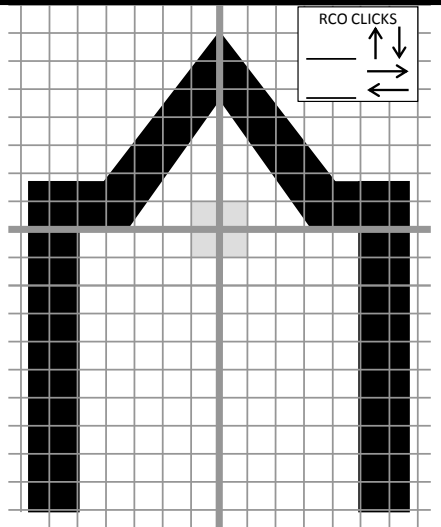
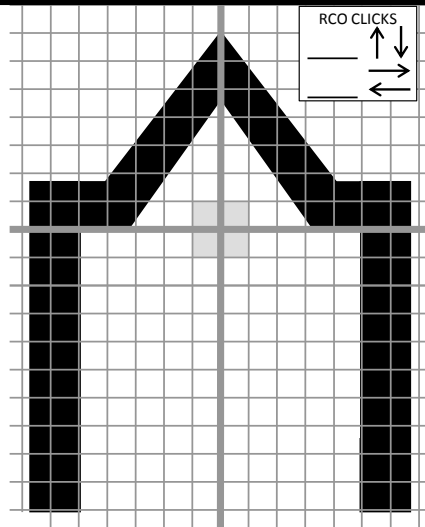
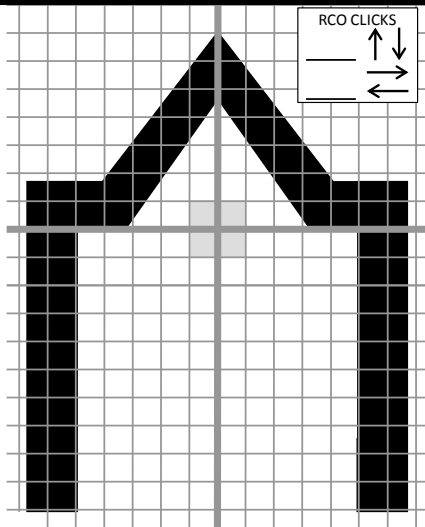

Two major objectives for the exercise:

1. To determine if the weapon can hold a group or is mechanically deficient.
2. To determine if the shooter can apply marksmanship fundamentals.

The steps for grouping are:

1. The shooter fires five rounds at the center target.
2. The coach measures the size of the group to determine if the shooter can hold a nine minute of angle group. The shooter fires the next five rounds on the left target.
3. Repeat step two. The shooter fires the last five rounds on the right target.
4. Repeat step two. If the weapon holds a nine minute of angle group the shooter is done firing. If not, range personnel will fire the weapon. If the weapon does not hold a group, issue the shooter a new weapon and repeat the exercise.

Each square = 1/2 inch

ELEVATION:

RCO - 9 clicks = 1 in

M16A4 (BUIS) - 1 click = 1/2 in

WINDAGE:

RCO - 9 clicks = 1 in

M16A4 - (BUIS) - 3 clicks = 1/2 in

26

# 36 YD PRE-ZERO SIGHT SETTING

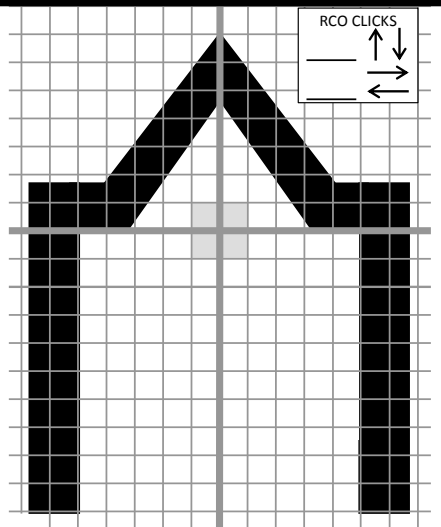
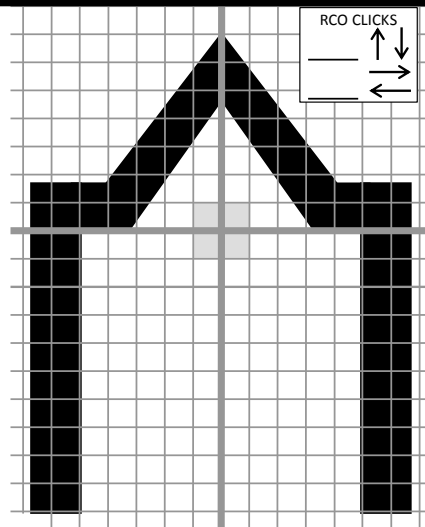
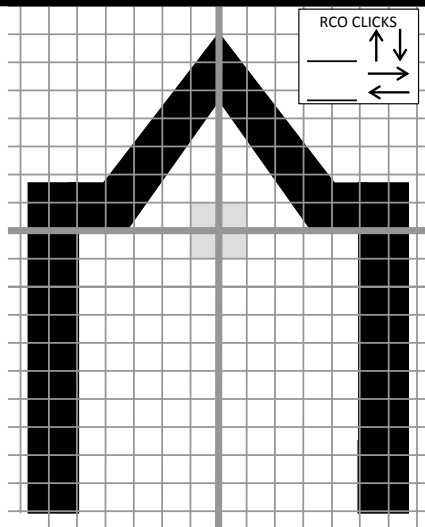

Two major objectives for the exercise:

1. To determine if the weapon can hold a group or is mechanically deficient.
2. To determine if the shooter can apply marksmanship fundamentals.

The steps for grouping are:

1. The shooter fires five rounds at the center target.
2. The coach measures the size of the group to determine if the shooter can hold a nine minute of angle group. The shooter fires the next five rounds on the left target.
3. Repeat step two. The shooter fires the last five rounds on the right target.
4. Repeat step two. If the weapon holds a nine minute of angle group the shooter is done firing. If not, range personnel will fire the weapon. If the weapon does not hold a group, issue the shooter a new weapon and repeat the exercise.

Each square = 1/2 inch

ELEVATION:

RCO - 9 clicks = 1 in

M16A4 (BUIS) - 1 click = 1/2 in

WINDAGE:

RCO - 9 clicks = 1 in

M16A4 - (BUIS) - 3 clicks = 1/2 in

26

**100 YARD ZERO** **BEFORE FIRING** **TABLE 1**

**ZERO** **+** **WIND** **=** **HOLD**

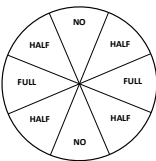
HOLDS IN INCHES



VALUE	5mph M16A4 M4		10mph M16A4 M4		15mph M16A4 M4		20mph M16A4 M4		25mph M16A4 M4	
FULL	1	--	1	1	2	2	2	2	3	3
HALF	½	--	½	½	1	1	1	1	1½	1½



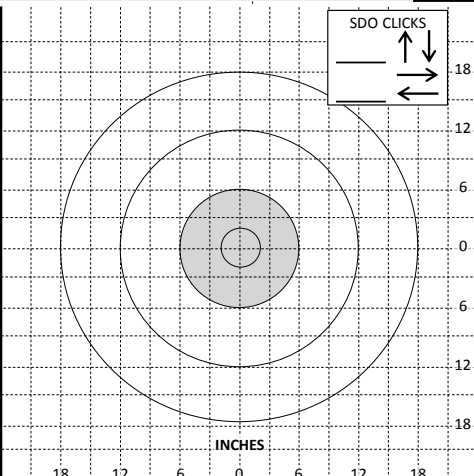
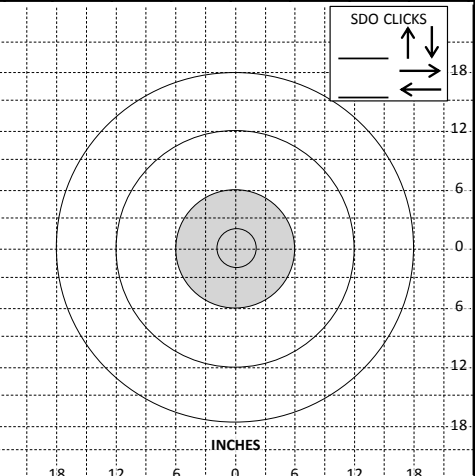
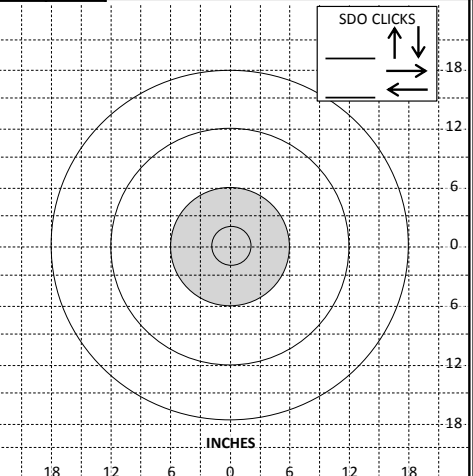



**LIGHT**

OVERCAST

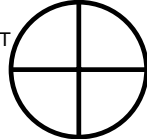
PARTLY CLOUDY

CLEAR



**PRECIP**

DRY

MIST

LT RAIN

HVY RAIN

**SIGHT PICTURE ADJUSTMENT (WITHOUT WIND)**



(27)

**100 YARD ZERO** **BEFORE FIRING** **TABLE 1**

**ZERO** **+** **WIND** **=** **HOLD**

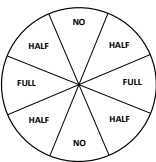
HOLDS IN INCHES



VALUE	5mph M16A4 M4		10mph M16A4 M4		15mph M16A4 M4		20mph M16A4 M4		25mph M16A4 M4	
FULL	1	--	1	1	2	2	2	2	3	3
HALF	½	--	½	½	1	1	1	1	1½	1½



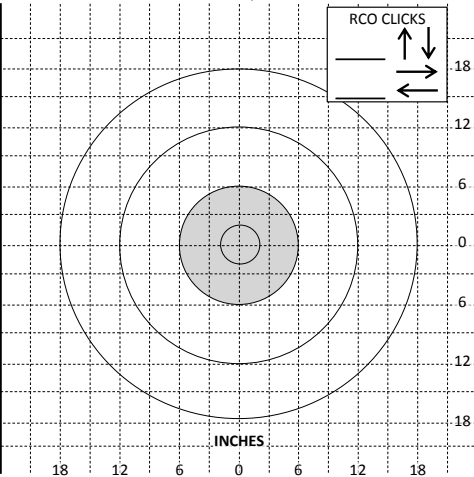
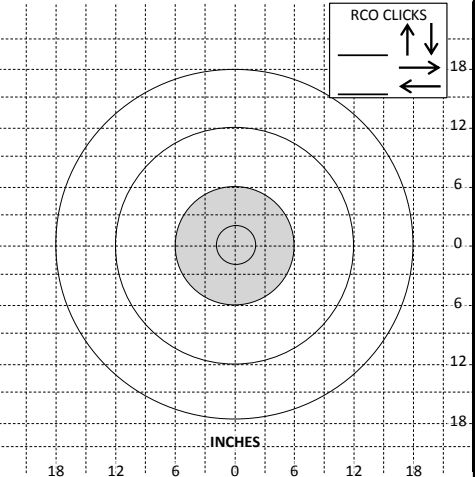
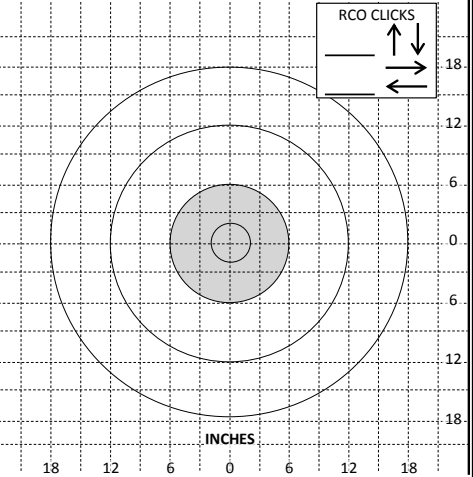



**LIGHT**

OVERCAST

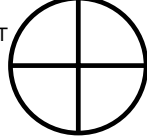
PARTLY CLOUDY

CLEAR



**PRECIP**

DRY

MIST

LT RAIN

HVY RAIN

**SIGHT PICTURE ADJUSTMENT (WITHOUT WIND)**



(27)

**200 YARD SLOW-FIRE SITTING** **BEFORE FIRING** **DAY ONE**

ZERO + WIND = **HOLD**

HOLDS IN INCHES

VALUE	5mph M16A4 M4		10mph M16A4 M4		15mph M16A4 M4		20mph M16A4 M4		25mph M16A4 M4	
FULL	2	3	5	5	7	8	9	10	11	19
HALF	1	1	2	2	3	4	4	5	5	9

---

**WEATHER DATA**

LIGHT

OVERCAST

PARTLY CLOUDY

CLEAR

PRECIP

DRY  LT RAIN

MIST  HVY RAIN

**PLOT**

**AFTER FIRING**

**SIGHT PICTURE ADJUSTMENT (WITHOUT WIND)**

---

**DURING FIRING**

1	2	3
CALL		
HOLD		
4	5	EX
CALL		
HOLD		

**REMARKS**

**200 YARD SLOW-FIRE SITTING** **BEFORE FIRING** **DAY ONE**

ZERO + WIND = **HOLD**

HOLDS IN INCHES

VALUE	5mph M16A4 M4		10mph M16A4 M4		15mph M16A4 M4		20mph M16A4 M4		25mph M16A4 M4	
FULL	2	3	5	5	7	8	9	10	11	19
HALF	1	1	2	2	3	4	4	5	5	9

---

**WEATHER DATA**

LIGHT

OVERCAST

PARTLY CLOUDY

CLEAR

PRECIP

DRY  LT RAIN

MIST  HVY RAIN

**PLOT**

**AFTER FIRING**

**SIGHT PICTURE ADJUSTMENT (WITHOUT WIND)**

---

**DURING FIRING**

1	2	3
CALL		
HOLD		
4	5	EX
CALL		
HOLD		

**REMARKS**

**200 YARD SLOW-FIRE KNEELING** **BEFORE FIRING** **DAY ONE**

ZERO + WIND = **HOLD**

HOLDS IN INCHES

VALUE	5mph		10mph		15mph		20mph		25mph	
	M16A4	M4	M16A4	M4	M16A4	M4	M16A4	M4	M16A4	M4
FULL	2	3	5	5	7	8	9	10	11	19
HALF	1	1	2	2	3	4	4	5	5	9

---

**WEATHER DATA**

LIGHT

OVERCAST

PARTLY CLOUDY

CLEAR

PRECIP

DRY  LT RAIN

MIST  HVY RAIN

**PLOT**

**AFTER FIRING**

**SIGHT PICTURE ADJUSTMENT (WITHOUT WIND)**

---

**DURING FIRING**

	1	2	3
CALL			
HOLD			
	4	5	EX
CALL			
HOLD			

**REMARKS**

**200 YARD SLOW-FIRE KNEELING** **BEFORE FIRING** **DAY ONE**

ZERO + WIND = **HOLD**

HOLDS IN INCHES

VALUE	5mph		10mph		15mph		20mph		25mph	
	M16A4	M4	M16A4	M4	M16A4	M4	M16A4	M4	M16A4	M4
FULL	2	3	5	5	7	8	9	10	11	19
HALF	1	1	2	2	3	4	4	5	5	9

---

**WEATHER DATA**

LIGHT

OVERCAST

PARTLY CLOUDY

CLEAR

PRECIP

DRY  LT RAIN

MIST  HVY RAIN

**PLOT**

**AFTER FIRING**

**SIGHT PICTURE ADJUSTMENT (WITHOUT WIND)**

---

**DURING FIRING**

	1	2	3
CALL			
HOLD			
	4	5	EX
CALL			
HOLD			

**REMARKS**

200 YARD SLOW-FIRE STANDING		BEFORE FIRING										DAY ONE					
ZERO		+ WIND =										HOLD					
		HOLDS IN INCHES															
		VALUE	5mph M16A4 M4		10mph M16A4 M4		15mph M16A4 M4		20mph M16A4 M4		25mph M16A4 M4						
		FULL	2	3	5	5	7	8	9	10	11	19					
		HALF	1	1	2	2	3	4	4	5	5	9					
WEATHER DATA		PLOT										AFTER FIRING					
LIGHT <input type="checkbox"/> OVERCAST <input type="checkbox"/> PARTLY CLOUDY <input type="checkbox"/> CLEAR				PRECIP <input type="checkbox"/> DRY <input type="checkbox"/> LT RAIN <input type="checkbox"/> MIST <input type="checkbox"/> HVY RAIN										<b>SIGHT PICTURE ADJUSTMENT (WITHOUT WIND)</b>			
DURING FIRING																	
1	2													3	EX		
CALL	HOLD													CALL	HOLD	CALL	HOLD
4	5													CALL	HOLD	CALL	HOLD
		REMARKS															

200 YARD SLOW-FIRE STANDING		BEFORE FIRING										DAY ONE					
ZERO		+ WIND =										HOLD					
		HOLDS IN INCHES															
		VALUE	5mph M16A4 M4		10mph M16A4 M4		15mph M16A4 M4		20mph M16A4 M4		25mph M16A4 M4						
		FULL	2	3	5	5	7	8	9	10	11	19					
		HALF	1	1	2	2	3	4	4	5	5	9					
WEATHER DATA		PLOT										AFTER FIRING					
LIGHT <input type="checkbox"/> OVERCAST <input type="checkbox"/> PARTLY CLOUDY <input type="checkbox"/> CLEAR				PRECIP <input type="checkbox"/> DRY <input type="checkbox"/> LT RAIN <input type="checkbox"/> MIST <input type="checkbox"/> HVY RAIN										<b>SIGHT PICTURE ADJUSTMENT (WITHOUT WIND)</b>			
DURING FIRING																	
1	2													3	EX		
CALL	HOLD													CALL	HOLD	CALL	HOLD
4	5													CALL	HOLD	CALL	HOLD
		REMARKS															



**200 YARD SLOW-FIRE ANY POSITION** **BEFORE FIRING** **DAY ONE**

ZERO + WIND = HOLD

HOLDS IN INCHES

VALUE	5mph		10mph		15mph		20mph		25mph	
	M16A4	M4	M16A4	M4	M16A4	M4	M16A4	M4	M16A4	M4
FULL	2	3	5	5	7	8	9	10	11	19
HALF	1	1	2	2	3	4	4	5	5	9

---

**WEATHER DATA**

LIGHT

OVERCAST

PARTLY CLOUDY

CLEAR

PRECIP

DRY

LT RAIN

MIST

HVY RAIN

**PLOT**

**AFTER FIRING**

**SIGHT PICTURE ADJUSTMENT (WITHOUT WIND)**

---

**DURING FIRING**

1 2 3

CALL HOLD CALL HOLD

4 5 EX

CALL HOLD CALL HOLD

INCHES

**REMARKS**

**200 YARD SLOW-FIRE ANY POSITION** **BEFORE FIRING** **DAY ONE**

ZERO + WIND = HOLD

HOLDS IN INCHES

VALUE	5mph		10mph		15mph		20mph		25mph	
	M16A4	M4	M16A4	M4	M16A4	M4	M16A4	M4	M16A4	M4
FULL	2	3	5	5	7	8	9	10	11	19
HALF	1	1	2	2	3	4	4	5	5	9

---

**WEATHER DATA**

LIGHT

OVERCAST

PARTLY CLOUDY

CLEAR

PRECIP

DRY

LT RAIN

MIST

HVY RAIN

**PLOT**

**AFTER FIRING**

**SIGHT PICTURE ADJUSTMENT (WITHOUT WIND)**

---

**DURING FIRING**

1 2 3









CALL HOLD CALL HOLD

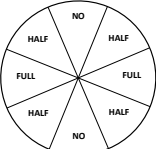





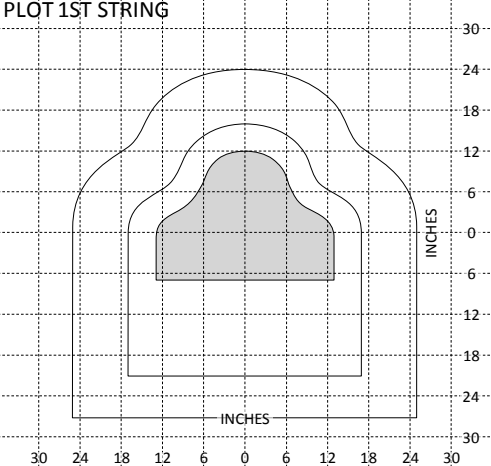
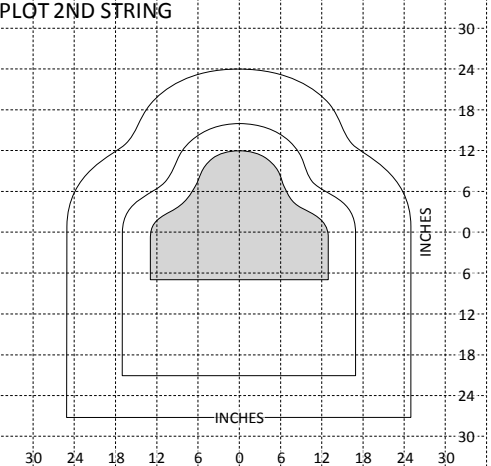
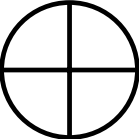

4 5 EX

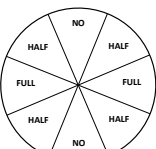
CALL HOLD CALL HOLD

INCHES

**REMARKS**

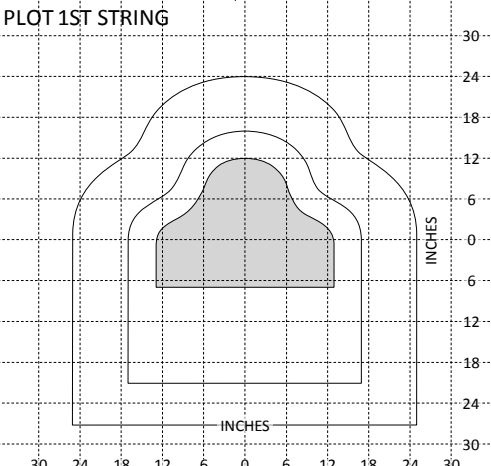
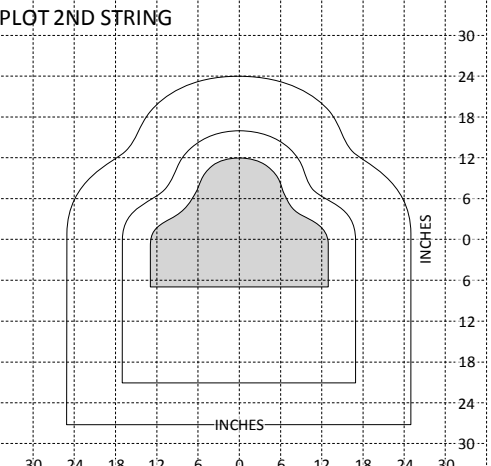
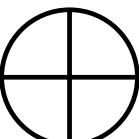
200 YARD RAPID-FIRE SITTING				BEFORE FIRING										DAY ONE																																
ZERO		+	WIND										=	HOLD																																
			HOLDS IN INCHES																																											
			<table border="1" style="font-size: small;"> <thead> <tr> <th>VALUE</th> <th colspan="2">5mph M16A4 M4</th> <th colspan="2">10mph M16A4 M4</th> <th colspan="2">15mph M16A4 M4</th> <th colspan="2">20mph M16A4 M4</th> <th colspan="2">25mph M16A4 M4</th> </tr> </thead> <tbody> <tr> <td>FULL</td> <td>2</td><td>3</td><td>5</td><td>5</td><td>7</td><td>8</td><td>9</td><td>10</td><td>11</td><td>19</td> </tr> <tr> <td>HALF</td> <td>1</td><td>1</td><td>2</td><td>2</td><td>3</td><td>4</td><td>4</td><td>5</td><td>5</td><td>9</td> </tr> </tbody> </table>	VALUE	5mph M16A4 M4		10mph M16A4 M4		15mph M16A4 M4		20mph M16A4 M4		25mph M16A4 M4		FULL	2	3	5	5	7	8	9	10	11	19	HALF	1	1	2	2	3	4	4	5	5	9										
VALUE	5mph M16A4 M4		10mph M16A4 M4		15mph M16A4 M4		20mph M16A4 M4		25mph M16A4 M4																																					
FULL	2	3	5	5	7	8	9	10	11	19																																				
HALF	1	1	2	2	3	4	4	5	5	9																																				
PLOT 1ST STRING			DURING FIRING										PLOT 2ND STRING																																	
			2ND STRING HOLD																																											
			REMARKS																																											
LIGHT <input type="checkbox"/> OVERCAST <input type="checkbox"/> PARTLY CLOUDY <input type="checkbox"/> CLEAR			PRECIP <input type="checkbox"/> DRY <input type="checkbox"/> LT RAIN <input type="checkbox"/> MIST <input type="checkbox"/> HVY RAIN		SIGHT PICTURE ADJUSTMENT (WITHOUT WIND)																																									

200 YARD RAPID-FIRE SITTING				BEFORE FIRING										DAY ONE																																
ZERO		+	WIND										=	HOLD																																
			HOLDS IN INCHES																																											
			<table border="1" style="font-size: small;"> <thead> <tr> <th>VALUE</th> <th colspan="2">5mph M16A4 M4</th> <th colspan="2">10mph M16A4 M4</th> <th colspan="2">15mph M16A4 M4</th> <th colspan="2">20mph M16A4 M4</th> <th colspan="2">25mph M16A4 M4</th> </tr> </thead> <tbody> <tr> <td>FULL</td> <td>2</td><td>3</td><td>5</td><td>5</td><td>7</td><td>8</td><td>9</td><td>10</td><td>11</td><td>19</td> </tr> <tr> <td>HALF</td> <td>1</td><td>1</td><td>2</td><td>2</td><td>3</td><td>4</td><td>4</td><td>5</td><td>5</td><td>9</td> </tr> </tbody> </table>	VALUE	5mph M16A4 M4		10mph M16A4 M4		15mph M16A4 M4		20mph M16A4 M4		25mph M16A4 M4		FULL	2	3	5	5	7	8	9	10	11	19	HALF	1	1	2	2	3	4	4	5	5	9										
VALUE	5mph M16A4 M4		10mph M16A4 M4		15mph M16A4 M4		20mph M16A4 M4		25mph M16A4 M4																																					
FULL	2	3	5	5	7	8	9	10	11	19																																				
HALF	1	1	2	2	3	4	4	5	5	9																																				
PLOT 1ST STRING			DURING FIRING										PLOT 2ND STRING																																	
			2ND STRING HOLD																																											
			REMARKS																																											
LIGHT <input type="checkbox"/> OVERCAST <input type="checkbox"/> PARTLY CLOUDY <input type="checkbox"/> CLEAR			PRECIP <input type="checkbox"/> DRY <input type="checkbox"/> LT RAIN <input type="checkbox"/> MIST <input type="checkbox"/> HVY RAIN		SIGHT PICTURE ADJUSTMENT (WITHOUT WIND)																																									

**300 YARD SLOW-FIRE SITTING** **BEFORE FIRING** **DAY ONE**

ZERO + WIND = **HOLD**

HOLDS IN INCHES

VALUE	5mph		10mph		15mph		20mph		25mph	
	M16A4	M4	M16A4	M4	M16A4	M4	M16A4	M4	M16A4	M4
FULL	5	6	11	13	16	18	22	25	27	32
HALF	2	3	5	6	8	9	11	12	13	16

---

**WEATHER DATA**

LIGHT

OVERCAST

PARTLY CLOUDY

CLEAR

PRECIP

DRY

LT RAIN

MIST

HVY RAIN

**PLOT**

INCHES

**AFTER FIRING**

**SIGHT PICTURE ADJUSTMENT (WITHOUT WIND)**

---

**DURING FIRING**

1 2 3

CALL HOLD

4 5 EX

CALL HOLD

**REMARKS**

**300 YARD SLOW-FIRE SITTING** **BEFORE FIRING** **DAY ONE**

ZERO + WIND = **HOLD**

HOLDS IN INCHES

VALUE	5mph		10mph		15mph		20mph		25mph	
	M16A4	M4	M16A4	M4	M16A4	M4	M16A4	M4	M16A4	M4
FULL	5	6	11	13	16	16	22	25	27	32
HALF	2	3	5	6	8	8	11	12	13	16

---

**WEATHER DATA**

LIGHT

OVERCAST

PARTLY CLOUDY

CLEAR

PRECIP

DRY

LT RAIN

MIST

HVY RAIN

**PLOT**

INCHES

**AFTER FIRING**

**SIGHT PICTURE ADJUSTMENT (WITHOUT WIND)**

---

**DURING FIRING**

1 2 3

CALL HOLD

4 5 EX

CALL HOLD

**REMARKS**

300 YARD RAPID-FIRE PRONE			BEFORE FIRING					DAY ONE					
ZERO		+	WIND					=		HOLD			
		HOLDS IN INCHES											
			VALUE	5mph M16A4 M4	10mph M16A4 M4	15mph M16A4 M4	20mph M16A4 M4	25mph M16A4 M4					
			FULL	5	6	11	13	16	16	22	25	27	32
			HALF	2	3	5	6	8	8	11	12	13	16
PLOT 1ST STRING		DURING FIRING					PLOT 2ND STRING						
		2ND STRING SIGHT PICTURE											
		REMARKS					SIGHT PICTURE ADJUSTMENT (WITHOUT WIND)						
LIGHT <input type="checkbox"/> OVERCAST <input type="checkbox"/> PARTLY CLOUDY <input type="checkbox"/> CLEAR		PRECIP <input type="checkbox"/> DRY <input type="checkbox"/> LT RAIN <input type="checkbox"/> MIST <input type="checkbox"/> HVY RAIN											

300 YARD RAPID-FIRE PRONE			BEFORE FIRING					DAY ONE					
ZERO		+	WIND					=		HOLD			
		HOLDS IN INCHES											
			VALUE	5mph M16A4 M4	10mph M16A4 M4	15mph M16A4 M4	20mph M16A4 M4	25mph M16A4 M4					
			FULL	5	6	11	13	16	16	22	25	27	32
			HALF	2	3	5	6	8	8	11	12	13	16
PLOT 1ST STRING		DURING FIRING					PLOT 2ND STRING						
		2ND STRING SIGHT PICTURE											
		REMARKS					SIGHT PICTURE ADJUSTMENT (WITHOUT WIND)						
LIGHT <input type="checkbox"/> OVERCAST <input type="checkbox"/> PARTLY CLOUDY <input type="checkbox"/> CLEAR		PRECIP <input type="checkbox"/> DRY <input type="checkbox"/> LT RAIN <input type="checkbox"/> MIST <input type="checkbox"/> HVY RAIN											

**500 YARD SLOW-FIRE PRONE** **BEFORE FIRING** **DAY ONE**

ZERO + WIND = HOLD

HOLDS IN INCHES

VALUE	5mph		10mph		15mph		20mph		25mph	
	M16A4	M4	M16A4	M4	M16A4	M4	M16A4	M4	M16A4	M4
FULL	17	20	35	40	52	60	69	81	87	101
HALF	8	10	17	20	26	30	34	40	43	50

	1	2	3	4	5
CALL					
HOLD					
	6	7	8	9	10
CALL					
HOLD					
	11	12	13	14	15
CALL					
HOLD					

**PLOT**

**REMARKS**

**WEATHER DATA**

LIGHT TYPE AND DIRECTION

CLEAR  OVERCAST

PARTLY CLOUDY

PRECIP

DRY  LT RAIN

MIST  HVY RAIN

---

**AFTER FIRING**

**SIGHT PICTURE ADJUSTMENT (WITHOUT WIND)**

**500 YARD SLOW-FIRE PRONE** **BEFORE FIRING** **DAY ONE**

ZERO + WIND = HOLD

HOLDS IN INCHES

VALUE	5mph		10mph		15mph		20mph		25mph	
	M16A4	M4	M16A4	M4	M16A4	M4	M16A4	M4	M16A4	M4
FULL	17	20	35	40	52	60	69	81	87	101
HALF	8	10	17	20	26	30	34	40	43	50

	1	2	3	4	5
CALL					
HOLD					
	6	7	8	9	10
CALL					
HOLD					
	11	12	13	14	15
CALL					
HOLD					

**PLOT**

**REMARKS**

**WEATHER DATA**

LIGHT TYPE AND DIRECTION

CLEAR  OVERCAST

PARTLY CLOUDY

PRECIP

DRY  LT RAIN

MIST  HVY RAIN

---

**AFTER FIRING**

**SIGHT PICTURE ADJUSTMENT (WITHOUT WIND)**

**200 YARD SLOW-FIRE SITTING** **BEFORE FIRING** **DAY TWO**

ZERO HOLD

+ WIND =

HOLDS IN INCHES

VALUE	5mph		10mph		15mph		20mph		25mph	
	M16A4	M4	M16A4	M4	M16A4	M4	M16A4	M4	M16A4	M4
FULL	2	3	5	5	7	8	9	10	11	19
HALF	1	1	2	2	3	4	4	5	5	9

**WEATHER DATA**

LIGHT  OVERCAST  PARTLY CLOUDY  CLEAR

PRECIP  DRY  LT RAIN  MIST  HVY RAIN

**DURING FIRING**

1 CALL HOLD 2 CALL HOLD 3 CALL HOLD

4 CALL HOLD 5 CALL HOLD EX CALL HOLD

**PLOT**

INCHES

**AFTER FIRING**

**SIGHT PICTURE ADJUSTMENT (WITHOUT WIND)**

**REMARKS**

**200 YARD SLOW-FIRE SITTING** **BEFORE FIRING** **DAY TWO**

ZERO HOLD

+ WIND =

HOLDS IN INCHES

VALUE	5mph		10mph		15mph		20mph		25mph	
	M16A4	M4	M16A4	M4	M16A4	M4	M16A4	M4	M16A4	M4
FULL	2	3	5	5	7	8	9	10	11	19
HALF	1	1	2	2	3	4	4	5	5	9

**WEATHER DATA**

LIGHT  OVERCAST  PARTLY CLOUDY  CLEAR

PRECIP  DRY  LT RAIN  MIST  HVY RAIN

**DURING FIRING**

1 CALL HOLD 2 CALL HOLD 3 CALL HOLD

4 CALL HOLD 5 CALL HOLD EX CALL HOLD



**PLOT**



INCHES



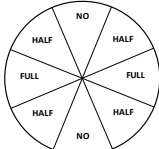

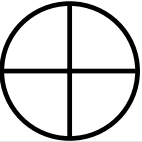
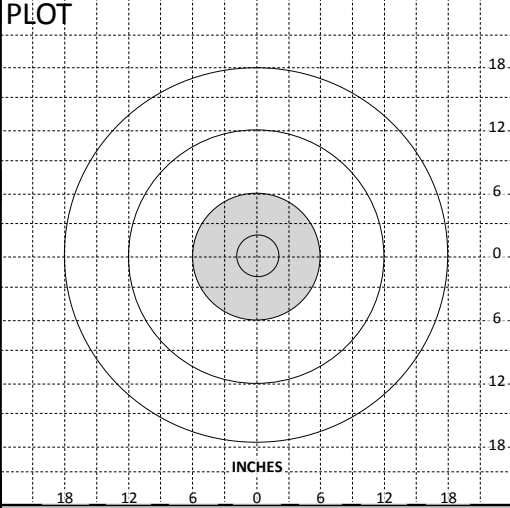

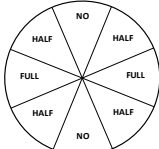

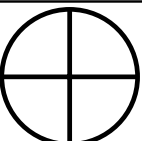
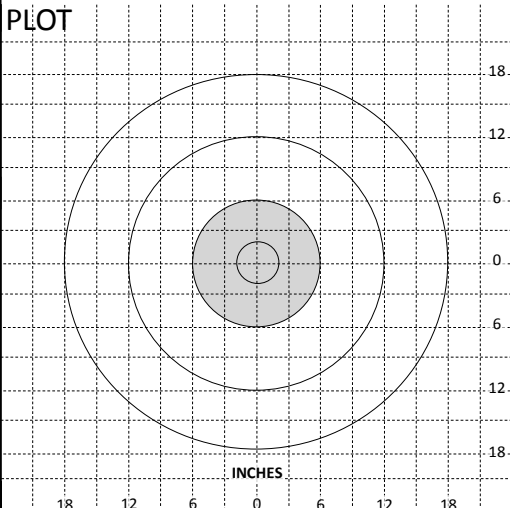

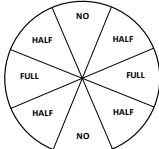
**AFTER FIRING**

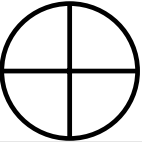
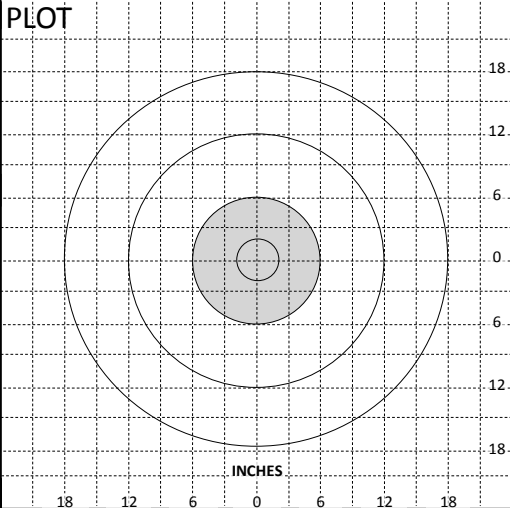

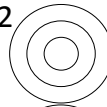

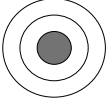
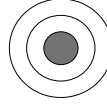
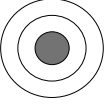
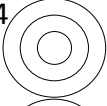
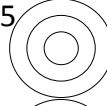

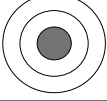
**SIGHT PICTURE ADJUSTMENT (WITHOUT WIND)**

**REMARKS**

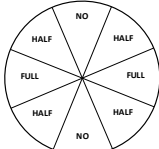

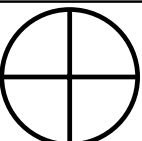
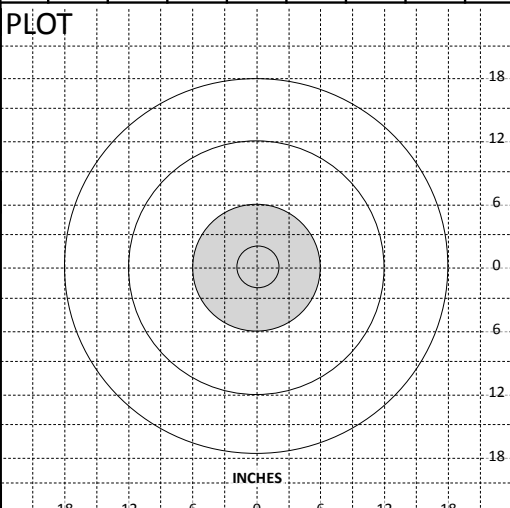



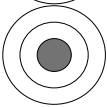
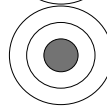
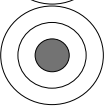
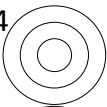
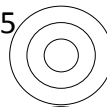
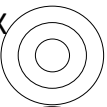
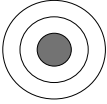
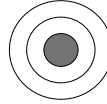
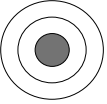

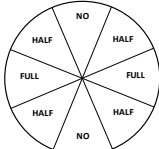

200 YARD SLOW-FIRE KNEELING				BEFORE FIRING										DAY TWO			
ZERO				+ WIND =										HOLD			
				HOLDS IN INCHES 													
				5mph		10mph		15mph		20mph		25mph					
				M16A4 M4		M16A4 M4		M16A4 M4		M16A4 M4		M16A4 M4					
				FULL		FULL		FULL		FULL		FULL					
				HALF		HALF		HALF		HALF		HALF					
<b>WEATHER DATA</b>				<b>PLOT</b>										<b>AFTER FIRING</b>			
LIGHT <input type="checkbox"/> OVERCAST <input type="checkbox"/> PARTLY CLOUDY <input type="checkbox"/> CLEAR				PRECIP <input type="checkbox"/> DRY <input type="checkbox"/> LT RAIN <input type="checkbox"/> MIST <input type="checkbox"/> HVY RAIN												<b>SIGHT PICTURE ADJUSTMENT (WITHOUT WIND)</b>	
<b>DURING FIRING</b>																	
1		2				3											
CALL																	
HOLD																	
4		5		EX		<b>REMARKS</b>											
CALL																	
HOLD																	

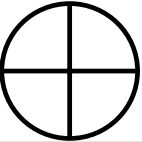
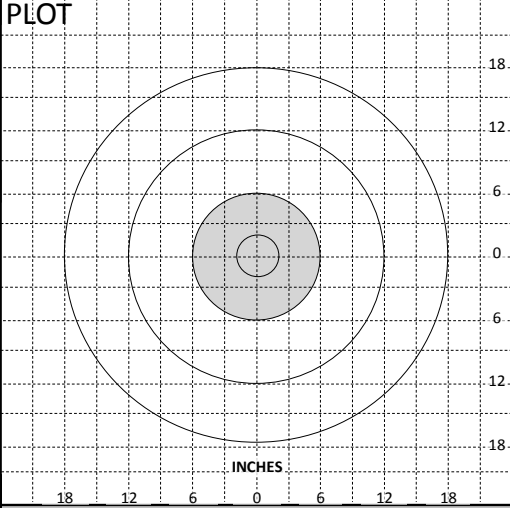







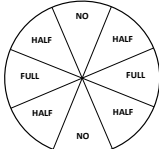

200 YARD SLOW-FIRE KNEELING				BEFORE FIRING										DAY TWO			
ZERO				+ WIND =										HOLD			
				HOLDS IN INCHES 													
				5mph		10mph		15mph		20mph		25mph					
				M16A4 M4		M16A4 M4		M16A4 M4		M16A4 M4		M16A4 M4					
				FULL		FULL		FULL		FULL		FULL					
				HALF		HALF		HALF		HALF		HALF					
<b>WEATHER DATA</b>				<b>PLOT</b>										<b>AFTER FIRING</b>			
LIGHT <input type="checkbox"/> OVERCAST <input type="checkbox"/> PARTLY CLOUDY <input type="checkbox"/> CLEAR				PRECIP <input type="checkbox"/> DRY <input type="checkbox"/> LT RAIN <input type="checkbox"/> MIST <input type="checkbox"/> HVY RAIN												<b>SIGHT PICTURE ADJUSTMENT (WITHOUT WIND)</b>	
<b>DURING FIRING</b>																	
1		2				3											
CALL																	
HOLD																	
4		5		EX		<b>REMARKS</b>											
CALL																	
HOLD																	

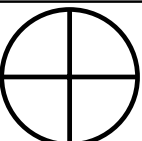
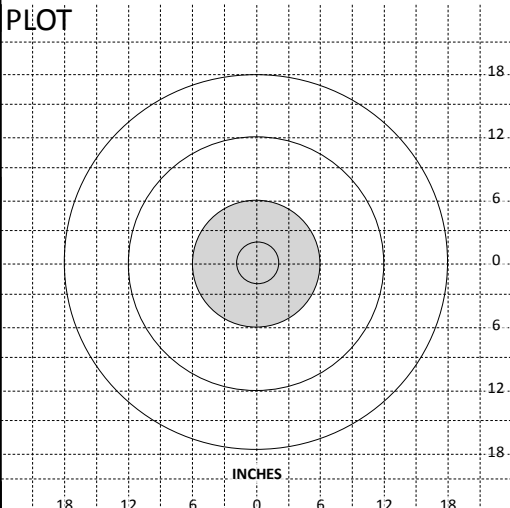



200 YARD SLOW-FIRE STANDING		BEFORE FIRING										DAY TWO			
ZERO		+ WIND =										HOLD			
		HOLDS IN INCHES													
		VALUE	5mph M16A4 M4		10mph M16A4 M4		15mph M16A4 M4		20mph M16A4 M4		25mph M16A4 M4				
		FULL	2	3	5	5	7	8	9	10	11	19			
		HALF	1	1	2	2	3	4	4	5	5	9			
WEATHER DATA		PLOT										AFTER FIRING			
LIGHT <input type="checkbox"/> OVERCAST <input type="checkbox"/> PARTLY CLOUDY <input type="checkbox"/> CLEAR														<b>SIGHT PICTURE ADJUSTMENT (WITHOUT WIND)</b>	
PRECIP <input type="checkbox"/> DRY <input type="checkbox"/> LT RAIN <input type="checkbox"/> MIST <input type="checkbox"/> HVY RAIN															
DURING FIRING		REMARKS													
1	2	3													
CALL															
HOLD															
4	5	EX													
CALL															
HOLD															



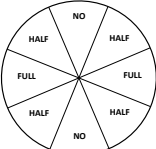

200 YARD SLOW-FIRE STANDING		BEFORE FIRING										DAY TWO			
ZERO		+ WIND =										HOLD			
		HOLDS IN INCHES													
		VALUE	5mph M16A4 M4		10mph M16A4 M4		15mph M16A4 M4		20mph M16A4 M4		25mph M16A4 M4				
		FULL	2	3	5	5	7	8	9	10	11	19			
		HALF	1	1	2	2	3	4	4	5	5	9			
WEATHER DATA		PLOT										AFTER FIRING			
LIGHT <input type="checkbox"/> OVERCAST <input type="checkbox"/> PARTLY CLOUDY <input type="checkbox"/> CLEAR														<b>SIGHT PICTURE ADJUSTMENT (WITHOUT WIND)</b>	
PRECIP <input type="checkbox"/> DRY <input type="checkbox"/> LT RAIN <input type="checkbox"/> MIST <input type="checkbox"/> HVY RAIN															
DURING FIRING		REMARKS													
1	2	3													
CALL															
HOLD															
4	5	EX													
CALL															
HOLD															

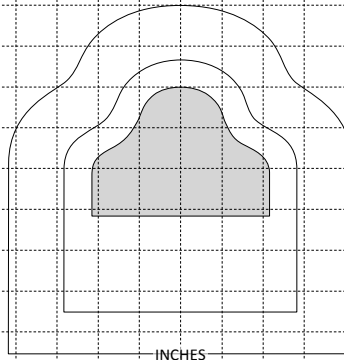
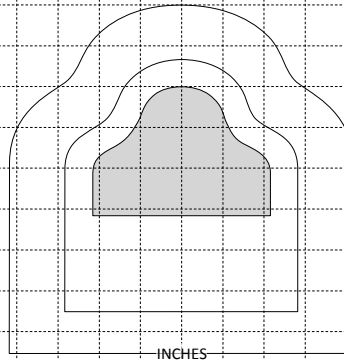
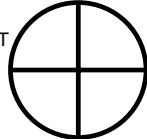



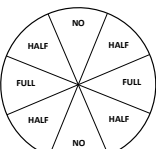

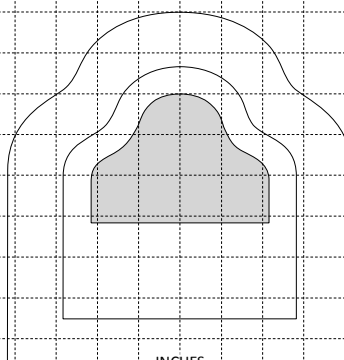
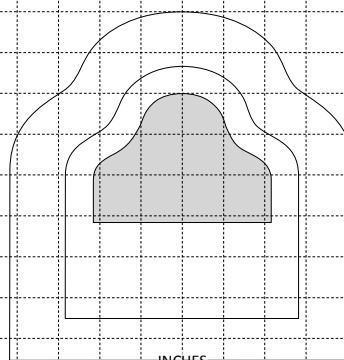
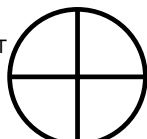



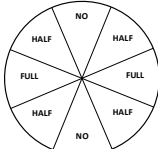

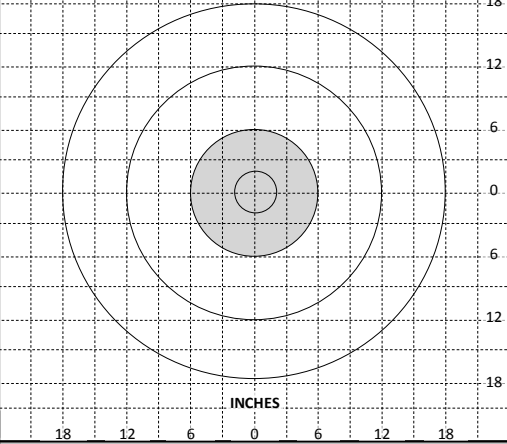

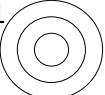

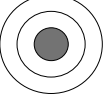
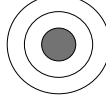
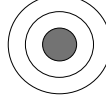
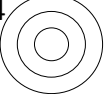

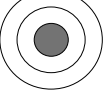
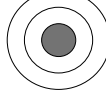
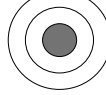



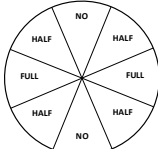

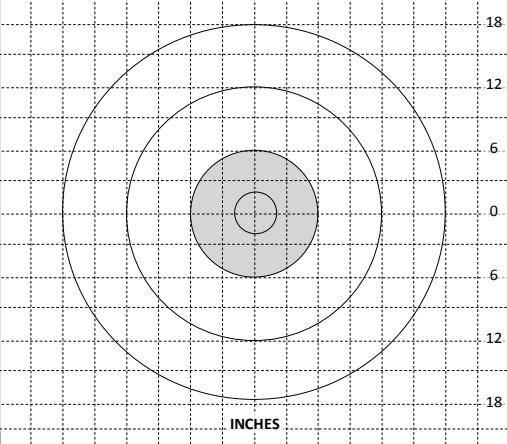

200 YARD SLOW-FIRE ANY POSITION		BEFORE FIRING										DAY TWO			
ZERO		+ WIND =										HOLD			
		HOLDS IN INCHES													
		VALUE	5mph M16A4 M4		10mph M16A4 M4		15mph M16A4 M4		20mph M16A4 M4		25mph M16A4 M4				
		FULL	2	3	5	5	7	8	9	10	11	19			
		HALF	1	1	2	2	3	4	4	5	5	9			
WEATHER DATA		PLOT										AFTER FIRING			
LIGHT <input type="checkbox"/> OVERCAST <input type="checkbox"/> PARTLY CLOUDY <input type="checkbox"/> CLEAR 		PRECIP <input type="checkbox"/> DRY <input type="checkbox"/> LT RAIN <input type="checkbox"/> MIST <input type="checkbox"/> HVY RAIN												<b>SIGHT PICTURE ADJUSTMENT (WITHOUT WIND)</b>	
<b>DURING FIRING</b>														<b>REMARKS</b>	
1  2  3  CALL    HOLD    HOLD		4  5  EX  CALL    HOLD    HOLD													



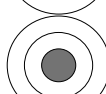
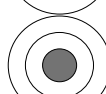

200 YARD SLOW-FIRE ANY POSITION		BEFORE FIRING										DAY TWO			
ZERO		+ WIND =										HOLD			
		HOLDS IN INCHES													
		VALUE	5mph M16A4 M4		10mph M16A4 M4		15mph M16A4 M4		20mph M16A4 M4		25mph M16A4 M4				
		FULL	2	3	5	5	7	8	9	10	11	19			
		HALF	1	1	2	2	3	4	4	5	5	9			
WEATHER DATA		PLOT										AFTER FIRING			
LIGHT <input type="checkbox"/> OVERCAST <input type="checkbox"/> PARTLY CLOUDY <input type="checkbox"/> CLEAR 		PRECIP <input type="checkbox"/> DRY <input type="checkbox"/> LT RAIN <input type="checkbox"/> MIST <input type="checkbox"/> HVY RAIN												<b>SIGHT PICTURE ADJUSTMENT (WITHOUT WIND)</b>	
<b>DURING FIRING</b>														<b>REMARKS</b>	
1  2  3  CALL    HOLD    HOLD		4  5  EX  CALL    HOLD    HOLD													

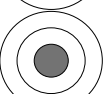

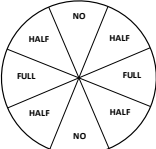

200 YARD RAPID-FIRE SITTING										BEFORE FIRING										DAY TWO														
ZERO					+ WIND =										HOLD																			
																																		
					HOLDS IN INCHES		5mph		10mph		15mph		20mph		25mph																			
					M16A4		M4		M16A4		M4		M16A4		M4																			
					FULL		2		3		5		5		7		8		9		10		11		19									
					HALF		1		1		2		2		3		4		4		5		5		9									
PLOT 1ST STRING															<b>DURING FIRING</b>										PLOT 2ND STRING									
															<b>2ND STRING HOLD</b>																			
															<b>REMARKS</b>																			
LIGHT <input type="checkbox"/> OVERCAST <input type="checkbox"/> PARTLY CLOUDY <input type="checkbox"/> CLEAR										PRECIP <input type="checkbox"/> DRY <input type="checkbox"/> LT RAIN <input type="checkbox"/> MIST <input type="checkbox"/> HVY RAIN					<b>SIGHT PICTURE ADJUSTMENT (WITHOUT WIND)</b>																			

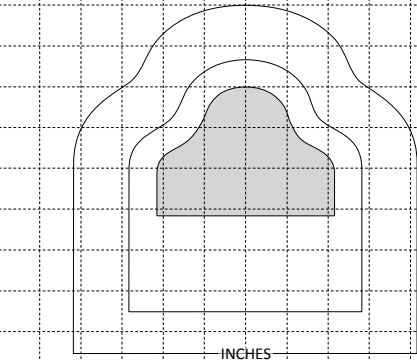
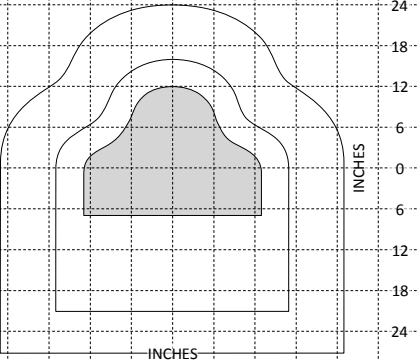
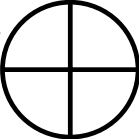
200 YARD RAPID-FIRE SITTING										BEFORE FIRING										DAY TWO														
ZERO					+ WIND =										HOLD																			
																																		
					HOLDS IN INCHES		5mph		10mph		15mph		20mph		25mph																			
					M16A4		M4		M16A4		M4		M16A4		M4																			
					FULL		2		3		5		5		7		8		9		10		11		19									
					HALF		1		1		2		2		3		4		4		5		5		9									
PLOT 1ST STRING															<b>DURING FIRING</b>										PLOT 2ND STRING									
															<b>2ND STRING HOLD</b>																			
															<b>REMARKS</b>																			
LIGHT <input type="checkbox"/> OVERCAST <input type="checkbox"/> PARTLY CLOUDY <input type="checkbox"/> CLEAR										PRECIP <input type="checkbox"/> DRY <input type="checkbox"/> LT RAIN <input type="checkbox"/> MIST <input type="checkbox"/> HVY RAIN					<b>SIGHT PICTURE ADJUSTMENT (WITHOUT WIND)</b>																			

300 YARD SLOW-FIRE SITTING		BEFORE FIRING										DAY TWO		
ZERO		+ WIND =										HOLD		
		HOLDS IN INCHES												
		5mph		10mph		15mph		20mph		25mph				
		VALUE	M16A4	M4	M16A4	M4	M16A4	M4	M16A4	M4	M16A4	M4		
		FULL	5	6	11	13	16	16	22	25	27	32		
		HALF	2	3	5	6	8	8	11	12	13	16		
WEATHER DATA		PLOT										AFTER FIRING		
LIGHT <input type="checkbox"/> OVERCAST <input type="checkbox"/> PARTLY CLOUDY <input type="checkbox"/> CLEAR												<b>SIGHT PICTURE ADJUSTMENT (WITHOUT WIND)</b>		
PRECIP <input type="checkbox"/> DRY <input type="checkbox"/> LT RAIN <input type="checkbox"/> MIST <input type="checkbox"/> HVY RAIN														
DURING FIRING		REMARKS												
1      2      3 CALL    HOLD    4      5      EX CALL    HOLD   														

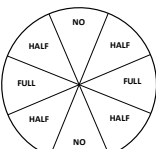
300 YARD SLOW-FIRE SITTING		BEFORE FIRING										DAY TWO		
ZERO		+ WIND =										HOLD		
		HOLDS IN INCHES												
		5mph		10mph		15mph		20mph		25mph				
		VALUE	M16A4	M4	M16A4	M4	M16A4	M4	M16A4	M4	M16A4	M4		
		FULL	5	6	11	13	16	16	22	25	27	32		
		HALF	2	3	5	6	8	8	11	12	13	16		
WEATHER DATA		PLOT										AFTER FIRING		
LIGHT <input type="checkbox"/> OVERCAST <input type="checkbox"/> PARTLY CLOUDY <input type="checkbox"/> CLEAR												<b>SIGHT PICTURE ADJUSTMENT (WITHOUT WIND)</b>		
PRECIP <input type="checkbox"/> DRY <input type="checkbox"/> LT RAIN <input type="checkbox"/> MIST <input type="checkbox"/> HVY RAIN														
DURING FIRING		REMARKS												
1      2      3 CALL    HOLD    4      5      EX CALL    HOLD   														

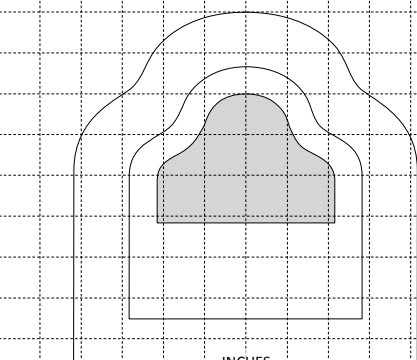
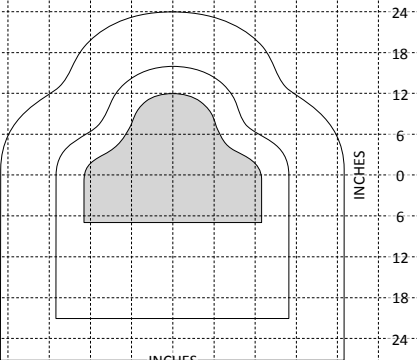
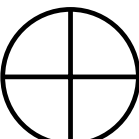
300 YARD RAPID-FIRE PRONE										BEFORE FIRING					DAY TWO				
ZERO					+	WIND					=	HOLD							
										HOLDS IN INCHES 									
		VALUE		5mph M16A4 M4		10mph M16A4 M4		15mph M16A4 M4		20mph M16A4 M4		25mph M16A4 M4							
		FULL		5		6		11		13		16		16					
		HALF		2		3		5		6		8		8					
PLOT 1ST STRING					DURING FIRING					PLOT 2ND STRING									
					2ND STRING SIGHT PICTURE														
					REMARKS														
LIGHT <input type="checkbox"/> OVERCAST <input type="checkbox"/> PARTLY CLOUDY <input type="checkbox"/> CLEAR				PRECIP <input type="checkbox"/> DRY <input type="checkbox"/> LT RAIN <input type="checkbox"/> MIST <input type="checkbox"/> HVY RAIN		SIGHT PICTURE ADJUSTMENT (WITHOUT WIND)													









300 YARD RAPID-FIRE PRONE										BEFORE FIRING					DAY TWO				
ZERO					+	WIND					=	HOLD							
										HOLDS IN INCHES 									
		VALUE		5mph M16A4 M4		10mph M16A4 M4		15mph M16A4 M4		20mph M16A4 M4		25mph M16A4 M4							
		FULL		5		6		11		13		16		16					
		HALF		2		3		5		6		8		8					
PLOT 1ST STRING					DURING FIRING					PLOT 2ND STRING									
					2ND STRING SIGHT PICTURE														
					REMARKS														
LIGHT <input type="checkbox"/> OVERCAST <input type="checkbox"/> PARTLY CLOUDY <input type="checkbox"/> CLEAR				PRECIP <input type="checkbox"/> DRY <input type="checkbox"/> LT RAIN <input type="checkbox"/> MIST <input type="checkbox"/> HVY RAIN		SIGHT PICTURE ADJUSTMENT (WITHOUT WIND)													

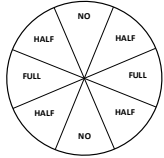

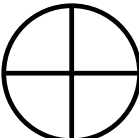
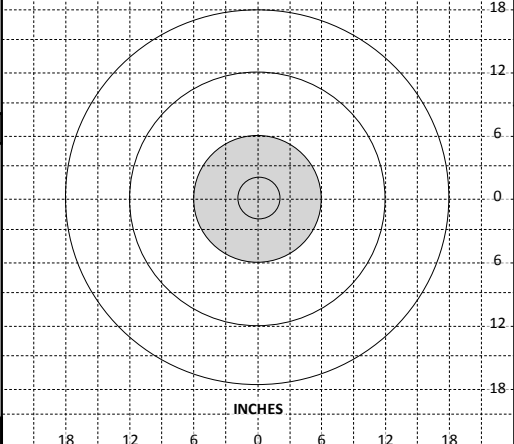

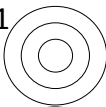
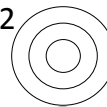
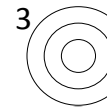
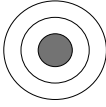
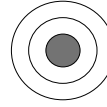
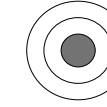
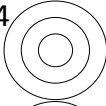
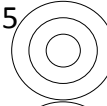

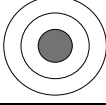
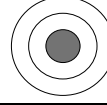
500 YARD SLOW-FIRE PRONE										BEFORE FIRING										DAY TWO									
ZERO					WIND										HOLD														
					5mph		10mph		15mph		20mph		25mph																
					M16A4	M4	M16A4	M4	M16A4	M4	M16A4	M4	M16A4	M4															
					FULL	17	20	35	40	52	60	69	81	87	101														
					HALF	8	10	17	20	26	30	34	40	43	50														
CALL  1  2  3  4  5 HOLD  1  2  3  4  5 CALL  6  7  8  9  10 HOLD  1  2  3  4  5 CALL  11  12  13  14  15 HOLD  1  2  3  4  5					<b>PLOT</b> 										<b>WEATHER DATA</b> LIGHT TYPE AND DIRECTION <input type="checkbox"/> CLEAR <input type="checkbox"/> OVERCAST <input type="checkbox"/> PARTLY CLOUDY PRECIP <input type="checkbox"/> DRY <input type="checkbox"/> LT RAIN <input type="checkbox"/> MIST <input type="checkbox"/> HVY RAIN														
<b>REMARKS</b>															<b>AFTER FIRING</b> <b>SIGHT PICTURE ADJUSTMENT (WITHOUT WIND)</b> 														



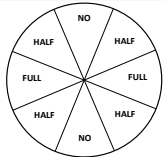

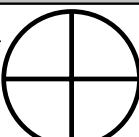
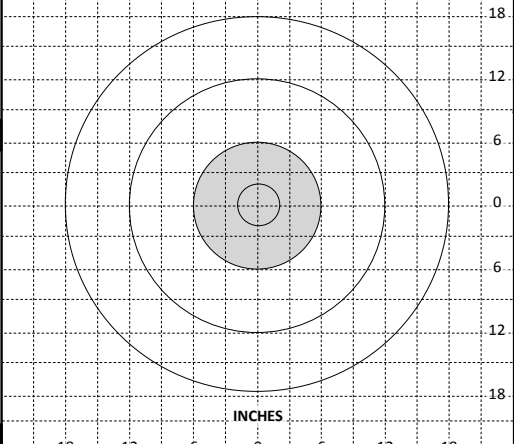
500 YARD SLOW-FIRE PRONE										BEFORE FIRING										DAY TWO									
ZERO					WIND										HOLD														
					5mph		10mph		15mph		20mph		25mph																
					M16A4	M4	M16A4	M4	M16A4	M4	M16A4	M4	M16A4	M4															
					FULL	17	20	35	40	52	60	69	81	87	101														
					HALF	8	10	17	20	26	30	34	40	43	50														
CALL  1  2  3  4  5 HOLD  1  2  3  4  5 CALL  6  7  8  9  10 HOLD  1  2  3  4  5 CALL  11  12  13  14  15 HOLD  1  2  3  4  5					<b>PLOT</b> 										<b>WEATHER DATA</b> LIGHT TYPE AND DIRECTION <input type="checkbox"/> CLEAR <input type="checkbox"/> OVERCAST <input type="checkbox"/> PARTLY CLOUDY PRECIP <input type="checkbox"/> DRY <input type="checkbox"/> LT RAIN <input type="checkbox"/> MIST <input type="checkbox"/> HVY RAIN														
<b>REMARKS</b>															<b>AFTER FIRING</b> <b>SIGHT PICTURE ADJUSTMENT (WITHOUT WIND)</b> 														

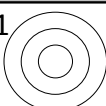
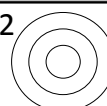
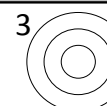
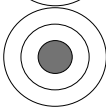
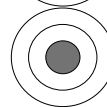
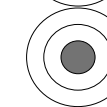
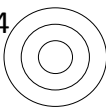
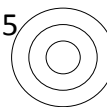

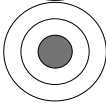
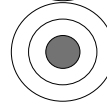
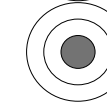

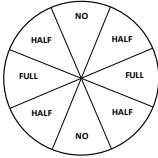

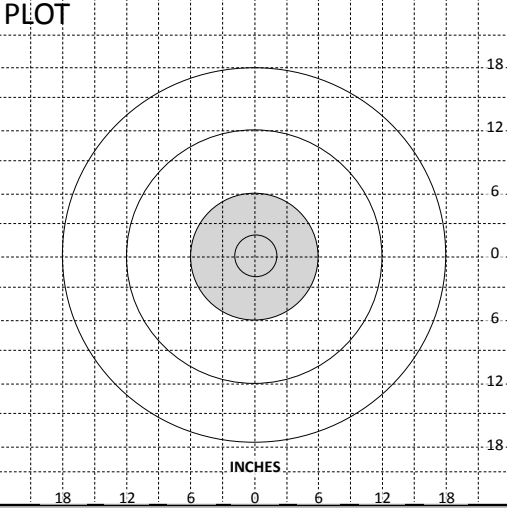
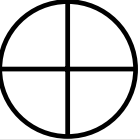
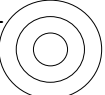
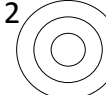
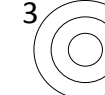
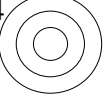
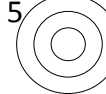

200 YARD SLOW-FIRE SITTING			BEFORE FIRING										DAY THREE EVALUATION				
ZERO			+ WIND =										HOLD				
		HOLDS IN INCHES		5mph M16A4 M4		10mph M16A4 M4		15mph M16A4 M4		20mph M16A4 M4		25mph M16A4 M4					
		VALUE		FULL		FULL		FULL		FULL		FULL					
		HALF		HALF		HALF		HALF		HALF		HALF					
<b>WEATHER DATA</b>				<b>PLOT</b>										<b>AFTER FIRING</b>			
LIGHT <input type="checkbox"/> OVERCAST <input type="checkbox"/> PARTLY CLOUDY <input type="checkbox"/> CLEAR				PRECIP <input type="checkbox"/> DRY <input type="checkbox"/> LT RAIN <input type="checkbox"/> MIST <input type="checkbox"/> HVY RAIN												<b>SIGHT PICTURE ADJUSTMENT (WITHOUT WIND)</b>	
<b>DURING FIRING</b>				<b>REMARKS</b>													
1		2		3													
CALL		HOLD		HOLD													
4		5		EX													
CALL		HOLD		HOLD													

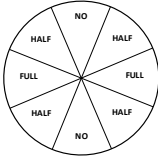
200 YARD SLOW-FIRE SITTING			BEFORE FIRING										DAY THREE EVALUATION				
ZERO			+ WIND =										HOLD				
		HOLDS IN INCHES		5mph M16A4 M4		10mph M16A4 M4		15mph M16A4 M4		20mph M16A4 M4		25mph M16A4 M4					
		VALUE		FULL		FULL		FULL		FULL		FULL					
		HALF		HALF		HALF		HALF		HALF		HALF					
<b>WEATHER DATA</b>				<b>PLOT</b>										<b>AFTER FIRING</b>			
LIGHT <input type="checkbox"/> OVERCAST <input type="checkbox"/> PARTLY CLOUDY <input type="checkbox"/> CLEAR				PRECIP <input type="checkbox"/> DRY <input type="checkbox"/> LT RAIN <input type="checkbox"/> MIST <input type="checkbox"/> HVY RAIN												<b>SIGHT PICTURE ADJUSTMENT (WITHOUT WIND)</b>	
<b>DURING FIRING</b>				<b>REMARKS</b>													
1		2		3													
CALL		HOLD		HOLD													
4		5		EX													
CALL		HOLD		HOLD													

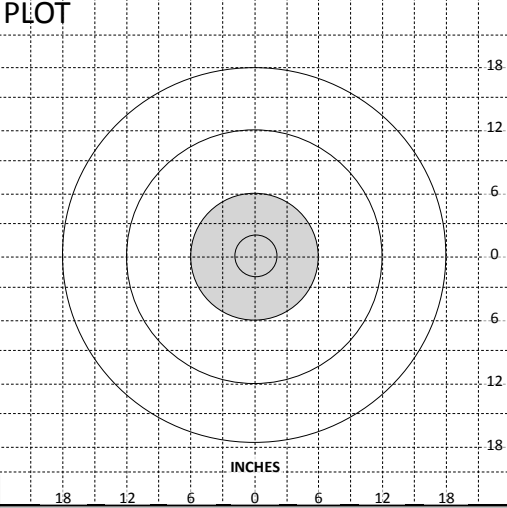
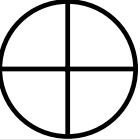
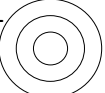

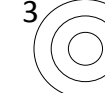

200 YARD SLOW-FIRE KNEELING			BEFORE FIRING										DAY THREE EVALUATION				
ZERO		+ WIND =										HOLD					
				HOLDS IN INCHES													
				5mph		10mph		15mph		20mph		25mph					
				M16A4 M4		M16A4 M4		M16A4 M4		M16A4 M4		M16A4 M4					
				FULL		FULL		FULL		FULL		FULL					
				HALF		HALF		HALF		HALF		HALF					
<b>WEATHER DATA</b>				<b>PLOT</b>										<b>AFTER FIRING</b>			
LIGHT <input type="checkbox"/> OVERCAST <input type="checkbox"/> PARTLY CLOUDY <input type="checkbox"/> CLEAR				PRECIP <input type="checkbox"/> DRY <input type="checkbox"/> LT RAIN <input type="checkbox"/> MIST <input type="checkbox"/> HVY RAIN												<b>SIGHT PICTURE ADJUSTMENT (WITHOUT WIND)</b>	
<b>DURING FIRING</b>				<b>REMARKS</b>													
				1		2		3									
CALL																	
HOLD																	
		4		5		EX											
CALL																	
HOLD																	



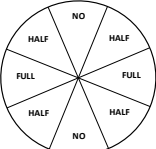

200 YARD SLOW-FIRE KNEELING			BEFORE FIRING										DAY THREE EVALUATION				
ZERO		+ WIND =										HOLD					
				HOLDS IN INCHES													
				5mph		10mph		15mph		20mph		25mph					
				M16A4 M4		M16A4 M4		M16A4 M4		M16A4 M4		M16A4 M4					
				FULL		FULL		FULL		FULL		FULL					
				HALF		HALF		HALF		HALF		HALF					
<b>WEATHER DATA</b>				<b>PLOT</b>										<b>AFTER FIRING</b>			
LIGHT <input type="checkbox"/> OVERCAST <input type="checkbox"/> PARTLY CLOUDY <input type="checkbox"/> CLEAR				PRECIP <input type="checkbox"/> DRY <input type="checkbox"/> LT RAIN <input type="checkbox"/> MIST <input type="checkbox"/> HVY RAIN												<b>SIGHT PICTURE ADJUSTMENT (WITHOUT WIND)</b>	
<b>DURING FIRING</b>				<b>REMARKS</b>													
				1		2		3									
CALL																	
HOLD																	
		4		5		EX											
CALL																	
HOLD																	

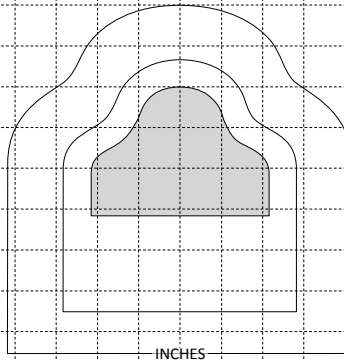
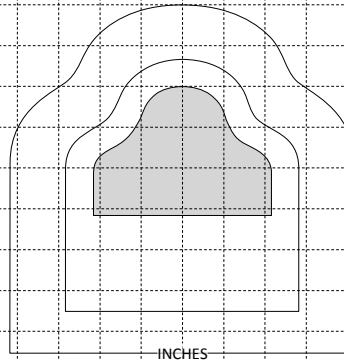
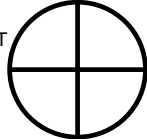





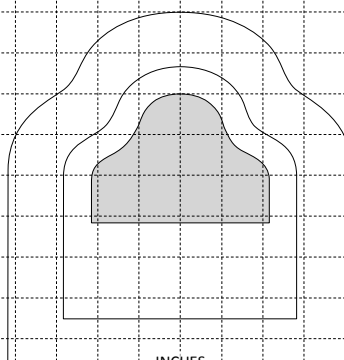
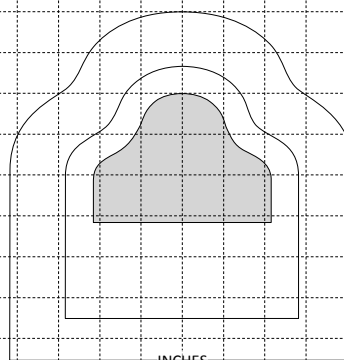
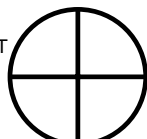

200 YARD SLOW-FIRE STANDING		BEFORE FIRING										DAY THREE EVALUATION							
ZERO		+ WIND =										HOLD							
				HOLDS IN INCHES 															
				5mph		10mph		15mph		20mph		25mph							
				M16A4	M4	M16A4	M4	M16A4	M4	M16A4	M4	M16A4	M4						
				FULL	2	3	5	5	7	8	9	10	11	19					
				HALF	1	1	2	2	3	4	4	5	5	9					
WEATHER DATA				PLOT										AFTER FIRING					
LIGHT <input type="checkbox"/> OVERCAST <input type="checkbox"/> PARTLY CLOUDY <input type="checkbox"/> CLEAR				PRECIP <input type="checkbox"/> DRY <input type="checkbox"/> LT RAIN <input type="checkbox"/> MIST <input type="checkbox"/> HVY RAIN														<b>SIGHT PICTURE ADJUSTMENT (WITHOUT WIND)</b>	
				<b>DURING FIRING</b>		1  2  3  CALL   HOLD   HOLD												4  5  EX  CALL   HOLD   HOLD	
<b>REMARKS</b>																			

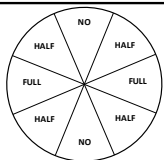
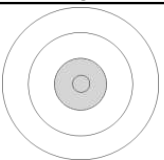

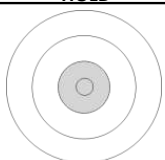
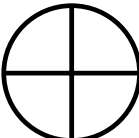
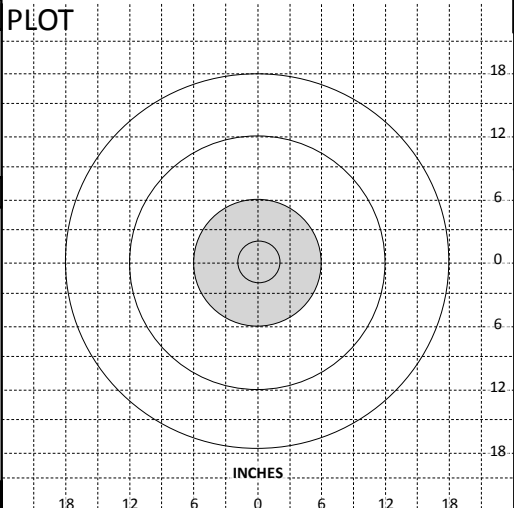
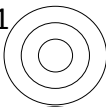
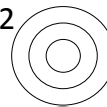
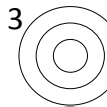

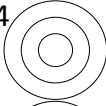
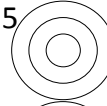

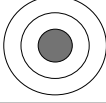
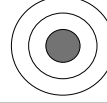

200 YARD SLOW-FIRE STANDING		BEFORE FIRING										DAY THREE EVALUATION							
ZERO		+ WIND =										HOLD							
				HOLDS IN INCHES 															
				5mph		10mph		15mph		20mph		25mph							
				M16A4	M4	M16A4	M4	M16A4	M4	M16A4	M4	M16A4	M4						
				FULL	2	3	5	5	7	8	9	10	11	19					
				HALF	1	1	2	2	3	4	4	5	5	9					
WEATHER DATA				PLOT										AFTER FIRING					
LIGHT <input type="checkbox"/> OVERCAST <input type="checkbox"/> PARTLY CLOUDY <input type="checkbox"/> CLEAR				PRECIP <input type="checkbox"/> DRY <input type="checkbox"/> LT RAIN <input type="checkbox"/> MIST <input type="checkbox"/> HVY RAIN														<b>SIGHT PICTURE ADJUSTMENT (WITHOUT WIND)</b>	
				<b>DURING FIRING</b>		1  2  3  CALL   HOLD   HOLD												4  5  EX  CALL   HOLD   HOLD	
<b>REMARKS</b>																			

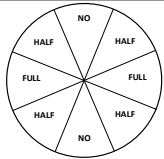
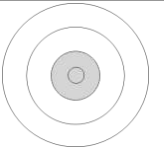

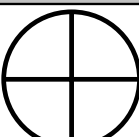
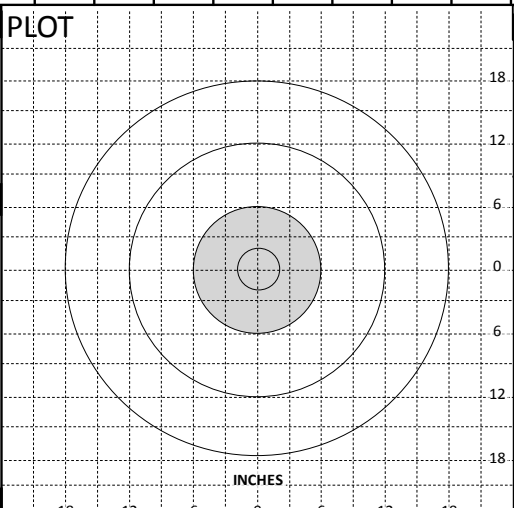
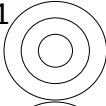
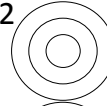
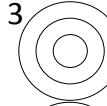

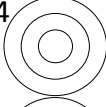
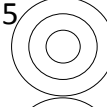

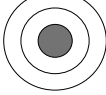
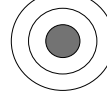

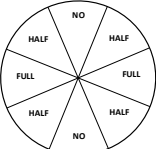

200 YARD RAPID-FIRE SITTING		BEFORE FIRING										DAY THREE EVALUATION		
ZERO		+ WIND =										HOLD		
		HOLDS IN INCHES												
		VALUE	5mph M16A4 M4		10mph M16A4 M4		15mph M16A4 M4		20mph M16A4 M4		25mph M16A4 M4			
		FULL	2	3	5	5	7	8	9	10	11	19		
		HALF	1	1	2	2	3	4	4	5	5	9		
PLOT 1ST STRING		DURING FIRING										PLOT ALIBI		
		ALIBI HOLD												
INCHES		REMARKS										INCHES		
30 24 18 12 6 0 6 12 18 24 30		30 24 18 12 6 0 6 12 18 24 30										30 24 18 12 6 0 6 12 18 24 30		
LIGHT <input type="checkbox"/> OVERCAST <input type="checkbox"/> PARTLY CLOUDY <input type="checkbox"/> CLEAR				PRECIP <input type="checkbox"/> DRY <input type="checkbox"/> LT RAIN <input type="checkbox"/> MIST <input type="checkbox"/> HVY RAIN		SIGHT PICTURE ADJUSTMENT (WITHOUT WIND)								

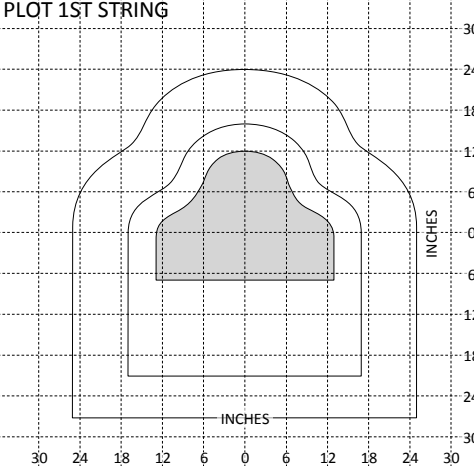
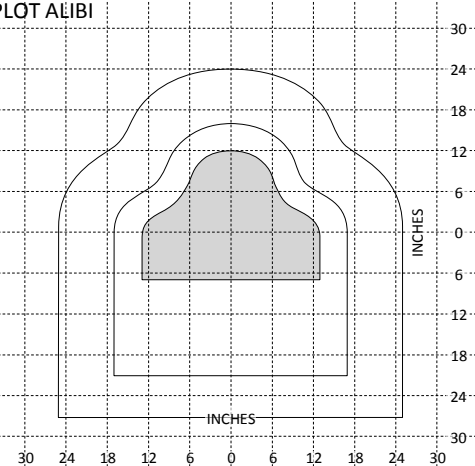
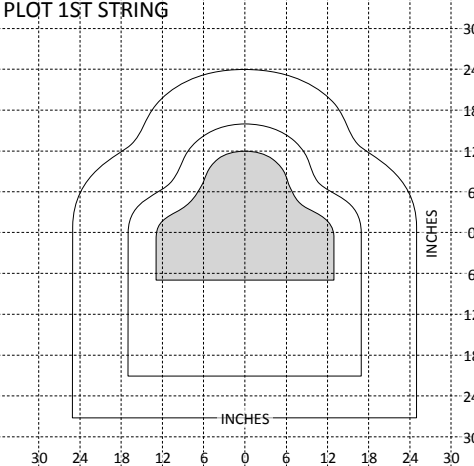
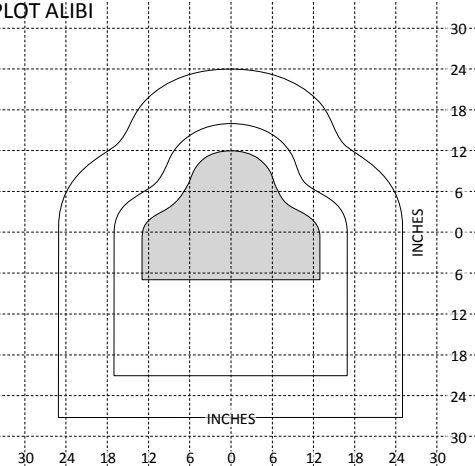
200 YARD RAPID-FIRE SITTING		BEFORE FIRING										DAY THREE EVALUATION		
ZERO		+ WIND =										HOLD		
		HOLDS IN INCHES												
		VALUE	5mph M16A4 M4		10mph M16A4 M4		15mph M16A4 M4		20mph M16A4 M4		25mph M16A4 M4			
		FULL	2	3	5	5	7	8	9	10	11	19		
		HALF	1	1	2	2	3	4	4	5	5	9		
PLOT 1ST STRING		DURING FIRING										PLOT ALIBI		
		ALIBI HOLD												
INCHES		REMARKS										INCHES		
30 24 18 12 6 0 6 12 18 24 30		30 24 18 12 6 0 6 12 18 24 30										30 24 18 12 6 0 6 12 18 24 30		
LIGHT <input type="checkbox"/> OVERCAST <input type="checkbox"/> PARTLY CLOUDY <input type="checkbox"/> CLEAR				PRECIP <input type="checkbox"/> DRY <input type="checkbox"/> LT RAIN <input type="checkbox"/> MIST <input type="checkbox"/> HVY RAIN		SIGHT PICTURE ADJUSTMENT (WITHOUT WIND)								

300 YARD SLOW-FIRE SITTING			BEFORE FIRING										DAY THREE EVALUATION																													
ZERO			+ WIND =										HOLD																													
																																										
		HOLDS IN INCHES		<table border="1" style="font-size: small;"> <tr> <th>VALUE</th> <th colspan="2">5mph</th> <th colspan="2">10mph</th> <th colspan="2">15mph</th> <th colspan="2">20mph</th> <th colspan="2">25mph</th> </tr> <tr> <td>FULL</td> <td>M16A4</td> <td>M4</td> <td>M16A4</td> <td>M4</td> <td>M16A4</td> <td>M4</td> <td>M16A4</td> <td>M4</td> <td>M16A4</td> <td>M4</td> </tr> <tr> <td>HALF</td> <td>5</td> <td>6</td> <td>11</td> <td>13</td> <td>16</td> <td>16</td> <td>22</td> <td>25</td> <td>27</td> <td>32</td> </tr> </table>		VALUE	5mph		10mph		15mph		20mph		25mph		FULL	M16A4	M4	M16A4	M4	M16A4	M4	M16A4	M4	M16A4	M4	HALF	5	6	11	13	16	16	22	25	27	32				
VALUE	5mph		10mph		15mph		20mph		25mph																																	
FULL	M16A4	M4	M16A4	M4	M16A4	M4	M16A4	M4	M16A4	M4																																
HALF	5	6	11	13	16	16	22	25	27	32																																
<b>WEATHER DATA</b>			<b>PLOT</b>										<b>AFTER FIRING</b>																													
LIGHT <input type="checkbox"/> OVERCAST <input type="checkbox"/> PARTLY CLOUDY <input type="checkbox"/> CLEAR			PRECIP <input type="checkbox"/> DRY <input type="checkbox"/> LT RAIN <input type="checkbox"/> MIST <input type="checkbox"/> HVY RAIN												<b>SIGHT PICTURE ADJUSTMENT (WITHOUT WIND)</b>																											
<b>DURING FIRING</b>			<b>REMARKS</b>																																							
		1  2  3 																																								
CALL																																										
HOLD																																										
		4  5  EX 																																								
CALL																																										
HOLD																																										
		4  5  EX 																																								
CALL																																										
HOLD																																										

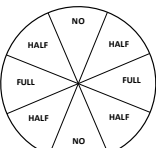
300 YARD SLOW-FIRE SITTING			BEFORE FIRING										DAY THREE EVALUATION																													
ZERO			+ WIND =										HOLD																													
																																										
		HOLDS IN INCHES		<table border="1" style="font-size: small;"> <tr> <th>VALUE</th> <th colspan="2">5mph</th> <th colspan="2">10mph</th> <th colspan="2">15mph</th> <th colspan="2">20mph</th> <th colspan="2">25mph</th> </tr> <tr> <td>FULL</td> <td>M16A4</td> <td>M4</td> <td>M16A4</td> <td>M4</td> <td>M16A4</td> <td>M4</td> <td>M16A4</td> <td>M4</td> <td>M16A4</td> <td>M4</td> </tr> <tr> <td>HALF</td> <td>5</td> <td>6</td> <td>11</td> <td>13</td> <td>16</td> <td>16</td> <td>22</td> <td>25</td> <td>27</td> <td>32</td> </tr> </table>		VALUE	5mph		10mph		15mph		20mph		25mph		FULL	M16A4	M4	M16A4	M4	M16A4	M4	M16A4	M4	M16A4	M4	HALF	5	6	11	13	16	16	22	25	27	32				
VALUE	5mph		10mph		15mph		20mph		25mph																																	
FULL	M16A4	M4	M16A4	M4	M16A4	M4	M16A4	M4	M16A4	M4																																
HALF	5	6	11	13	16	16	22	25	27	32																																
<b>WEATHER DATA</b>			<b>PLOT</b>										<b>AFTER FIRING</b>																													
LIGHT <input type="checkbox"/> OVERCAST <input type="checkbox"/> PARTLY CLOUDY <input type="checkbox"/> CLEAR			PRECIP <input type="checkbox"/> DRY <input type="checkbox"/> LT RAIN <input type="checkbox"/> MIST <input type="checkbox"/> HVY RAIN												<b>SIGHT PICTURE ADJUSTMENT (WITHOUT WIND)</b>																											
<b>DURING FIRING</b>			<b>REMARKS</b>																																							
		1  2  3 																																								
CALL																																										
HOLD																																										
		4  5  EX 																																								
CALL																																										
HOLD																																										
		4  5  EX 																																								
CALL																																										
HOLD																																										

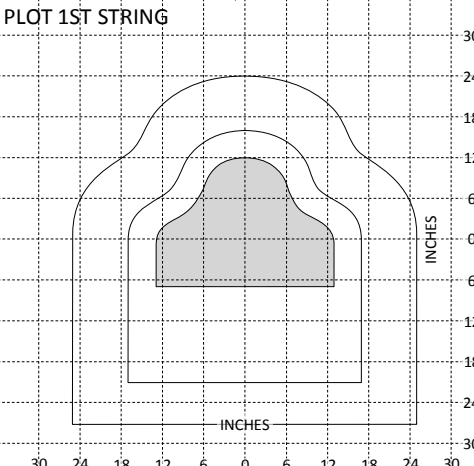
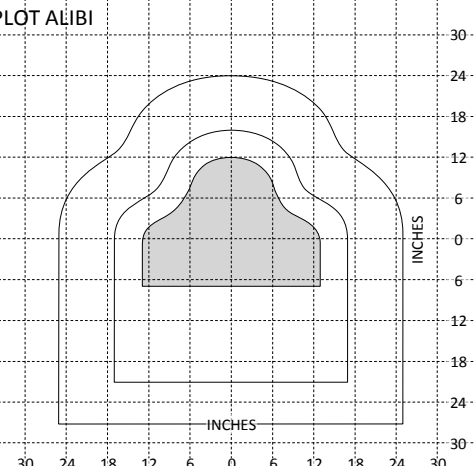
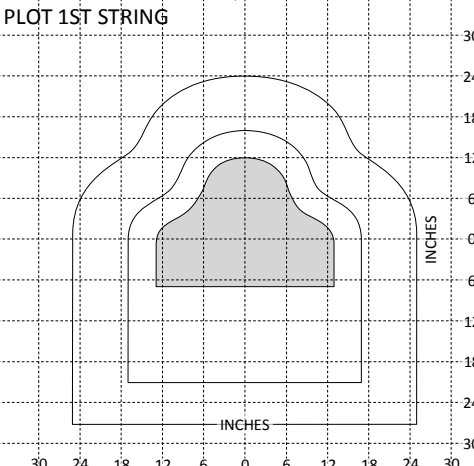
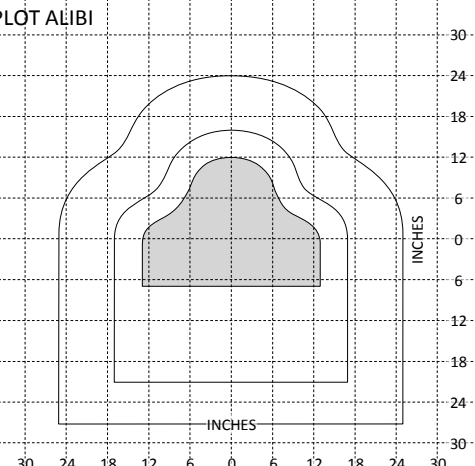
300 YARD RAPID-FIRE PRONE			BEFORE FIRING			DAY THREE EVALUATION																																										
ZERO	+	WIND	=		HOLD																																											
		HOLDS IN INCHES																																														
		<table border="1" style="font-size: small;"> <thead> <tr> <th>VALUE</th> <th colspan="2">5mph</th> <th colspan="2">10mph</th> <th colspan="2">15mph</th> <th colspan="2">20mph</th> <th colspan="2">25mph</th> </tr> <tr> <th></th> <th>M16A4</th> <th>M4</th> <th>M16A4</th> <th>M4</th> <th>M16A4</th> <th>M4</th> <th>M16A4</th> <th>M4</th> <th>M16A4</th> <th>M4</th> </tr> </thead> <tbody> <tr> <td>FULL</td> <td>5</td> <td>6</td> <td>11</td> <td>13</td> <td>16</td> <td>16</td> <td>22</td> <td>25</td> <td>27</td> <td>32</td> </tr> <tr> <td>HALF</td> <td>2</td> <td>3</td> <td>5</td> <td>6</td> <td>8</td> <td>8</td> <td>11</td> <td>12</td> <td>13</td> <td>16</td> </tr> </tbody> </table>	VALUE	5mph		10mph		15mph		20mph		25mph			M16A4	M4	M16A4	M4	M16A4	M4	M16A4	M4	M16A4	M4	FULL	5	6	11	13	16	16	22	25	27	32	HALF	2	3	5	6	8	8	11	12	13	16		
VALUE	5mph		10mph		15mph		20mph		25mph																																							
	M16A4	M4	M16A4	M4	M16A4	M4	M16A4	M4	M16A4	M4																																						
FULL	5	6	11	13	16	16	22	25	27	32																																						
HALF	2	3	5	6	8	8	11	12	13	16																																						
PLOT 1ST STRING	<b>DURING FIRING</b>			PLOT ALIBI																																												
	<b>ALIBI HOLD</b>																																															
	<b>REMARKS</b>																																															
LIGHT <input type="checkbox"/> OVERCAST <input type="checkbox"/> PARTLY CLOUDY <input type="checkbox"/> CLEAR	PRECIP <input type="checkbox"/> DRY <input type="checkbox"/> LT RAIN <input type="checkbox"/> MIST <input type="checkbox"/> HVY RAIN	<b>SIGHT PICTURE ADJUSTMENT (WITHOUT WIND)</b>																																														

300 YARD RAPID-FIRE PRONE			BEFORE FIRING			DAY THREE EVALUATION																																										
ZERO	+	WIND	=		HOLD																																											
		HOLDS IN INCHES																																														
		<table border="1" style="font-size: small;"> <thead> <tr> <th>VALUE</th> <th colspan="2">5mph</th> <th colspan="2">10mph</th> <th colspan="2">15mph</th> <th colspan="2">20mph</th> <th colspan="2">25mph</th> </tr> <tr> <th></th> <th>M16A4</th> <th>M4</th> <th>M16A4</th> <th>M4</th> <th>M16A4</th> <th>M4</th> <th>M16A4</th> <th>M4</th> <th>M16A4</th> <th>M4</th> </tr> </thead> <tbody> <tr> <td>FULL</td> <td>5</td> <td>6</td> <td>11</td> <td>13</td> <td>16</td> <td>16</td> <td>22</td> <td>25</td> <td>27</td> <td>32</td> </tr> <tr> <td>HALF</td> <td>2</td> <td>3</td> <td>5</td> <td>6</td> <td>8</td> <td>8</td> <td>11</td> <td>12</td> <td>13</td> <td>16</td> </tr> </tbody> </table>	VALUE	5mph		10mph		15mph		20mph		25mph			M16A4	M4	M16A4	M4	M16A4	M4	M16A4	M4	M16A4	M4	FULL	5	6	11	13	16	16	22	25	27	32	HALF	2	3	5	6	8	8	11	12	13	16		
VALUE	5mph		10mph		15mph		20mph		25mph																																							
	M16A4	M4	M16A4	M4	M16A4	M4	M16A4	M4	M16A4	M4																																						
FULL	5	6	11	13	16	16	22	25	27	32																																						
HALF	2	3	5	6	8	8	11	12	13	16																																						
PLOT 1ST STRING	<b>DURING FIRING</b>			PLOT ALIBI																																												
	<b>ALIBI HOLD</b>																																															
	<b>REMARKS</b>																																															
LIGHT <input type="checkbox"/> OVERCAST <input type="checkbox"/> PARTLY CLOUDY <input type="checkbox"/> CLEAR	PRECIP <input type="checkbox"/> DRY <input type="checkbox"/> LT RAIN <input type="checkbox"/> MIST <input type="checkbox"/> HVY RAIN	<b>SIGHT PICTURE ADJUSTMENT (WITHOUT WIND)</b>																																														

500 YARD SLOW-FIRE PRONE		BEFORE FIRING		DAY THREE EVALUATION			
ZERO	+	WIND	=	HOLD			
		HOLDS IN INCHES					
		VALUE	5mph	10mph	15mph	20mph	25mph
			M16A4 M4	M16A4 M4	M16A4 M4	M16A4 M4	M16A4 M4
		FULL	17 20	35 40	52 60	69 81	87 101
		HALF	8 10	17 20	26 30	34 40	43 50
WEATHER DATA		PLOT		AFTER FIRING			
LIGHT <input type="checkbox"/> OVERCAST <input type="checkbox"/> PARTLY CLOUDY <input type="checkbox"/> CLEAR		PRECIP <input type="checkbox"/> DRY <input type="checkbox"/> LT RAIN <input type="checkbox"/> MIST <input type="checkbox"/> HVY RAIN			<b>SIGHT PICTURE ADJUSTMENT (WITHOUT WIND)</b> 		
CALL	1	2	3	4	5		
HOLD							
CALL	6	7	8	9	10		
HOLD							
<b>REMARKS</b>							

500 YARD SLOW-FIRE PRONE		BEFORE FIRING		DAY THREE EVALUATION			
ZERO	+	WIND	=	HOLD			
		HOLDS IN INCHES					
		VALUE	5mph	10mph	15mph	20mph	25mph
			M16A4 M4	M16A4 M4	M16A4 M4	M16A4 M4	M16A4 M4
		FULL	17 20	35 40	52 60	69 81	87 101
		HALF	8 10	17 20	26 30	34 40	43 50
WEATHER DATA		PLOT		AFTER FIRING			
LIGHT <input type="checkbox"/> OVERCAST <input type="checkbox"/> PARTLY CLOUDY <input type="checkbox"/> CLEAR		PRECIP <input type="checkbox"/> DRY <input type="checkbox"/> LT RAIN <input type="checkbox"/> MIST <input type="checkbox"/> HVY RAIN			<b>SIGHT PICTURE ADJUSTMENT (WITHOUT WIND)</b> 		
CALL	1	2	3	4	5		
HOLD							
CALL	6	7	8	9	10		
HOLD							
<b>REMARKS</b>							

## TABLE 2

### SHOT DELIVERY

<b>CONTROLLED PAIR</b>	Two shots in quick succession to the torso with a separate sight picture for each shot. A Controlled Pair is an immediate target engagement technique for targets greater than 15 yards.
<b>FAILURE TO STOP</b>	This is a controlled pair to the torso followed by an additional shot to an alternate aiming point ("T-Box" or Pelvic Girdle).
<b>"BOX DRILL"</b>	<p>A method of engaging multiple targets:</p> <ol style="list-style-type: none"> <li>1) Start with the greatest threat and fire a pair to the torso. Utilize the recoil of the last shot and present your weapon to the next target and fire another pair.</li> <li>2) Assess the same target. Then, if required, engage an alternate aim point.</li> <li>3) Utilize the recoil of the last shot and present your weapon to an alternate aim point on the first target. Aim and fire a single shot. Follow through back to the same alternate aim point and then assess both targets.</li> </ol> <p>This is referred to as a box drill due to its square method of shot placement.</p>

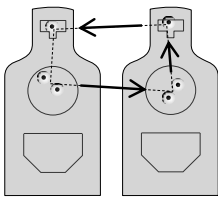

## TABLE 2

### SHOT DELIVERY

<b>CONTROLLED PAIR</b>	Two shots in quick succession to the torso with a separate sight picture for each shot. A Controlled Pair is an immediate target engagement technique for targets greater than 15 yards.
<b>FAILURE TO STOP</b>	This is a controlled pair to the torso followed by an additional shot to an alternate aiming point ("T-Box" or Pelvic Girdle).
<b>"BOX DRILL"</b>	<p>A method of engaging multiple targets:</p> <ol style="list-style-type: none"> <li>1) Start with the greatest threat and fire a pair to the torso. Utilize the recoil of the last shot and present your weapon to the next target and fire another pair.</li> <li>2) Assess the same target. Then, if required, engage an alternate aim point.</li> <li>3) Utilize the recoil of the last shot and present your weapon to an alternate aim point on the first target. Aim and fire a single shot. Follow through back to the same alternate aim point and then assess both targets.</li> </ol> <p>This is referred to as a box drill due to its square method of shot placement.</p>

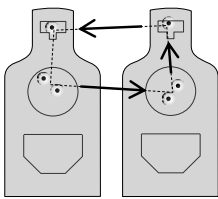

# TABLE 2 TARGETS

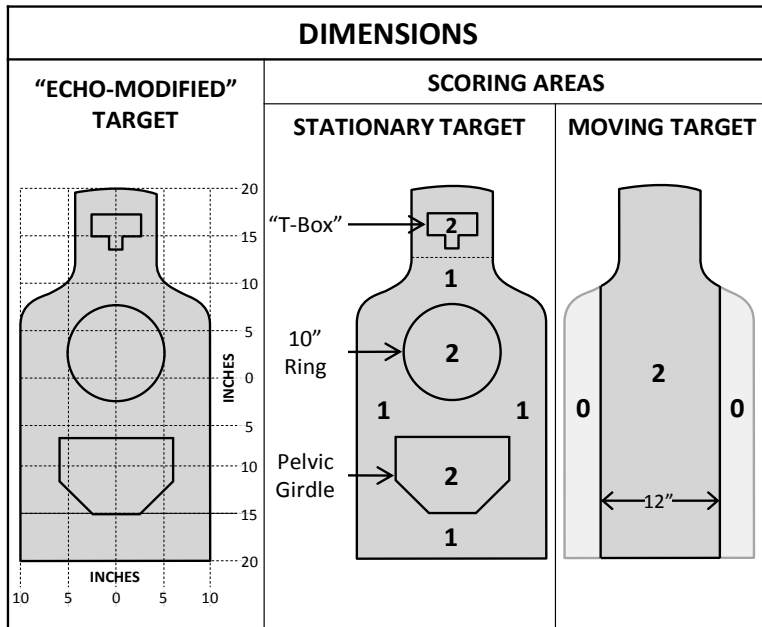





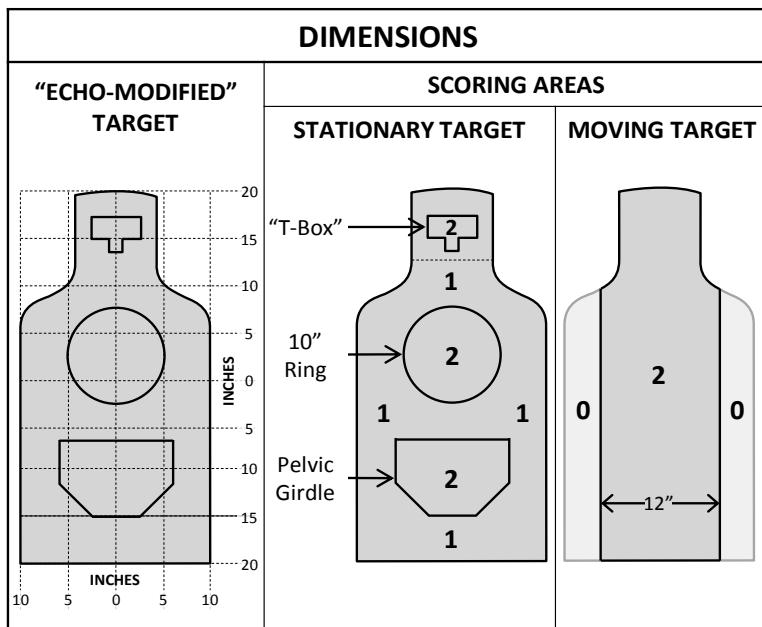



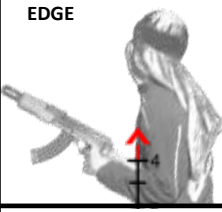

AIMING POINTS	
<b>"T-Box"</b>	A shot placed in the "T-Box" of a human will destroy the brain and cause immediate incapacitation and loss of life.
<b>10" Ring</b>	A shot through the heart or the connecting vascular structure will likely cause the target to bleed to death within 10-30 seconds.
<b>Pelvic Girdle</b>	Destruction of the pelvic bone will likely cause the target to become immobile, which will allow you more space and time for follow on shots.

# TABLE 2 TARGETS



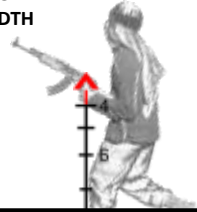



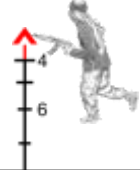





AIMING POINTS	
<b>"T-Box"</b>	A shot placed in the "T-Box" of a human will destroy the brain and cause immediate incapacitation and loss of life.
<b>10" Ring</b>	A shot through the heart or the connecting vascular structure will likely cause the target to bleed to death within 10-30 seconds.
<b>Pelvic Girdle</b>	Destruction of the pelvic bone will likely cause the target to become immobile, which will allow you more space and time for follow on shots.

# MOVING TARGET LEADS

	SLOW WALKING TARGET (APPROX. 2 MPH)	FAST WALKING TARGET (APPROX. 4 MPH)	JOGGING TARGET (APPROX. 6 MPH)	RUNNING TARGET (APPROX. 10 MPH)
50 M	NO LEAD 	NO LEAD 	LEADING EDGE 	1 BODY WIDTH 
100 M	NO LEAD 	LEADING EDGE 	1 BODY WIDTH 	1½ BODY WIDTHS 
200 M	LEADING EDGE 	1 BODY WIDTH 	2 BODY WIDTHS 	3 BODY WIDTHS 

# MOVING TARGET LEADS

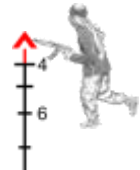
	SLOW WALKING TARGET (APPROX. 2 MPH)	FAST WALKING TARGET (APPROX. 4 MPH)	JOGGING TARGET (APPROX. 6 MPH)	RUNNING TARGET (APPROX. 10 MPH)
50 M	NO LEAD 	NO LEAD 	LEADING EDGE 	1 BODY WIDTH 
100 M	NO LEAD 	LEADING EDGE 	1 BODY WIDTH 	1½ BODY WIDTHS 
200 M	LEADING EDGE 	1 BODY WIDTH 	2 BODY WIDTHS 	3 BODY WIDTHS 

## TABLE 2 COURSE OF FIRE TRAINING (DAY 1)

STAGE	DRILL	RANGE	POSITION	RNDS / DRILL	TIME (SEC)	ITERATIONS	TOTAL RNDS
BZO		300	PRONE	10	N/A	1	10
POSITION REFINEMENT		25/50	Standing	24	N/A	1	24
2) PRESENTATION	Head shot	25/50	Standing	1	3	2	2
	Controlled Pair	25/50	Standing	2	4	2	4
	Failure (alternate aiming point)	25/50	Standing	3	5	2	6
3) POSITION CHANGE	(2) Controlled Pairs	25/50	Standing to Kneeling	2	5	2	4
	(2) Controlled Pairs	25/50	Standing & Kneeling	4	7	2	8
	Failure (alternate aiming point)	25/50	Standing to Kneeling	3	8	2	6
4) MULTIPLE TARGETS WITH POSITION CHANGE	(2) Controlled Pairs	25/50	Standing to Kneeling	4	6	1	4
	(2) Controlled Pairs	25/50	Standing & Kneeling	4	9	2	8
	(2) Failure (alternate aiming point)	25/50	Standing to Kneeling	6	10	2	12
5) SPEED RELOADS	(2) Controlled Pairs	25/50	Standing & Kneeling	4	10	5	20
6) MOVING TARGET ENGAGEMENT	Movers Right	100/200	Standing to Kneeling	2	10	3	6
	Movers Left	100/200	Standing to Kneeling	2	10	3	6

54

## TABLE 2 COURSE OF FIRE TRAINING (DAY 1)

STAGE	DRILL	RANGE	POSITION	RNDS / DRILL	TIME (SEC)	ITERATIONS	TOTAL RNDS
BZO		300	PRONE	10	N/A	1	10
POSITION REFINEMENT		25/50	Standing	24	N/A	1	24
2) PRESENTATION	Head shot	25/50	Standing	1	3	2	2
	Controlled Pair	25/50	Standing	2	4	2	4
	Failure (alternate aiming point)	25/50	Standing	3	5	2	6
3) POSITION CHANGE	(2) Controlled Pairs	25/50	Standing to Kneeling	2	5	2	4
	(2) Controlled Pairs	25/50	Standing & Kneeling	4	7	2	8
	Failure (alternate aiming point)	25/50	Standing to Kneeling	3	8	2	6
4) MULTIPLE TARGETS WITH POSITION CHANGE	(2) Controlled Pairs	25/50	Standing to Kneeling	4	6	1	4
	(2) Controlled Pairs	25/50	Standing & Kneeling	4	9	2	8
	(2) Failure (alternate aiming point)	25/50	Standing to Kneeling	6	10	2	12
5) SPEED RELOADS	(2) Controlled Pairs	25/50	Standing & Kneeling	4	10	5	20
6) MOVING TARGET ENGAGEMENT	Movers Right	100/200	Standing to Kneeling	2	10	3	6
	Movers Left	100/200	Standing to Kneeling	2	10	3	6

54



## TABLE 2 COURSE OF FIRE PRE-EVALUATION & EVALUATION (DAY 2)

STAGE	DRILL	RANGE	POSITION	RNDS / DRILL	TIME (SEC)	ITERATIONS	TOTAL RNDS
1) PRESENTATION	Head shot	25/50	Standing	1	3	2	2
	Controlled Pair	25/50	Standing	2	4	1	2
	Failure (alternate aiming point)	25/50	Standing	3	5	1	3
2) POSITION CHANGE	Controlled Pairs	25/50	Standing & Kneeling	4	7	1	4
	Failure (alternate aiming point)	25/50	Standing to Kneeling	3	8	1	3
3) MULTIPLE TARGETS WITH POSITION CHANGE	(2) Controlled Pairs	25/50	Standing to Kneeling	4	6	1	4
	(2) Controlled Pairs	25/50	Standing & Kneeling	4	9	2	8
	(2) Failure (alternate aiming point)	25/50	Standing to Kneeling	6	10	2	12
4) SPEED RELOADS	(2) Controlled Pairs	25/50	Standing & Kneeling	4	10	1	4
5) MOVING TARGET ENGAGEMENT	Movers Right	100/200	Standing to Kneeling	2	10	2	4
	Movers Left	100/200	Standing to Kneeling	2	10	2	4

## TABLE 2 COURSE OF FIRE PRE-EVALUATION & EVALUATION (DAY 2)

STAGE	DRILL	RANGE	POSITION	RNDS / DRILL	TIME (SEC)	ITERATIONS	TOTAL RNDS
1) PRESENTATION	Head shot	25/50	Standing	1	3	2	2
	Controlled Pair	25/50	Standing	2	4	1	2
	Failure (alternate aiming point)	25/50	Standing	3	5	1	3
2) POSITION CHANGE	Controlled Pairs	25/50	Standing & Kneeling	4	7	1	4
	Failure (alternate aiming point)	25/50	Standing to Kneeling	3	8	1	3
3) MULTIPLE TARGETS WITH POSITION CHANGE	(2) Controlled Pairs	25/50	Standing to Kneeling	4	6	1	4
	(2) Controlled Pairs	25/50	Standing & Kneeling	4	9	2	8
	(2) Failure (alternate aiming point)	25/50	Standing to Kneeling	6	10	2	12
4) SPEED RELOADS	(2) Controlled Pairs	25/50	Standing & Kneeling	4	10	1	4
5) MOVING TARGET ENGAGEMENT	Movers Right	100/200	Standing to Kneeling	2	10	2	4
	Movers Left	100/200	Standing to Kneeling	2	10	2	4

ZERO + WIND = HOLD

HOLDS IN INCHES

VALUE	5mph M16A4 M4	10mph M16A4 M4	15mph M16A4 M4	20mph M16A4 M4	25mph M16A4 M4					
FULL	5	6	11	13	16	16	22	25	27	32
HALF	2	3	5	6	8	8	11	12	13	16

PLOT

RCO CLICKS

INCHES

LIGHT

OVERCAST

PARTLY CLOUDY

CLEAR

PRECIP

DRY

MIST

LT RAIN

HVY RAIN

**SIGHT PICTURE ADJUSTMENT (WITHOUT WIND)**

ZERO + WIND = HOLD

HOLDS IN INCHES

VALUE	5mph M16A4 M4	10mph M16A4 M4	15mph M16A4 M4	20mph M16A4 M4	25mph M16A4 M4					
FULL	5	6	11	13	16	16	22	25	27	32
HALF	2	3	5	6	8	8	11	12	13	16

PLOT

RCO CLICKS

INCHES

LIGHT

OVERCAST

PARTLY CLOUDY

CLEAR

PRECIP

DRY

MIST

LT RAIN

HVY RAIN

**SIGHT PICTURE ADJUSTMENT (WITHOUT WIND)**

**TABLE 2 - STATIONARY**

BEFORE FIRING HOLD		AFTER FIRING CORRECTED HOLD		
	<p><u>Remarks</u></p>		<p><u>Remarks</u></p>	
<b>PRESENTATION</b>	<b>POSITION CHANGE</b>	<b>MULTIPLE TARGET WITH POSITION CHANGE</b>		<b>SPEED RELOAD</b>

**TABLE 2 - STATIONARY**

BEFORE FIRING HOLD		AFTER FIRING CORRECTED HOLD		
	<p><u>Remarks</u></p>		<p><u>Remarks</u></p>	
<b>PRESENTATION</b>	<b>POSITION CHANGE</b>	<b>MULTIPLE TARGET WITH POSITION CHANGE</b>		<b>SPEED RELOAD</b>

**TABLE 2 - MOVING**

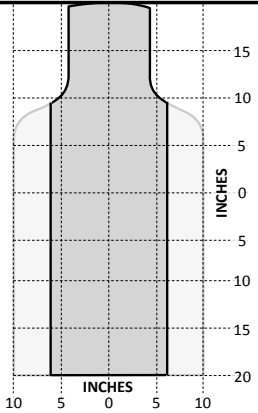
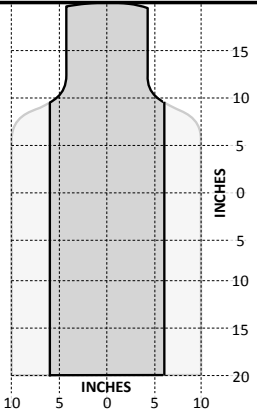
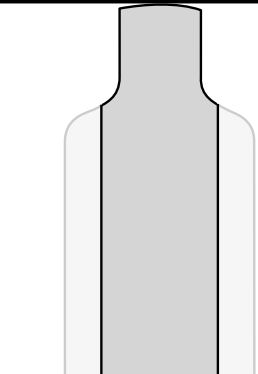
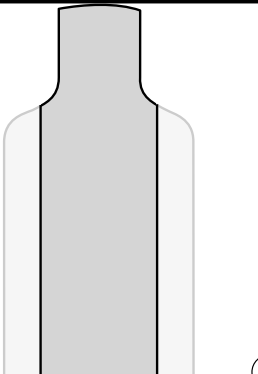
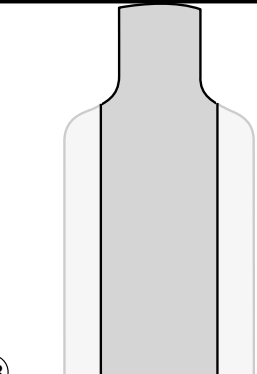
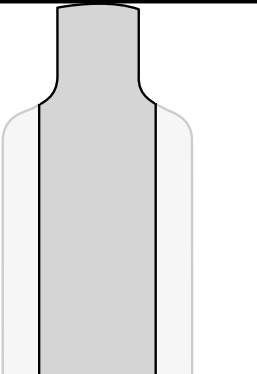
BEFORE FIRING HOLD		AFTER FIRING CORRECTED HOLD	
		<u>Remarks</u>	
		<u>Remarks</u>	
OR		OR	
			
			

**TABLE 2 - MOVING**

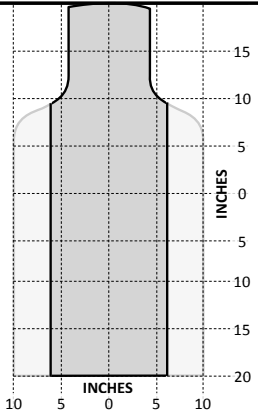
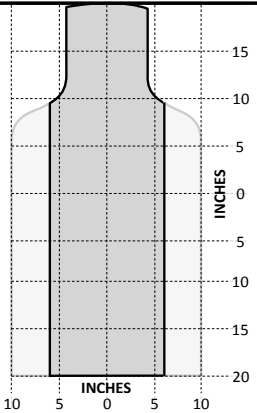
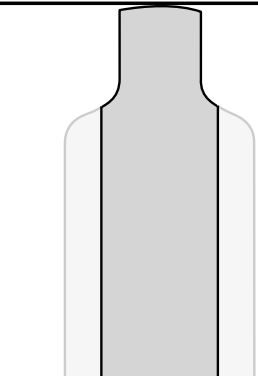
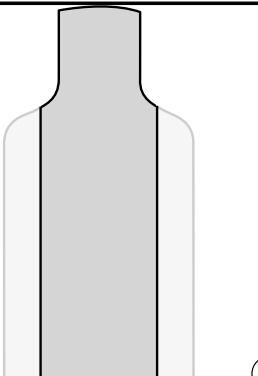
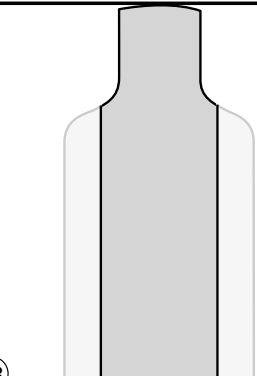
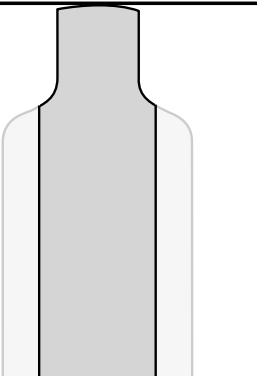
BEFORE FIRING HOLD		AFTER FIRING CORRECTED HOLD	
		<u>Remarks</u>	
		<u>Remarks</u>	
OR		OR	
			
			

## SCORING

	Points possible	Qualification
Table 1	250	$\geq 190$ points
Table 2	100	$\geq 60$ points

### Aggregate Score



305-350 = EXPERT

280-304 = SHARPSHOOTER

250-279 = MARKSMAN

## SCORING

	Points possible	Qualification
Table 1	250	$\geq 190$ points
Table 2	100	$\geq 60$ points

### Aggregate Score



305-350 = EXPERT

280-304 = SHARPSHOOTER

250-279 = MARKSMAN

# AIMING

## CORRECT SIGHT ALIGNMENT

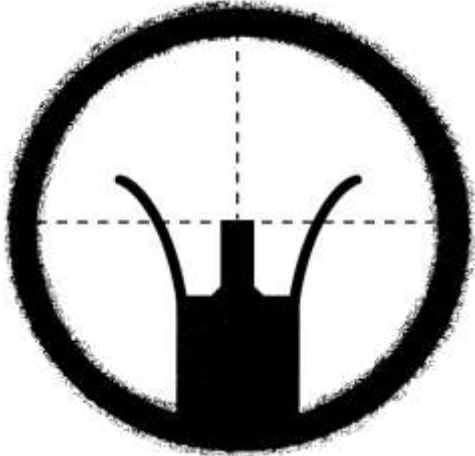

**CORRECT SIGHT ALIGNMENT**  
The tip of the front sight post centered both vertically and horizontally in the rear sight aperture.

## CORRECT SIGHT PICTURE



**CORRECT SIGHT PICTURE**  
The placement of the tip of the front sight in the center of the target while maintaining correct sight alignment.

# AIMING

## CORRECT SIGHT ALIGNMENT

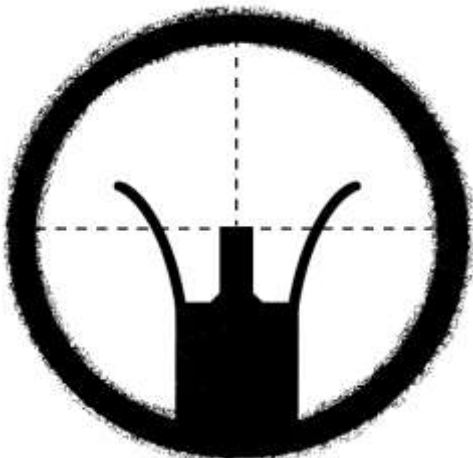

**CORRECT SIGHT ALIGNMENT**  
The tip of the front sight post centered both vertically and horizontally in the rear sight aperture.

## CORRECT SIGHT PICTURE



**CORRECT SIGHT PICTURE**  
The placement of the tip of the front sight in the center of the target while maintaining correct sight alignment.

# BUIS WINDAGE/ELEVATION RULES AND ADJUSTMENTS (clicks) M16A4

Wind speed is determined by the angle of the flag. The different speeds at each angle can be approximated based on how fast the flag flutters at each angle.

WIND VALUE	5 MPH		10 MPH		15 MPH		20 MPH		25 MPH	
	FULL	HALF	FULL	HALF	FULL	HALF	FULL	HALF	FULL	HALF
200	2	1	3	1	5	2	6	3	8	4
300	3	1	6	3	10	5	13	6	16	8
500	6	3	12	6	18	9	24	12	30	15

One (1) click adjustment moves strike of round at 100 yards/meters:

Front Sight Post	1 3/8 INCHES
BUIS Elevation Drum	5/8 INCH
BUIS Windage Knob	1/2 INCH



BUIS Windage Knob



Front Sight Post

# BUIS WINDAGE/ELEVATION RULES AND ADJUSTMENTS (clicks) M16A4

Wind speed is determined by the angle of the flag. The different speeds at each angle can be approximated based on how fast the flag flutters at each angle.

WIND VALUE	5 MPH		10 MPH		15 MPH		20 MPH		25 MPH	
	FULL	HALF	FULL	HALF	FULL	HALF	FULL	HALF	FULL	HALF
200	2	1	3	1	5	2	6	3	8	4
300	3	1	6	3	10	5	13	6	16	8
500	6	3	12	6	18	9	24	12	30	15

One (1) click adjustment moves strike of round at 100 yards/meters:

Front Sight Post	1 3/8 INCHES
BUIS Elevation Drum	5/8 INCH
BUIS Windage Knob	1/2 INCH



BUIS Windage Knob

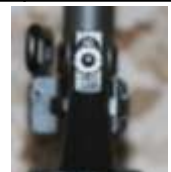

Front Sight Post

# BUIS WINDAGE/ELEVATION RULES AND ADJUSTMENTS (clicks) M4

Wind speed is determined by the angle of the flag. The different speeds at each angle can be approximated based on how fast the flag flutters at each angle.

WIND VALUE	5 MPH		10 MPH		15 MPH		20 MPH		25 MPH	
	FULL	HALF	FULL	HALF	FULL	HALF	FULL	HALF	FULL	HALF
200	1	1	2	1	3	1	4	2	5	2
300	2	1	4	2	7	3	9	4	11	5
500	4	2	8	4	12	6	16	8	20	10

One (1) click adjustment moves strike of round at 100 yards/meters:

Front Sight Post	1 7/8 INCHES
BUIS Elevation Drum	3/4 INCH
BUIS Windage Knob	3/4 INCH



BUIS Windage Knob



Front Sight Post

# BUIS WINDAGE/ELEVATION RULES AND ADJUSTMENTS (clicks) M4

Wind speed is determined by the angle of the flag. The different speeds at each angle can be approximated based on how fast the flag flutters at each angle.

WIND VALUE	5 MPH		10 MPH		15 MPH		20 MPH		25 MPH	
	FULL	HALF	FULL	HALF	FULL	HALF	FULL	HALF	FULL	HALF
200	1	1	2	1	3	1	4	2	5	2
300	2	1	4	2	7	3	9	4	11	5
500	4	2	8	4	12	6	16	8	20	10

One (1) click adjustment moves strike of round at 100 yards/meters:

Front Sight Post	1 7/8 INCHES
BUIS Elevation Drum	3/4 INCH
BUIS Windage Knob	3/4 INCH



BUIS Windage Knob



Front Sight Post



# 36 YARD FIELD EXPEDIENT BZO

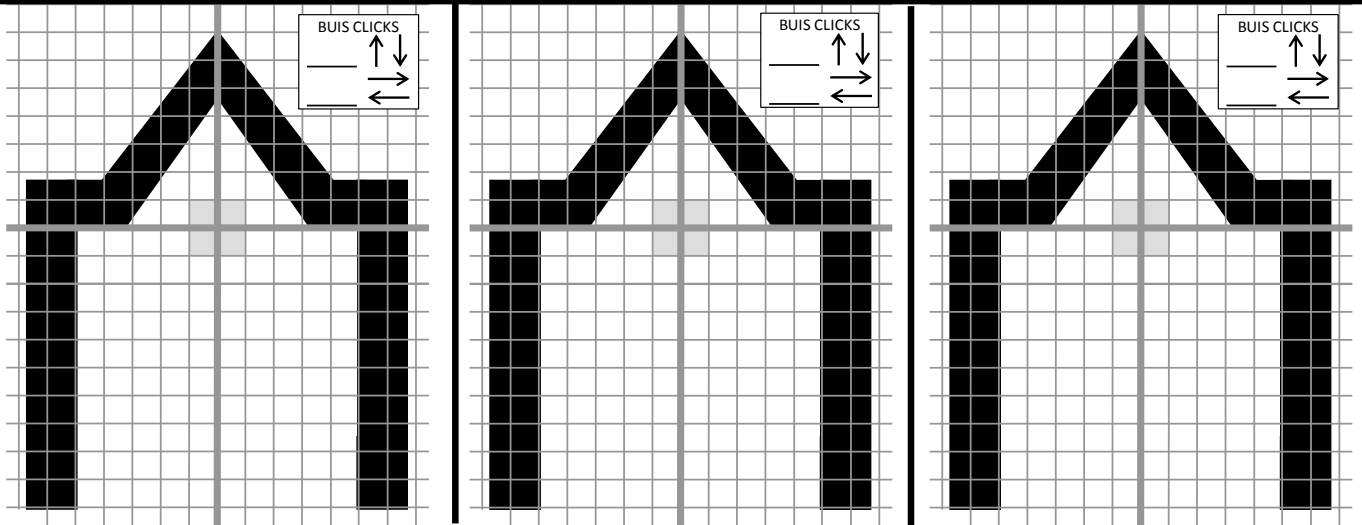

Two major objectives for the exercise:

1. To determine if the weapon can hold a group or is mechanically deficient.
2. To determine if the shooter can apply marksmanship fundamentals.

The steps for grouping are:

1. The shooter fires five rounds at the center target.
2. The coach measures the size of the group to determine if the shooter can hold a nine minute of angle group. The shooter fires the next five rounds on the left target.
3. Repeat step two. The shooter fires the last five rounds on the right target.
4. Repeat step two. If the weapon holds a nine minute of angle group the shooter is done firing. If not, range personnel will fire the weapon. If the weapon does not hold a group, issue the shooter a new weapon and repeat the exercise.

Each square = 1/2 inch

ELEVATION:

RCO - 9 clicks = 1 in  
 M16A4 (BUIS) - 1 click = 1 1/2 in  
 M16A4 (FSP) - 1 click = 4 1/8 in

WINDAGE:

RCO - 9 clicks = 1 in  
 M16A4 - (BUIS) - 3 clicks = 1/2 in

# 36 YARD FIELD EXPEDIENT BZO

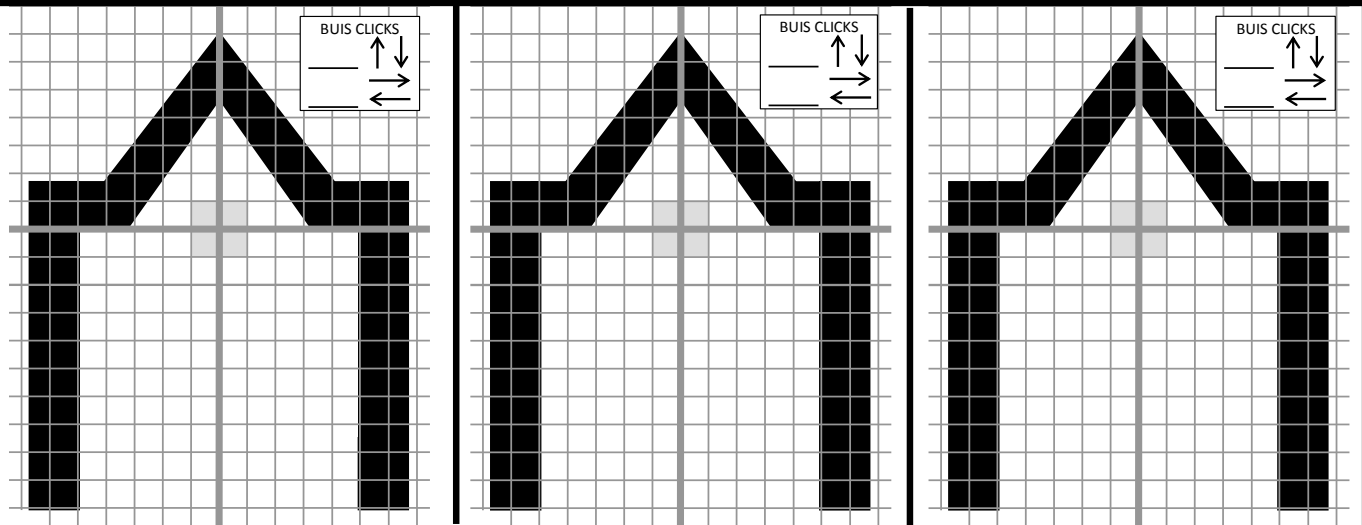

Two major objectives for the exercise:

1. To determine if the weapon can hold a group or is mechanically deficient.
2. To determine if the shooter can apply marksmanship fundamentals.

The steps for grouping are:

1. The shooter fires five rounds at the center target.
2. The coach measures the size of the group to determine if the shooter can hold a nine minute of angle group. The shooter fires the next five rounds on the left target.
3. Repeat step two. The shooter fires the last five rounds on the right target.
4. Repeat step two. If the weapon holds a nine minute of angle group the shooter is done firing. If not, range personnel will fire the weapon. If the weapon does not hold a group, issue the shooter a new weapon and repeat the exercise.

Each square = 1/2 inch

ELEVATION:

RCO - 9 clicks = 1 in  
 M16A4 (BUIS) - 1 click = 1 1/2 in  
 M16A4 (FSP) - 1 click = 4 1/8 in

WINDAGE:







RCO - 9 clicks = 1 in  
 M16A4 - (BUIS) - 3 clicks = 1/2 in



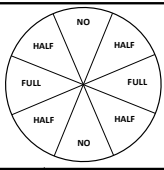



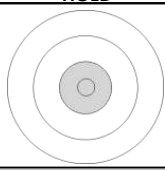
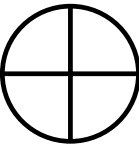
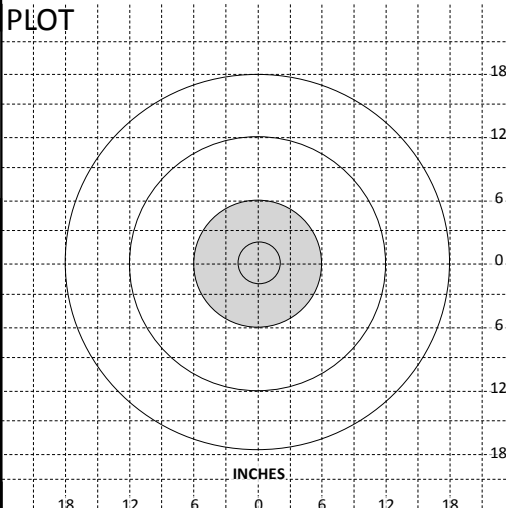

## DIVISION MATCH COURSE OF FIRE

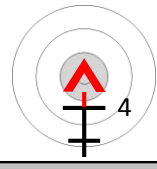
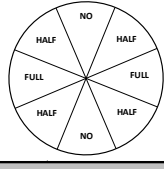
STAGE	ROUNDS	POSITION	TIME (SEC)
200 YARD SLOW FIRE	20	STANDING	20 MIN
200 YARD RAPID FIRE	10	STANDING TO SITTING	60 SEC
300 YARD RAPID FIRE	10	STANDING TO PRONE	70 SEC
500 YARD SLOW FIRE	20	PRONE	20 MIN

## DIVISION MATCH COURSE OF FIRE



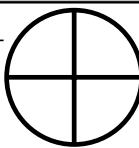
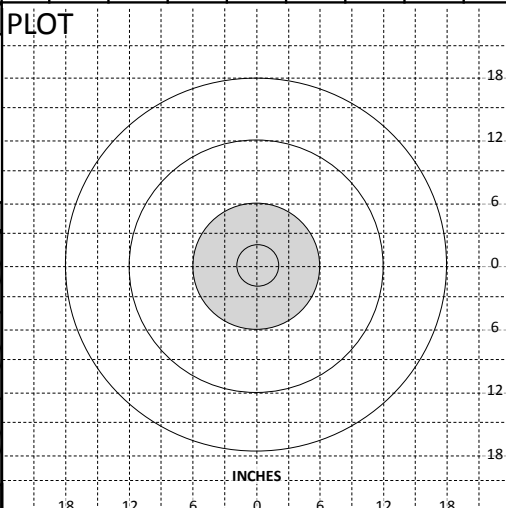

STAGE	ROUNDS	POSITION	TIME (SEC)
200 YARD SLOW FIRE	20	STANDING	20 MIN
200 YARD RAPID FIRE	10	STANDING TO SITTING	60 SEC
300 YARD RAPID FIRE	10	STANDING TO PRONE	70 SEC
500 YARD SLOW FIRE	20	PRONE	20 MIN



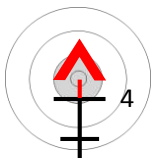
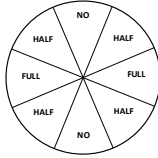

200 YARD SLOW-FIRE				BEFORE FIRING										DAY ONE																																							
ZERO				+ WIND =										HOLD																																							
				HOLDS IN INCHES																																																	
				<table border="1" style="font-size: small;"> <thead> <tr> <th>VALUE</th> <th colspan="2">5mph</th> <th colspan="2">10mph</th> <th colspan="2">15mph</th> <th colspan="2">20mph</th> <th colspan="2">25mph</th> </tr> <tr> <td></td> <td>M16A4</td> <td>M4</td> <td>M16A4</td> <td>M4</td> <td>M16A4</td> <td>M4</td> <td>M16A4</td> <td>M4</td> <td>M16A4</td> <td>M4</td> </tr> </thead> <tbody> <tr> <td>FULL</td> <td>2</td> <td>3</td> <td>5</td> <td>5</td> <td>7</td> <td>8</td> <td>9</td> <td>10</td> <td>11</td> <td>19</td> </tr> <tr> <td>HALF</td> <td>1</td> <td>1</td> <td>2</td> <td>2</td> <td>3</td> <td>4</td> <td>4</td> <td>5</td> <td>5</td> <td>9</td> </tr> </tbody> </table>		VALUE	5mph		10mph		15mph		20mph		25mph			M16A4	M4	M16A4	M4	M16A4	M4	M16A4	M4	M16A4	M4	FULL	2	3	5	5	7	8	9	10	11	19	HALF	1	1	2	2	3	4	4	5	5	9				
VALUE	5mph		10mph		15mph		20mph		25mph																																												
	M16A4	M4	M16A4	M4	M16A4	M4	M16A4	M4	M16A4	M4																																											
FULL	2	3	5	5	7	8	9	10	11	19																																											
HALF	1	1	2	2	3	4	4	5	5	9																																											
<b>WEATHER DATA</b>				<b>PLOT</b>										<b>AFTER FIRING</b>																																							
LIGHT <input type="checkbox"/> OVERCAST <input type="checkbox"/> PARTLY CLOUDY <input type="checkbox"/> CLEAR				PRECIP <input type="checkbox"/> DRY <input type="checkbox"/> LT RAIN <input type="checkbox"/> MIST <input type="checkbox"/> HVY RAIN												<b>SIGHT PICTURE ADJUSTMENT (WITHOUT WIND)</b>																																					
<b>DURING FIRING</b>																<b>REMARKS</b>																																					
1	2	3	4	5	6	7	8	9	10	11	12	13	14	15	16	17	18	19	20																																		

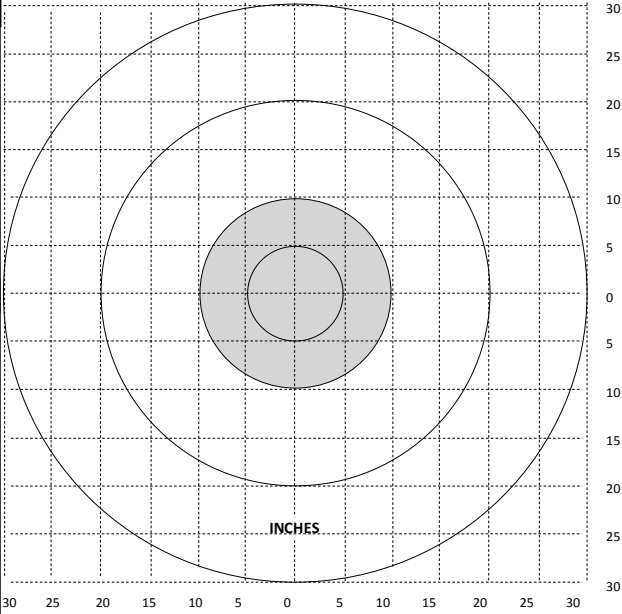
200 YARD SLOW-FIRE				BEFORE FIRING										DAY ONE																																							
ZERO				+ WIND =										HOLD																																							
				HOLDS IN INCHES																																																	
				<table border="1" style="font-size: small;"> <thead> <tr> <th>VALUE</th> <th colspan="2">5mph</th> <th colspan="2">10mph</th> <th colspan="2">15mph</th> <th colspan="2">20mph</th> <th colspan="2">25mph</th> </tr> <tr> <td></td> <td>M16A4</td> <td>M4</td> <td>M16A4</td> <td>M4</td> <td>M16A4</td> <td>M4</td> <td>M16A4</td> <td>M4</td> <td>M16A4</td> <td>M4</td> </tr> </thead> <tbody> <tr> <td>FULL</td> <td>2</td> <td>3</td> <td>5</td> <td>5</td> <td>7</td> <td>8</td> <td>9</td> <td>10</td> <td>11</td> <td>19</td> </tr> <tr> <td>HALF</td> <td>1</td> <td>1</td> <td>2</td> <td>2</td> <td>3</td> <td>4</td> <td>4</td> <td>5</td> <td>5</td> <td>9</td> </tr> </tbody> </table>		VALUE	5mph		10mph		15mph		20mph		25mph			M16A4	M4	M16A4	M4	M16A4	M4	M16A4	M4	M16A4	M4	FULL	2	3	5	5	7	8	9	10	11	19	HALF	1	1	2	2	3	4	4	5	5	9				
VALUE	5mph		10mph		15mph		20mph		25mph																																												
	M16A4	M4	M16A4	M4	M16A4	M4	M16A4	M4	M16A4	M4																																											
FULL	2	3	5	5	7	8	9	10	11	19																																											
HALF	1	1	2	2	3	4	4	5	5	9																																											
<b>WEATHER DATA</b>				<b>PLOT</b>										<b>AFTER FIRING</b>																																							
LIGHT <input type="checkbox"/> OVERCAST <input type="checkbox"/> PARTLY CLOUDY <input type="checkbox"/> CLEAR				PRECIP <input type="checkbox"/> DRY <input type="checkbox"/> LT RAIN <input type="checkbox"/> MIST <input type="checkbox"/> HVY RAIN												<b>SIGHT PICTURE ADJUSTMENT (WITHOUT WIND)</b>																																					
<b>DURING FIRING</b>																<b>REMARKS</b>																																					
1	2	3	4	5	6	7	8	9	10	11	12	13	14	15	16	17	18	19	20																																		

200 YARD RAPID-FIRE		BEFORE FIRING										DAY ONE		
ZERO		+ WIND =										HOLD		
		HOLDS IN INCHES												
		5mph		10mph		15mph		20mph		25mph				
		M16A4	M4	M16A4	M4	M16A4	M4	M16A4	M4	M16A4	M4			
		FULL	2	3	5	5	7	8	9	10	11	19		
		HALF	1	1	2	2	3	4	4	5	5	9		
WEATHER DATA												REMARKS		
LIGHT <input type="checkbox"/> OVERCAST <input type="checkbox"/> PARTLY CLOUDY <input type="checkbox"/> CLEAR <input type="checkbox"/> DRY <input type="checkbox"/> LT RAIN <input type="checkbox"/> MIST <input type="checkbox"/> HVY RAIN														
AFTER FIRING														

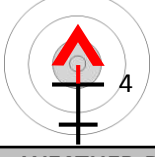
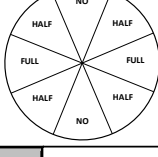
200 YARD RAPID-FIRE		BEFORE FIRING										DAY ONE		
ZERO		+ WIND =										HOLD		
		HOLDS IN INCHES												
		5mph		10mph		15mph		20mph		25mph				
		M16A4	M4	M16A4	M4	M16A4	M4	M16A4	M4	M16A4	M4			
		FULL	2	3	5	5	7	8	9	10	11	19		
		HALF	1	1	2	2	3	4	4	5	5	9		
WEATHER DATA												REMARKS		
LIGHT <input type="checkbox"/> OVERCAST <input type="checkbox"/> PARTLY CLOUDY <input type="checkbox"/> CLEAR <input type="checkbox"/> DRY <input type="checkbox"/> LT RAIN <input type="checkbox"/> MIST <input type="checkbox"/> HVY RAIN														
AFTER FIRING														

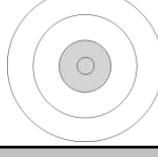
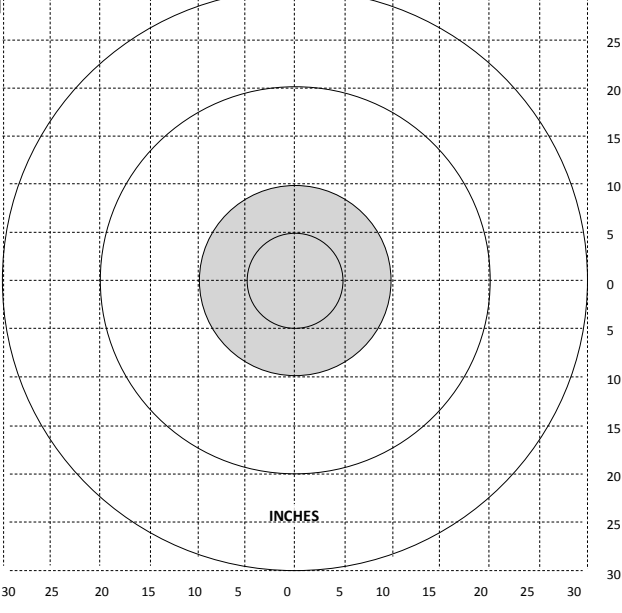
300 YARD RAPID-FIRE		BEFORE FIRING										DAY ONE		
ZERO		+ WIND =										HOLD		
		HOLDS IN INCHES 												
		VALUE	5mph		10mph		15mph		20mph		25mph			
			M16A4	M4	M16A4	M4	M16A4	M4	M16A4	M4	M16A4	M4		
		FULL	5	6	11	13	16	18	22	25	27	32		
		HALF	2	3	5	6	8	9	11	12	13	16		
WEATHER DATA												REMARKS		
LIGHT <input type="checkbox"/> OVERCAST <input type="checkbox"/> PARTLY CLOUDY <input type="checkbox"/> CLEAR <input type="checkbox"/> DRY <input type="checkbox"/> LT RAIN <input type="checkbox"/> MIST <input type="checkbox"/> HVY RAIN												<div style="border: 1px solid black; height: 100%; width: 100%;"></div>		
AFTER FIRING														
														

300 YARD RAPID-FIRE		BEFORE FIRING										DAY ONE		
ZERO		+ WIND =										HOLD		
		HOLDS IN INCHES 												
		VALUE	5mph		10mph		15mph		20mph		25mph			
			M16A4	M4	M16A4	M4	M16A4	M4	M16A4	M4	M16A4	M4		
		FULL	5	6	11	13	16	18	22	25	27	32		
		HALF	2	3	5	6	8	9	11	12	13	16		
WEATHER DATA												REMARKS		
LIGHT <input type="checkbox"/> OVERCAST <input type="checkbox"/> PARTLY CLOUDY <input type="checkbox"/> CLEAR <input type="checkbox"/> DRY <input type="checkbox"/> LT RAIN <input type="checkbox"/> MIST <input type="checkbox"/> HVY RAIN												<div style="border: 1px solid black; height: 100%; width: 100%;"></div>		
AFTER FIRING														
														

**500 YARD SLOW-FIRE** **BEFORE FIRING** **DAY ONE**

ZERO + WIND = **HOLD**

HOLDS IN INCHES

VALUE	5mph		10mph		15mph		20mph		25mph	
	M16A4	M4	M16A4	M4	M16A4	M4	M16A4	M4	M16A4	M4
FULL	17	20	35	40	52	60	69	81	87	101
HALF	8	10	17	20	26	30	34	40	43	50

**WEATHER DATA**

LIGHT  OVERCAST  PARTLY CLOUDY  CLEAR

PRECIP  DRY  LT RAIN  MIST  HVY RAIN

**DURING FIRING**

1	2	3	4
5	6	7	8
9	10	11	12
13	14	15	16
17	18	19	20

**AFTER FIRING**

**REMARKS**

**500 YARD SLOW-FIRE** **BEFORE FIRING** **DAY ONE**

ZERO + WIND = **HOLD**

HOLDS IN INCHES

VALUE	5mph		10mph		15mph		20mph		25mph	
	M16A4	M4	M16A4	M4	M16A4	M4	M16A4	M4	M16A4	M4
FULL	17	20	35	40	52	60	69	81	87	101
HALF	8	10	17	20	26	30	34	40	43	50

**WEATHER DATA**

LIGHT  OVERCAST  PARTLY CLOUDY  CLEAR



PRECIP  DRY  LT RAIN  MIST  HVY RAIN



**DURING FIRING**

1	2	3	4
5	6	7	8
9	10	11	12
13	14	15	16
17	18	19	20

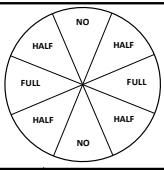
**AFTER FIRING**

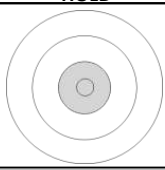
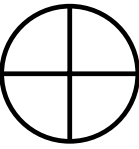
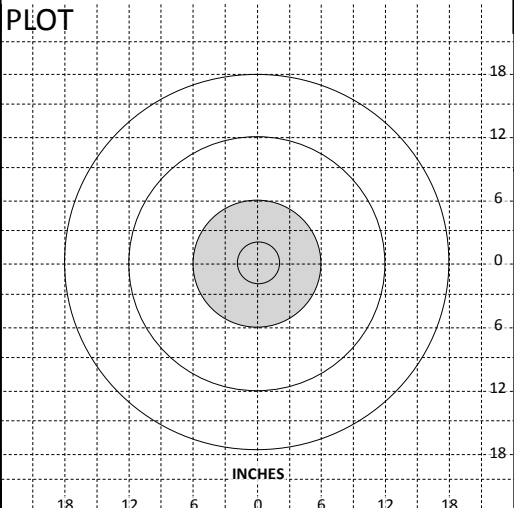
**REMARKS**

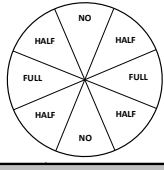
200 YARD SLOW-FIRE				BEFORE FIRING										DAY TWO																																					
ZERO				+ WIND =										HOLD																																					
				HOLDS IN INCHES 																																															
				<table border="1" style="font-size: small;"> <thead> <tr> <th>VALUE</th> <th colspan="2">5mph</th> <th colspan="2">10mph</th> <th colspan="2">15mph</th> <th colspan="2">20mph</th> <th colspan="2">25mph</th> </tr> <tr> <td></td> <td>M16A4</td> <td>M4</td> <td>M16A4</td> <td>M4</td> <td>M16A4</td> <td>M4</td> <td>M16A4</td> <td>M4</td> <td>M16A4</td> <td>M4</td> </tr> </thead> <tbody> <tr> <td>FULL</td> <td>2</td> <td>3</td> <td>5</td> <td>5</td> <td>7</td> <td>8</td> <td>9</td> <td>10</td> <td>11</td> <td>19</td> </tr> <tr> <td>HALF</td> <td>1</td> <td>1</td> <td>2</td> <td>2</td> <td>3</td> <td>4</td> <td>4</td> <td>5</td> <td>5</td> <td>9</td> </tr> </tbody> </table>		VALUE	5mph		10mph		15mph		20mph		25mph			M16A4	M4	M16A4	M4	M16A4	M4	M16A4	M4	M16A4	M4	FULL	2	3	5	5	7	8	9	10	11	19	HALF	1	1	2	2	3	4	4	5	5	9		
VALUE	5mph		10mph		15mph		20mph		25mph																																										
	M16A4	M4	M16A4	M4	M16A4	M4	M16A4	M4	M16A4	M4																																									
FULL	2	3	5	5	7	8	9	10	11	19																																									
HALF	1	1	2	2	3	4	4	5	5	9																																									
<b>WEATHER DATA</b>				<b>PLOT</b>										<b>AFTER FIRING</b>																																					
LIGHT <input type="checkbox"/> OVERCAST <input type="checkbox"/> PARTLY CLOUDY <input type="checkbox"/> CLEAR				PRECIP <input type="checkbox"/> DRY <input type="checkbox"/> LT RAIN <input type="checkbox"/> MIST <input type="checkbox"/> HVY RAIN												<b>SIGHT PICTURE ADJUSTMENT (WITHOUT WIND)</b>																																			
<b>DURING FIRING</b>																<b>REMARKS</b>																																			
1	2	3	4	5	6	7	8	9	10	11	12	13	14	15	16	17	18	19	20																																

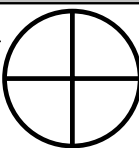
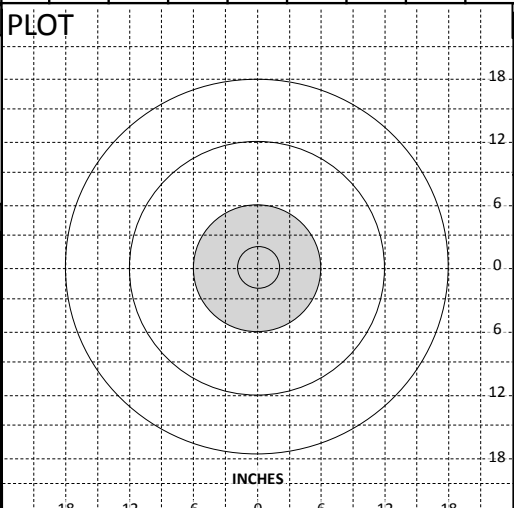
200 YARD SLOW-FIRE				BEFORE FIRING										DAY TWO																																					
ZERO				+ WIND =										HOLD																																					
				HOLDS IN INCHES 																																															
				<table border="1" style="font-size: small;"> <thead> <tr> <th>VALUE</th> <th colspan="2">5mph</th> <th colspan="2">10mph</th> <th colspan="2">15mph</th> <th colspan="2">20mph</th> <th colspan="2">25mph</th> </tr> <tr> <td></td> <td>M16A4</td> <td>M4</td> <td>M16A4</td> <td>M4</td> <td>M16A4</td> <td>M4</td> <td>M16A4</td> <td>M4</td> <td>M16A4</td> <td>M4</td> </tr> </thead> <tbody> <tr> <td>FULL</td> <td>2</td> <td>3</td> <td>5</td> <td>5</td> <td>7</td> <td>8</td> <td>9</td> <td>10</td> <td>11</td> <td>19</td> </tr> <tr> <td>HALF</td> <td>1</td> <td>1</td> <td>2</td> <td>2</td> <td>3</td> <td>4</td> <td>4</td> <td>5</td> <td>5</td> <td>9</td> </tr> </tbody> </table>		VALUE	5mph		10mph		15mph		20mph		25mph			M16A4	M4	M16A4	M4	M16A4	M4	M16A4	M4	M16A4	M4	FULL	2	3	5	5	7	8	9	10	11	19	HALF	1	1	2	2	3	4	4	5	5	9		
VALUE	5mph		10mph		15mph		20mph		25mph																																										
	M16A4	M4	M16A4	M4	M16A4	M4	M16A4	M4	M16A4	M4																																									
FULL	2	3	5	5	7	8	9	10	11	19																																									
HALF	1	1	2	2	3	4	4	5	5	9																																									
<b>WEATHER DATA</b>				<b>PLOT</b>										<b>AFTER FIRING</b>																																					
LIGHT <input type="checkbox"/> OVERCAST <input type="checkbox"/> PARTLY CLOUDY <input type="checkbox"/> CLEAR				PRECIP <input type="checkbox"/> DRY <input type="checkbox"/> LT RAIN <input type="checkbox"/> MIST <input type="checkbox"/> HVY RAIN												<b>SIGHT PICTURE ADJUSTMENT (WITHOUT WIND)</b>																																			
<b>DURING FIRING</b>																<b>REMARKS</b>																																			
1	2	3	4	5	6	7	8	9	10	11	12	13	14	15	16	17	18	19	20																																

**200 YARD RAPID-FIRE**

**BEFORE FIRING**

**DAY TWO**

ZERO

+ WIND =

HOLD

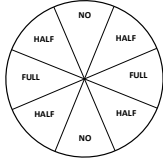

HOLDS IN INCHES

VALUE	5mph		10mph		15mph		20mph		25mph	
	M16A4	M4	M16A4	M4	M16A4	M4	M16A4	M4	M16A4	M4
FULL	2	3	5	5	7	8	9	10	11	19
HALF	1	1	2	2	3	4	4	5	5	9



**WEATHER DATA**

LIGHT

- OVERCAST
- PARTLY CLOUDY
- CLEAR
- DRY     LT RAIN
- MIST    HVY RAIN

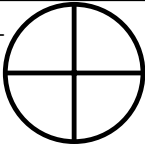

**REMARKS**

**AFTER FIRING**

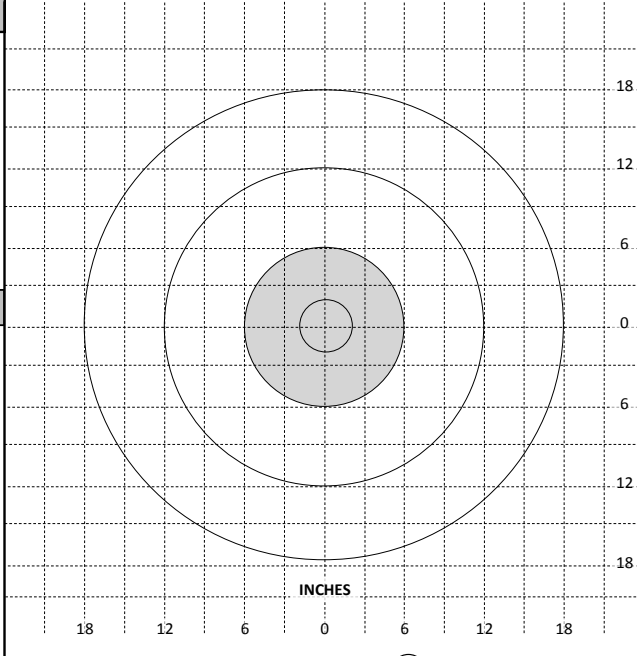

**200 YARD RAPID-FIRE**

**BEFORE FIRING**

**DAY TWO**

ZERO

+ WIND =

HOLD

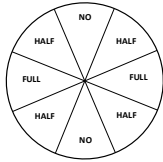

HOLDS IN INCHES

VALUE	5mph		10mph		15mph		20mph		25mph	
	M16A4	M4	M16A4	M4	M16A4	M4	M16A4	M4	M16A4	M4
FULL	2	3	5	5	7	8	9	10	11	19
HALF	1	1	2	2	3	4	4	5	5	9



**WEATHER DATA**

LIGHT

- OVERCAST
- PARTLY CLOUDY
- CLEAR
- DRY     LT RAIN
- MIST    HVY RAIN

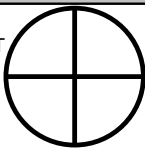





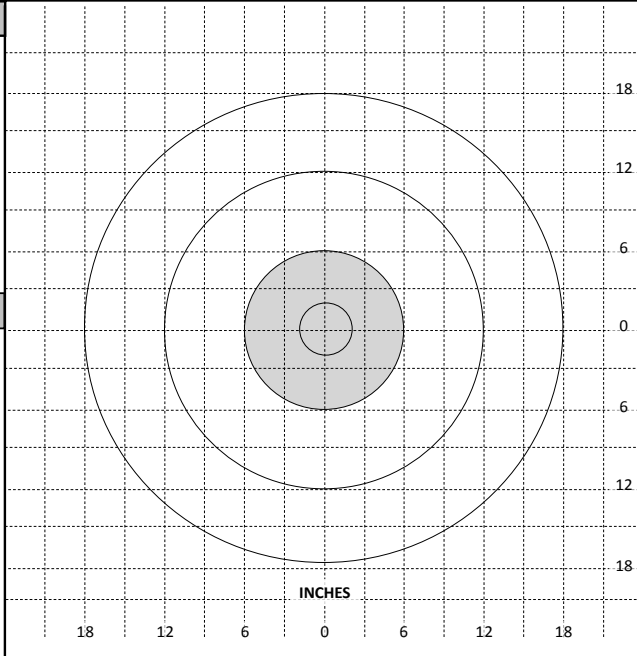

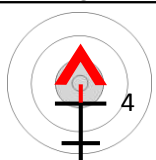
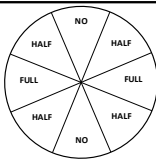

**REMARKS**

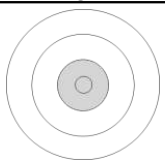
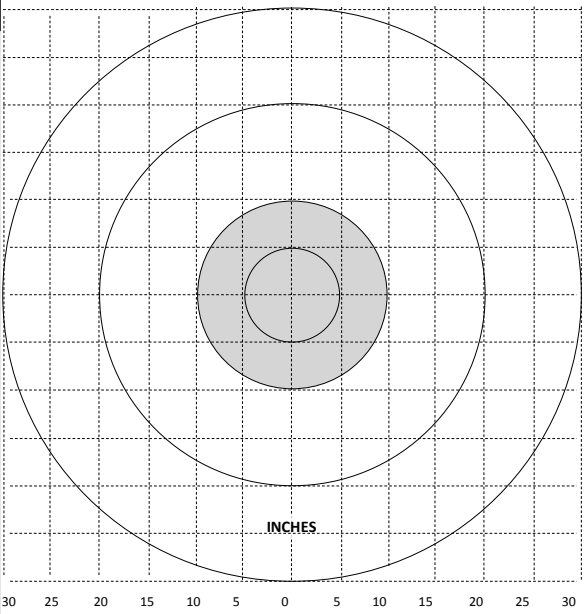

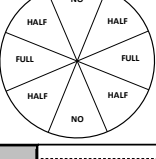

**AFTER FIRING**

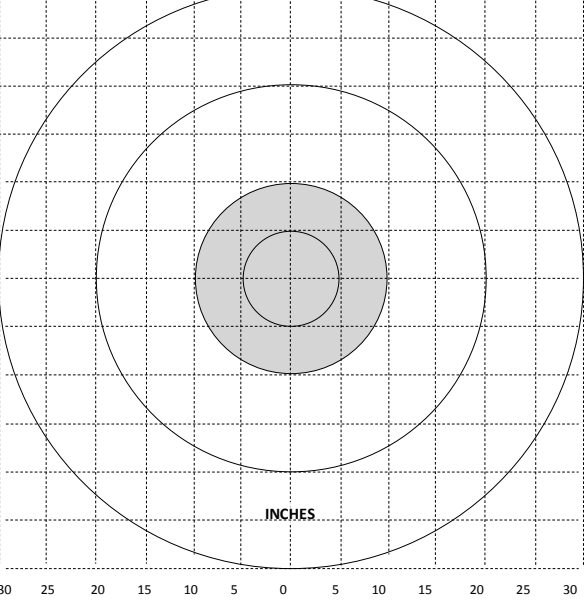



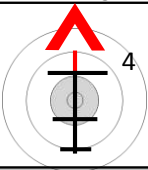
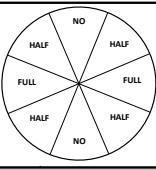

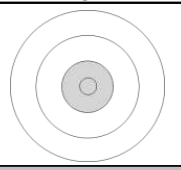
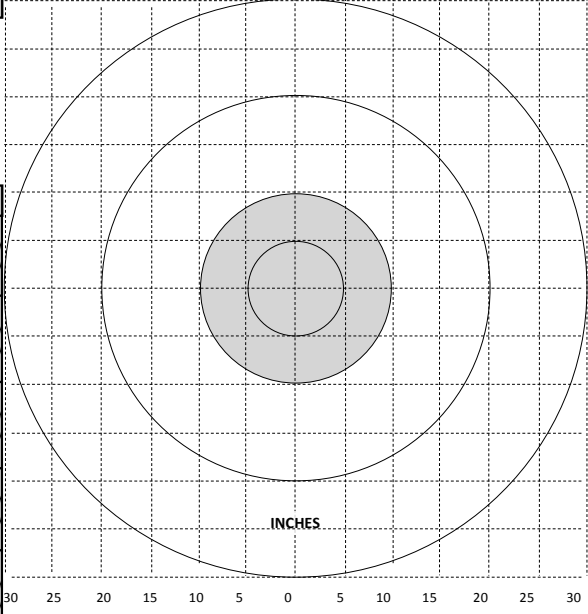

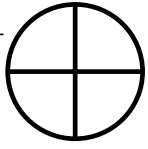
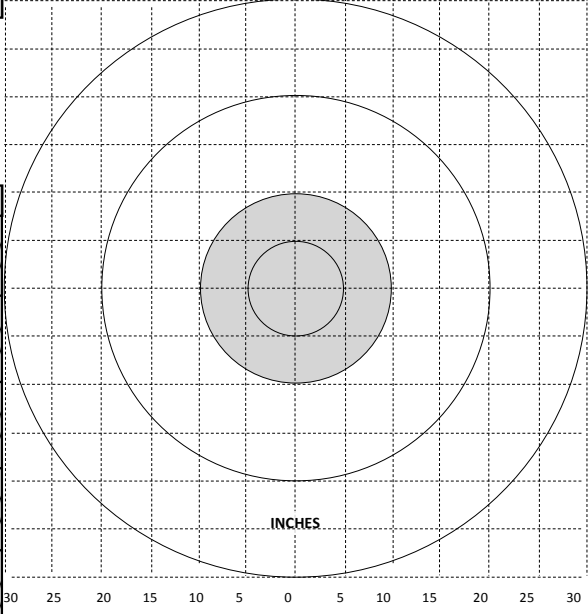

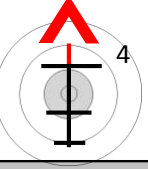
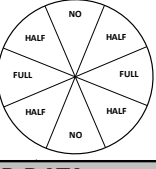

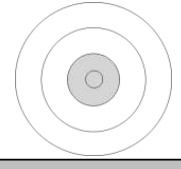
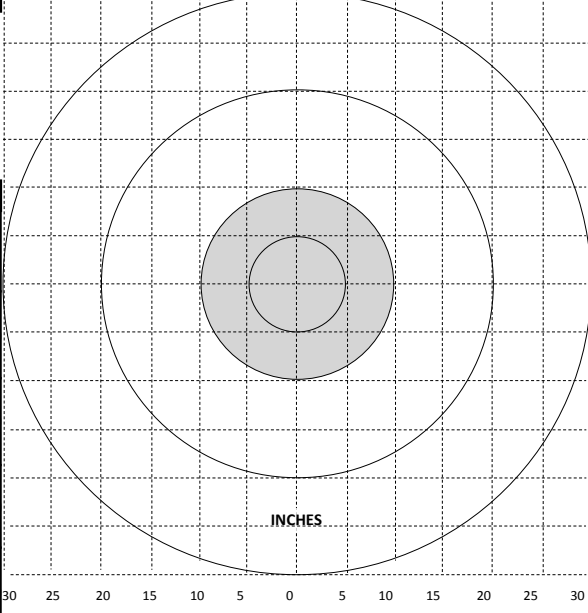

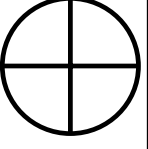
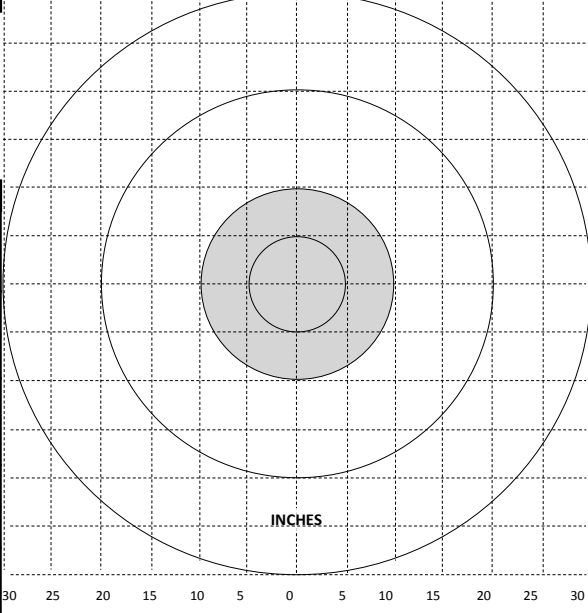
<b>300 YARD RAPID-FIRE</b>		<b>BEFORE FIRING</b>										<b>DAY TWO</b>																																					
<b>ZERO</b>		<b>+ WIND =</b>										<b>HOLD</b>																																					
				<b>HOLDS IN INCHES</b> 																																													
		<table border="1" style="font-size: small;"> <thead> <tr> <th>VALUE</th> <th colspan="2">5mph</th> <th colspan="2">10mph</th> <th colspan="2">15mph</th> <th colspan="2">20mph</th> <th colspan="2">25mph</th> </tr> <tr> <th></th> <th>M16A4</th> <th>M4</th> <th>M16A4</th> <th>M4</th> <th>M16A4</th> <th>M4</th> <th>M16A4</th> <th>M4</th> <th>M16A4</th> <th>M4</th> </tr> </thead> <tbody> <tr> <td>FULL</td> <td>5</td> <td>6</td> <td>11</td> <td>13</td> <td>16</td> <td>18</td> <td>22</td> <td>25</td> <td>27</td> <td>32</td> </tr> <tr> <td>HALF</td> <td>2</td> <td>3</td> <td>5</td> <td>6</td> <td>8</td> <td>9</td> <td>11</td> <td>12</td> <td>13</td> <td>16</td> </tr> </tbody> </table>		VALUE	5mph		10mph		15mph		20mph		25mph			M16A4	M4	M16A4	M4	M16A4	M4	M16A4	M4	M16A4	M4	FULL	5	6	11	13	16	18	22	25	27	32	HALF	2	3	5	6	8	9	11	12	13	16		
VALUE	5mph		10mph		15mph		20mph		25mph																																								
	M16A4	M4	M16A4	M4	M16A4	M4	M16A4	M4	M16A4	M4																																							
FULL	5	6	11	13	16	18	22	25	27	32																																							
HALF	2	3	5	6	8	9	11	12	13	16																																							
<b>WEATHER DATA</b>												<b>REMARKS</b>																																					
LIGHT <input type="checkbox"/> OVERCAST <input type="checkbox"/> PARTLY CLOUDY <input type="checkbox"/> CLEAR <input type="checkbox"/> DRY <input type="checkbox"/> LT RAIN <input type="checkbox"/> MIST <input type="checkbox"/> HVY RAIN												<b>AFTER FIRING</b>																																					



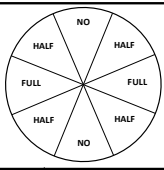

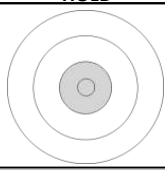
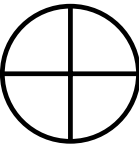
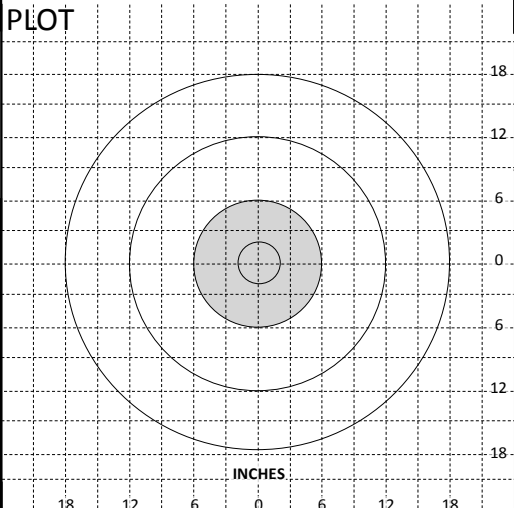
<b>300 YARD RAPID-FIRE</b>		<b>BEFORE FIRING</b>										<b>DAY TWO</b>																																					
<b>ZERO</b>		<b>+ WIND =</b>										<b>HOLD</b>																																					
				<b>HOLDS IN INCHES</b> 																																													
		<table border="1" style="font-size: small;"> <thead> <tr> <th>VALUE</th> <th colspan="2">5mph</th> <th colspan="2">10mph</th> <th colspan="2">15mph</th> <th colspan="2">20mph</th> <th colspan="2">25mph</th> </tr> <tr> <th></th> <th>M16A4</th> <th>M4</th> <th>M16A4</th> <th>M4</th> <th>M16A4</th> <th>M4</th> <th>M16A4</th> <th>M4</th> <th>M16A4</th> <th>M4</th> </tr> </thead> <tbody> <tr> <td>FULL</td> <td>5</td> <td>6</td> <td>11</td> <td>13</td> <td>16</td> <td>18</td> <td>22</td> <td>25</td> <td>27</td> <td>32</td> </tr> <tr> <td>HALF</td> <td>2</td> <td>3</td> <td>5</td> <td>6</td> <td>8</td> <td>9</td> <td>11</td> <td>12</td> <td>13</td> <td>16</td> </tr> </tbody> </table>		VALUE	5mph		10mph		15mph		20mph		25mph			M16A4	M4	M16A4	M4	M16A4	M4	M16A4	M4	M16A4	M4	FULL	5	6	11	13	16	18	22	25	27	32	HALF	2	3	5	6	8	9	11	12	13	16		
VALUE	5mph		10mph		15mph		20mph		25mph																																								
	M16A4	M4	M16A4	M4	M16A4	M4	M16A4	M4	M16A4	M4																																							
FULL	5	6	11	13	16	18	22	25	27	32																																							
HALF	2	3	5	6	8	9	11	12	13	16																																							
<b>WEATHER DATA</b>												<b>REMARKS</b>																																					
LIGHT <input type="checkbox"/> OVERCAST <input type="checkbox"/> PARTLY CLOUDY <input type="checkbox"/> CLEAR <input type="checkbox"/> DRY <input type="checkbox"/> LT RAIN <input type="checkbox"/> MIST <input type="checkbox"/> HVY RAIN												<b>AFTER FIRING</b>																																					

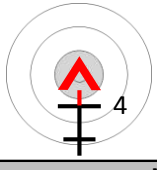
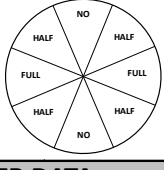

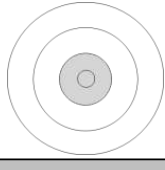
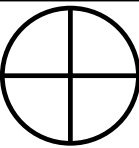
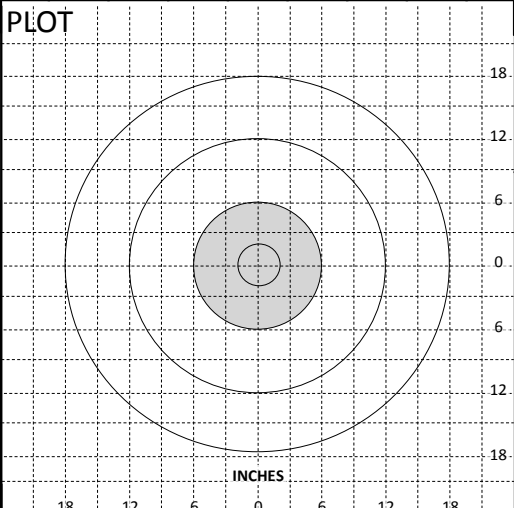

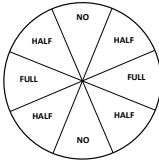
500 YARD SLOW-FIRE				BEFORE FIRING										DAY TWO																												
ZERO				+ WIND =										HOLD																												
				HOLDS IN INCHES 																																						
				<table border="1" style="font-size: small;"> <thead> <tr> <th>VALUE</th> <th>5mph M16A4</th> <th>M4</th> <th>10mph M16A4</th> <th>M4</th> <th>15mph M16A4</th> <th>M4</th> <th>20mph M16A4</th> <th>M4</th> <th>25mph M16A4</th> <th>M4</th> </tr> </thead> <tbody> <tr> <td>FULL</td> <td>17</td> <td>20</td> <td>35</td> <td>40</td> <td>52</td> <td>60</td> <td>69</td> <td>81</td> <td>87</td> <td>101</td> </tr> <tr> <td>HALF</td> <td>8</td> <td>10</td> <td>17</td> <td>20</td> <td>26</td> <td>30</td> <td>34</td> <td>40</td> <td>43</td> <td>50</td> </tr> </tbody> </table>		VALUE	5mph M16A4	M4	10mph M16A4	M4	15mph M16A4	M4	20mph M16A4	M4	25mph M16A4	M4	FULL	17	20	35	40	52	60	69	81	87	101	HALF	8	10	17	20	26	30	34	40	43	50				
VALUE	5mph M16A4	M4	10mph M16A4	M4	15mph M16A4	M4	20mph M16A4	M4	25mph M16A4	M4																																
FULL	17	20	35	40	52	60	69	81	87	101																																
HALF	8	10	17	20	26	30	34	40	43	50																																
WEATHER DATA																																										
LIGHT <input type="checkbox"/> OVERCAST <input type="checkbox"/> PARTLY CLOUDY <input type="checkbox"/> CLEAR														PRECIP <input type="checkbox"/> DRY <input type="checkbox"/> LT RAIN <input type="checkbox"/> MIST <input type="checkbox"/> HVY RAIN		AFTER FIRING																										
DURING FIRING														REMARKS																												
1	2	3	4											REMARKS																												
5	6	7	8											REMARKS																												
9	10	11	12											REMARKS																												
13	14	15	16											REMARKS																												
17	18	19	20											REMARKS																												

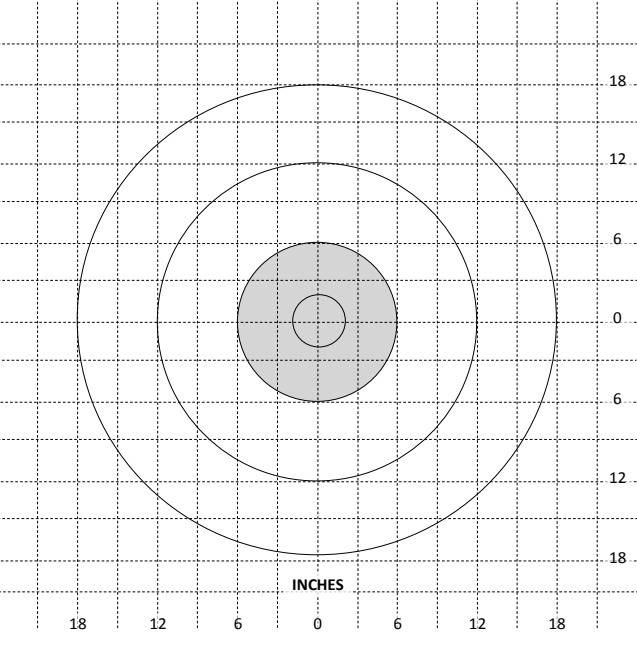
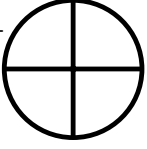
500 YARD SLOW-FIRE				BEFORE FIRING										DAY TWO																												
ZERO				+ WIND =										HOLD																												
				HOLDS IN INCHES 																																						
				<table border="1" style="font-size: small;"> <thead> <tr> <th>VALUE</th> <th>5mph M16A4</th> <th>M4</th> <th>10mph M16A4</th> <th>M4</th> <th>15mph M16A4</th> <th>M4</th> <th>20mph M16A4</th> <th>M4</th> <th>25mph M16A4</th> <th>M4</th> </tr> </thead> <tbody> <tr> <td>FULL</td> <td>17</td> <td>20</td> <td>35</td> <td>40</td> <td>52</td> <td>60</td> <td>69</td> <td>81</td> <td>87</td> <td>101</td> </tr> <tr> <td>HALF</td> <td>8</td> <td>10</td> <td>17</td> <td>20</td> <td>26</td> <td>30</td> <td>34</td> <td>40</td> <td>43</td> <td>50</td> </tr> </tbody> </table>		VALUE	5mph M16A4	M4	10mph M16A4	M4	15mph M16A4	M4	20mph M16A4	M4	25mph M16A4	M4	FULL	17	20	35	40	52	60	69	81	87	101	HALF	8	10	17	20	26	30	34	40	43	50				
VALUE	5mph M16A4	M4	10mph M16A4	M4	15mph M16A4	M4	20mph M16A4	M4	25mph M16A4	M4																																
FULL	17	20	35	40	52	60	69	81	87	101																																
HALF	8	10	17	20	26	30	34	40	43	50																																
WEATHER DATA																																										
LIGHT <input type="checkbox"/> OVERCAST <input type="checkbox"/> PARTLY CLOUDY <input type="checkbox"/> CLEAR														PRECIP <input type="checkbox"/> DRY <input type="checkbox"/> LT RAIN <input type="checkbox"/> MIST <input type="checkbox"/> HVY RAIN		AFTER FIRING																										
DURING FIRING														REMARKS																												
1	2	3	4											REMARKS																												
5	6	7	8											REMARKS																												
9	10	11	12											REMARKS																												
13	14	15	16											REMARKS																												
17	18	19	20											REMARKS																												

200 YARD SLOW-FIRE				BEFORE FIRING										DAY THREE																																							
ZERO						HOLDS IN INCHES $+ \text{ WIND} =$ 										HOLD 																																					
				<table border="1" style="font-size: small;"> <thead> <tr> <th>VALUE</th> <th colspan="2">5mph</th> <th colspan="2">10mph</th> <th colspan="2">15mph</th> <th colspan="2">20mph</th> <th colspan="2">25mph</th> </tr> <tr> <td>FULL</td> <td>M16A4</td> <td>M4</td> <td>M16A4</td> <td>M4</td> <td>M16A4</td> <td>M4</td> <td>M16A4</td> <td>M4</td> <td>M16A4</td> <td>M4</td> </tr> </thead> <tbody> <tr> <td>FULL</td> <td>2</td> <td>3</td> <td>5</td> <td>5</td> <td>7</td> <td>8</td> <td>9</td> <td>10</td> <td>11</td> <td>19</td> </tr> <tr> <td>HALF</td> <td>1</td> <td>1</td> <td>2</td> <td>2</td> <td>3</td> <td>4</td> <td>4</td> <td>5</td> <td>5</td> <td>9</td> </tr> </tbody> </table>		VALUE	5mph		10mph		15mph		20mph		25mph		FULL	M16A4	M4	M16A4	M4	M16A4	M4	M16A4	M4	M16A4	M4	FULL	2	3	5	5	7	8	9	10	11	19	HALF	1	1	2	2	3	4	4	5	5	9				
VALUE	5mph		10mph		15mph		20mph		25mph																																												
FULL	M16A4	M4	M16A4	M4	M16A4	M4	M16A4	M4	M16A4	M4																																											
FULL	2	3	5	5	7	8	9	10	11	19																																											
HALF	1	1	2	2	3	4	4	5	5	9																																											
WEATHER DATA				PLOT										AFTER FIRING																																							
LIGHT <input type="checkbox"/> OVERCAST <input type="checkbox"/> PARTLY CLOUDY <input type="checkbox"/> CLEAR				PRECIP <input type="checkbox"/> DRY <input type="checkbox"/> LT RAIN <input type="checkbox"/> MIST <input type="checkbox"/> HVY RAIN												SIGHT PICTURE ADJUSTMENT (WITHOUT WIND)																																					
DURING FIRING																REMARKS																																					
1	2	3	4	5	6	7	8	9	10	11	12	13	14	15	16	17	18	19	20																																		

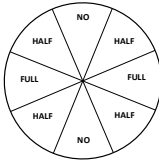
200 YARD SLOW-FIRE				BEFORE FIRING										DAY THREE																																							
ZERO						HOLDS IN INCHES $+ \text{ WIND} =$ 										HOLD 																																					
				<table border="1" style="font-size: small;"> <thead> <tr> <th>VALUE</th> <th colspan="2">5mph</th> <th colspan="2">10mph</th> <th colspan="2">15mph</th> <th colspan="2">20mph</th> <th colspan="2">25mph</th> </tr> <tr> <td>FULL</td> <td>M16A4</td> <td>M4</td> <td>M16A4</td> <td>M4</td> <td>M16A4</td> <td>M4</td> <td>M16A4</td> <td>M4</td> <td>M16A4</td> <td>M4</td> </tr> </thead> <tbody> <tr> <td>FULL</td> <td>2</td> <td>3</td> <td>5</td> <td>5</td> <td>7</td> <td>8</td> <td>9</td> <td>10</td> <td>11</td> <td>19</td> </tr> <tr> <td>HALF</td> <td>1</td> <td>1</td> <td>2</td> <td>2</td> <td>3</td> <td>4</td> <td>4</td> <td>5</td> <td>5</td> <td>9</td> </tr> </tbody> </table>		VALUE	5mph		10mph		15mph		20mph		25mph		FULL	M16A4	M4	M16A4	M4	M16A4	M4	M16A4	M4	M16A4	M4	FULL	2	3	5	5	7	8	9	10	11	19	HALF	1	1	2	2	3	4	4	5	5	9				
VALUE	5mph		10mph		15mph		20mph		25mph																																												
FULL	M16A4	M4	M16A4	M4	M16A4	M4	M16A4	M4	M16A4	M4																																											
FULL	2	3	5	5	7	8	9	10	11	19																																											
HALF	1	1	2	2	3	4	4	5	5	9																																											
WEATHER DATA				PLOT										AFTER FIRING																																							
LIGHT <input type="checkbox"/> OVERCAST <input type="checkbox"/> PARTLY CLOUDY <input type="checkbox"/> CLEAR				PRECIP <input type="checkbox"/> DRY <input type="checkbox"/> LT RAIN <input type="checkbox"/> MIST <input type="checkbox"/> HVY RAIN												SIGHT PICTURE ADJUSTMENT (WITHOUT WIND)																																					
DURING FIRING																REMARKS																																					
1	2	3	4	5	6	7	8	9	10	11	12	13	14	15	16	17	18	19	20																																		

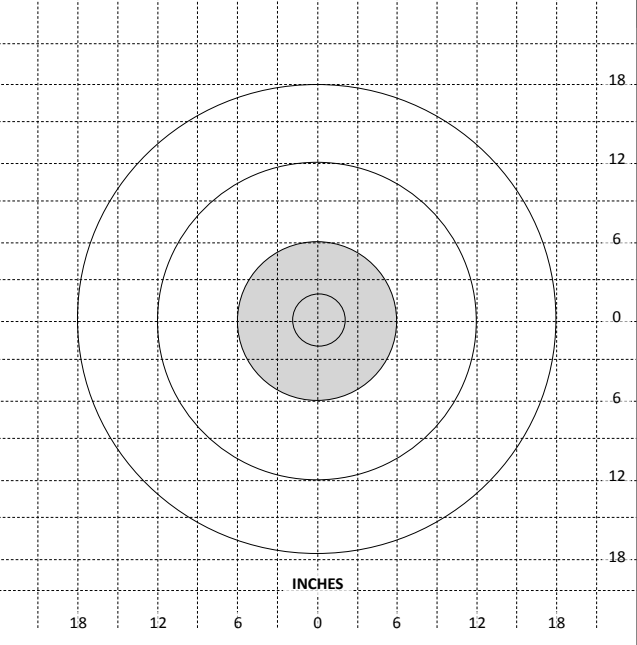
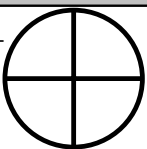
200 YARD RAPID-FIRE		BEFORE FIRING										DAY THREE																																													
ZERO		+ WIND =										HOLD																																													
		HOLDS IN INCHES 																																																							
		<table border="1" style="font-size: small;"> <thead> <tr> <th>VALUE</th> <th colspan="2">5mph</th> <th colspan="2">10mph</th> <th colspan="2">15mph</th> <th colspan="2">20mph</th> <th colspan="2">25mph</th> </tr> <tr> <td></td> <th>M16A4</th> <th>M4</th> <th>M16A4</th> <th>M4</th> <th>M16A4</th> <th>M4</th> <th>M16A4</th> <th>M4</th> <th>M16A4</th> <th>M4</th> </tr> </thead> <tbody> <tr> <td>FULL</td> <td>2</td> <td>3</td> <td>5</td> <td>5</td> <td>7</td> <td>8</td> <td>9</td> <td>10</td> <td>11</td> <td>19</td> </tr> <tr> <td>HALF</td> <td>1</td> <td>1</td> <td>2</td> <td>2</td> <td>3</td> <td>4</td> <td>4</td> <td>5</td> <td>5</td> <td>9</td> </tr> </tbody> </table>		VALUE	5mph		10mph		15mph		20mph		25mph			M16A4	M4	M16A4	M4	M16A4	M4	M16A4	M4	M16A4	M4	FULL	2	3	5	5	7	8	9	10	11	19	HALF	1	1	2	2	3	4	4	5	5	9										
VALUE	5mph		10mph		15mph		20mph		25mph																																																
	M16A4	M4	M16A4	M4	M16A4	M4	M16A4	M4	M16A4	M4																																															
FULL	2	3	5	5	7	8	9	10	11	19																																															
HALF	1	1	2	2	3	4	4	5	5	9																																															
<b>WEATHER DATA</b>												<b>REMARKS</b>																																													
LIGHT <input type="checkbox"/> OVERCAST  <input type="checkbox"/> PARTLY CLOUDY <input type="checkbox"/> CLEAR <input type="checkbox"/> DRY <input type="checkbox"/> LT RAIN <input type="checkbox"/> MIST <input type="checkbox"/> HVY RAIN												<b>AFTER FIRING</b>																																													
																																																									

200 YARD RAPID-FIRE		BEFORE FIRING										DAY THREE																																													
ZERO		+ WIND =										HOLD																																													
		HOLDS IN INCHES 																																																							
		<table border="1" style="font-size: small;"> <thead> <tr> <th>VALUE</th> <th colspan="2">5mph</th> <th colspan="2">10mph</th> <th colspan="2">15mph</th> <th colspan="2">20mph</th> <th colspan="2">25mph</th> </tr> <tr> <td></td> <th>M16A4</th> <th>M4</th> <th>M16A4</th> <th>M4</th> <th>M16A4</th> <th>M4</th> <th>M16A4</th> <th>M4</th> <th>M16A4</th> <th>M4</th> </tr> </thead> <tbody> <tr> <td>FULL</td> <td>2</td> <td>3</td> <td>5</td> <td>5</td> <td>7</td> <td>8</td> <td>9</td> <td>10</td> <td>11</td> <td>19</td> </tr> <tr> <td>HALF</td> <td>1</td> <td>1</td> <td>2</td> <td>2</td> <td>3</td> <td>4</td> <td>4</td> <td>5</td> <td>5</td> <td>9</td> </tr> </tbody> </table>		VALUE	5mph		10mph		15mph		20mph		25mph			M16A4	M4	M16A4	M4	M16A4	M4	M16A4	M4	M16A4	M4	FULL	2	3	5	5	7	8	9	10	11	19	HALF	1	1	2	2	3	4	4	5	5	9										
VALUE	5mph		10mph		15mph		20mph		25mph																																																
	M16A4	M4	M16A4	M4	M16A4	M4	M16A4	M4	M16A4	M4																																															
FULL	2	3	5	5	7	8	9	10	11	19																																															
HALF	1	1	2	2	3	4	4	5	5	9																																															
<b>WEATHER DATA</b>												<b>REMARKS</b>																																													
LIGHT <input type="checkbox"/> OVERCAST  <input type="checkbox"/> PARTLY CLOUDY <input type="checkbox"/> CLEAR <input type="checkbox"/> DRY <input type="checkbox"/> LT RAIN <input type="checkbox"/> MIST <input type="checkbox"/> HVY RAIN												<b>AFTER FIRING</b>																																													
																																																									

**ZERO** **+ WIND =** **HOLD**

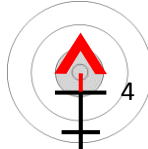
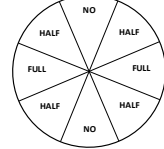
HOLDS IN INCHES

VALUE	5mph		10mph		15mph		20mph		25mph	
	M16A4	M4	M16A4	M4	M16A4	M4	M16A4	M4	M16A4	M4
FULL	5	6	11	13	16	18	22	25	27	32
HALF	2	3	5	6	8	9	11	12	13	16



**WEATHER DATA**

LIGHT

OVERCAST

PARTLY CLOUDY

CLEAR

DRY  LT RAIN

MIST  HVY RAIN

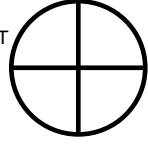
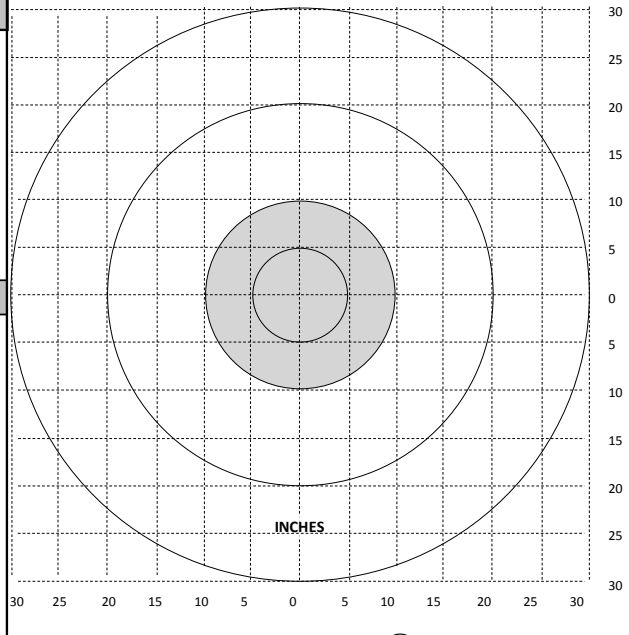
**REMARKS**

**ZERO** **+ WIND =** **HOLD**

HOLDS IN INCHES

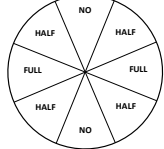
VALUE	5mph		10mph		15mph		20mph		25mph	
	M16A4	M4	M16A4	M4	M16A4	M4	M16A4	M4	M16A4	M4
FULL	5	6	11	13	16	18	22	25	27	32
HALF	2	3	5	6	8	9	11	12	13	16



**WEATHER DATA**

LIGHT

OVERCAST

PARTLY CLOUDY



CLEAR

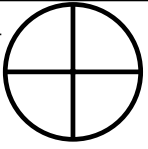
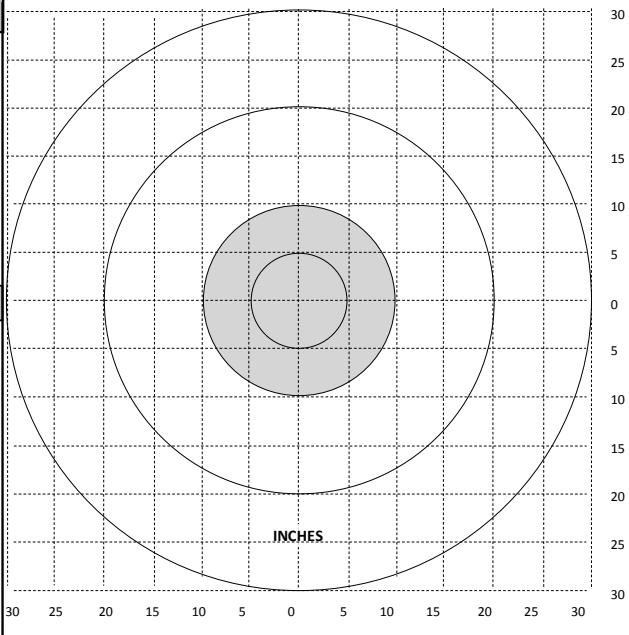

DRY  LT RAIN



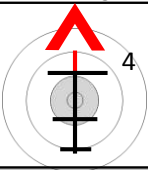
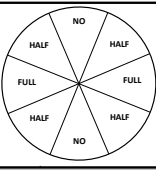

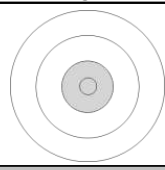
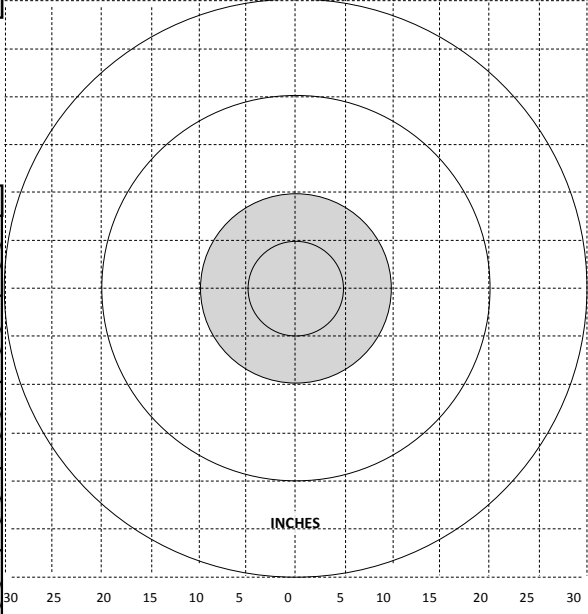
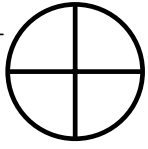
MIST  HVY RAIN

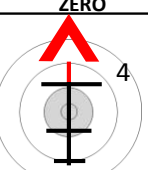
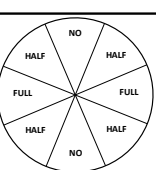

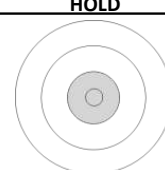
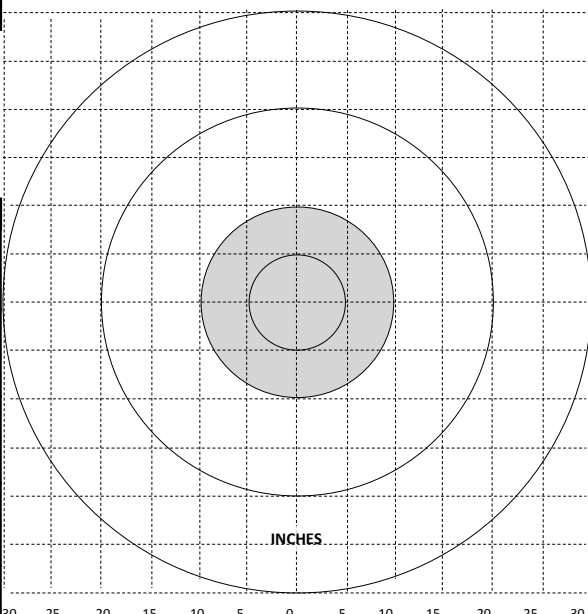
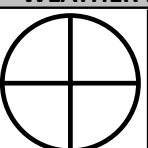

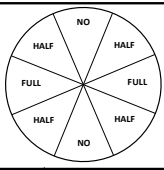

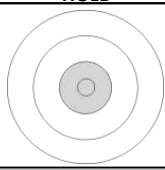
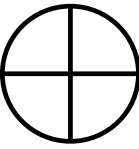
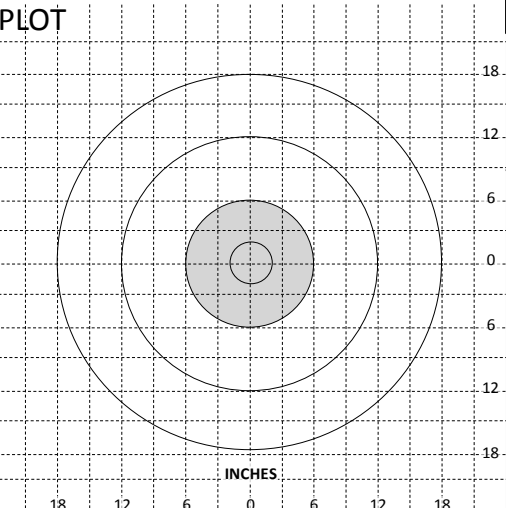
**REMARKS**

500 YARD SLOW-FIRE				BEFORE FIRING										DAY THREE																																													
ZERO				+ WIND =										HOLD																																													
				HOLDS IN INCHES 																																																							
				<table border="1" style="width:100%; border-collapse: collapse; text-align: center;"> <thead> <tr> <th>VALUE</th> <th colspan="2">5mph</th> <th colspan="2">10mph</th> <th colspan="2">15mph</th> <th colspan="2">20mph</th> <th colspan="2">25mph</th> </tr> <tr> <th></th> <th>M16A4</th> <th>M4</th> <th>M16A4</th> <th>M4</th> <th>M16A4</th> <th>M4</th> <th>M16A4</th> <th>M4</th> <th>M16A4</th> <th>M4</th> </tr> </thead> <tbody> <tr> <td>FULL</td> <td>17</td> <td>20</td> <td>35</td> <td>40</td> <td>52</td> <td>60</td> <td>69</td> <td>81</td> <td>87</td> <td>101</td> </tr> <tr> <td>HALF</td> <td>8</td> <td>10</td> <td>17</td> <td>20</td> <td>26</td> <td>30</td> <td>34</td> <td>40</td> <td>43</td> <td>50</td> </tr> </tbody> </table>										VALUE	5mph		10mph		15mph		20mph		25mph			M16A4	M4	M16A4	M4	M16A4	M4	M16A4	M4	M16A4	M4	FULL	17	20	35	40	52	60	69	81	87	101	HALF	8	10	17	20	26	30	34	40	43	50		
VALUE	5mph		10mph		15mph		20mph		25mph																																																		
	M16A4	M4	M16A4	M4	M16A4	M4	M16A4	M4	M16A4	M4																																																	
FULL	17	20	35	40	52	60	69	81	87	101																																																	
HALF	8	10	17	20	26	30	34	40	43	50																																																	
<b>WEATHER DATA</b>														<b>AFTER FIRING</b>																																													
LIGHT <input type="checkbox"/> OVERCAST <input type="checkbox"/> PARTLY CLOUDY <input type="checkbox"/> CLEAR														PRECIP <input type="checkbox"/> DRY <input type="checkbox"/> LT RAIN <input type="checkbox"/> MIST <input type="checkbox"/> HVY RAIN		<b>REMARKS</b>																																											
<b>DURING FIRING</b>																																																											
1		2		3		4		5		6		7		8		9		10		11		12		13		14		15		16		17		18		19		20																					

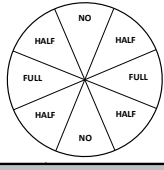
500 YARD SLOW-FIRE				BEFORE FIRING										DAY THREE																																													
ZERO				+ WIND =										HOLD																																													
				HOLDS IN INCHES 																																																							
				<table border="1" style="width:100%; border-collapse: collapse; text-align: center;"> <thead> <tr> <th>VALUE</th> <th colspan="2">5mph</th> <th colspan="2">10mph</th> <th colspan="2">15mph</th> <th colspan="2">20mph</th> <th colspan="2">25mph</th> </tr> <tr> <th></th> <th>M16A4</th> <th>M4</th> <th>M16A4</th> <th>M4</th> <th>M16A4</th> <th>M4</th> <th>M16A4</th> <th>M4</th> <th>M16A4</th> <th>M4</th> </tr> </thead> <tbody> <tr> <td>FULL</td> <td>17</td> <td>20</td> <td>35</td> <td>40</td> <td>52</td> <td>60</td> <td>69</td> <td>81</td> <td>87</td> <td>101</td> </tr> <tr> <td>HALF</td> <td>8</td> <td>10</td> <td>17</td> <td>20</td> <td>26</td> <td>30</td> <td>34</td> <td>40</td> <td>43</td> <td>50</td> </tr> </tbody> </table>										VALUE	5mph		10mph		15mph		20mph		25mph			M16A4	M4	M16A4	M4	M16A4	M4	M16A4	M4	M16A4	M4	FULL	17	20	35	40	52	60	69	81	87	101	HALF	8	10	17	20	26	30	34	40	43	50		
VALUE	5mph		10mph		15mph		20mph		25mph																																																		
	M16A4	M4	M16A4	M4	M16A4	M4	M16A4	M4	M16A4	M4																																																	
FULL	17	20	35	40	52	60	69	81	87	101																																																	
HALF	8	10	17	20	26	30	34	40	43	50																																																	
<b>WEATHER DATA</b>														<b>AFTER FIRING</b>																																													
LIGHT <input type="checkbox"/> OVERCAST <input type="checkbox"/> PARTLY CLOUDY <input type="checkbox"/> CLEAR														PRECIP <input type="checkbox"/> DRY <input type="checkbox"/> LT RAIN <input type="checkbox"/> MIST <input type="checkbox"/> HVY RAIN		<b>REMARKS</b>																																											
<b>DURING FIRING</b>																																																											
1		2		3		4		5		6		7		8		9		10		11		12		13		14		15		16		17		18		19		20																					

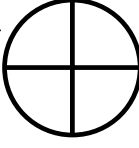
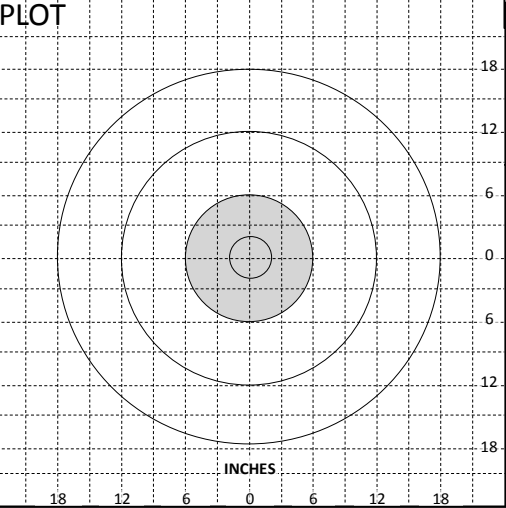
200 YARD SLOW-FIRE				BEFORE FIRING										DAY FOUR																																					
ZERO				+ WIND =										HOLD																																					
				HOLDS IN INCHES 																																															
				<table border="1" style="font-size: small;"> <thead> <tr> <th>VALUE</th> <th colspan="2">5mph</th> <th colspan="2">10mph</th> <th colspan="2">15mph</th> <th colspan="2">20mph</th> <th colspan="2">25mph</th> </tr> <tr> <td></td> <td>M16A4</td> <td>M4</td> <td>M16A4</td> <td>M4</td> <td>M16A4</td> <td>M4</td> <td>M16A4</td> <td>M4</td> <td>M16A4</td> <td>M4</td> </tr> </thead> <tbody> <tr> <td>FULL</td> <td>2</td> <td>3</td> <td>5</td> <td>5</td> <td>7</td> <td>8</td> <td>9</td> <td>10</td> <td>11</td> <td>19</td> </tr> <tr> <td>HALF</td> <td>1</td> <td>1</td> <td>2</td> <td>2</td> <td>3</td> <td>4</td> <td>4</td> <td>5</td> <td>5</td> <td>9</td> </tr> </tbody> </table>		VALUE	5mph		10mph		15mph		20mph		25mph			M16A4	M4	M16A4	M4	M16A4	M4	M16A4	M4	M16A4	M4	FULL	2	3	5	5	7	8	9	10	11	19	HALF	1	1	2	2	3	4	4	5	5	9		
VALUE	5mph		10mph		15mph		20mph		25mph																																										
	M16A4	M4	M16A4	M4	M16A4	M4	M16A4	M4	M16A4	M4																																									
FULL	2	3	5	5	7	8	9	10	11	19																																									
HALF	1	1	2	2	3	4	4	5	5	9																																									
<b>WEATHER DATA</b>				<b>PLOT</b>										<b>AFTER FIRING</b>																																					
LIGHT <input type="checkbox"/> OVERCAST <input type="checkbox"/> PARTLY CLOUDY <input type="checkbox"/> CLEAR				PRECIP <input type="checkbox"/> DRY <input type="checkbox"/> LT RAIN <input type="checkbox"/> MIST <input type="checkbox"/> HVY RAIN												<b>SIGHT PICTURE ADJUSTMENT (WITHOUT WIND)</b>																																			
<b>DURING FIRING</b>				<b>REMARKS</b>																																															
1	2	3	4																																																
5	6	7	8																																																
9	10	11	12																																																
13	14	15	16																																																
17	18	19	20																																																

200 YARD SLOW-FIRE				BEFORE FIRING										DAY FOUR																																					
ZERO				+ WIND =										HOLD																																					
				HOLDS IN INCHES 																																															
				<table border="1" style="font-size: small;"> <thead> <tr> <th>VALUE</th> <th colspan="2">5mph</th> <th colspan="2">10mph</th> <th colspan="2">15mph</th> <th colspan="2">20mph</th> <th colspan="2">25mph</th> </tr> <tr> <td></td> <td>M16A4</td> <td>M4</td> <td>M16A4</td> <td>M4</td> <td>M16A4</td> <td>M4</td> <td>M16A4</td> <td>M4</td> <td>M16A4</td> <td>M4</td> </tr> </thead> <tbody> <tr> <td>FULL</td> <td>2</td> <td>3</td> <td>5</td> <td>5</td> <td>7</td> <td>8</td> <td>9</td> <td>10</td> <td>11</td> <td>19</td> </tr> <tr> <td>HALF</td> <td>1</td> <td>1</td> <td>2</td> <td>2</td> <td>3</td> <td>4</td> <td>4</td> <td>5</td> <td>5</td> <td>9</td> </tr> </tbody> </table>		VALUE	5mph		10mph		15mph		20mph		25mph			M16A4	M4	M16A4	M4	M16A4	M4	M16A4	M4	M16A4	M4	FULL	2	3	5	5	7	8	9	10	11	19	HALF	1	1	2	2	3	4	4	5	5	9		
VALUE	5mph		10mph		15mph		20mph		25mph																																										
	M16A4	M4	M16A4	M4	M16A4	M4	M16A4	M4	M16A4	M4																																									
FULL	2	3	5	5	7	8	9	10	11	19																																									
HALF	1	1	2	2	3	4	4	5	5	9																																									
<b>WEATHER DATA</b>				<b>PLOT</b>										<b>AFTER FIRING</b>																																					
LIGHT <input type="checkbox"/> OVERCAST <input type="checkbox"/> PARTLY CLOUDY <input type="checkbox"/> CLEAR				PRECIP <input type="checkbox"/> DRY <input type="checkbox"/> LT RAIN <input type="checkbox"/> MIST <input type="checkbox"/> HVY RAIN												<b>SIGHT PICTURE ADJUSTMENT (WITHOUT WIND)</b>																																			
<b>DURING FIRING</b>				<b>REMARKS</b>																																															
1	2	3	4																																																
5	6	7	8																																																
9	10	11	12																																																
13	14	15	16																																																
17	18	19	20																																																

200 YARD RAPID-FIRE		BEFORE FIRING										DAY FOUR		
ZERO		+ WIND =										HOLD		
		HOLDS IN INCHES												
		VALUE	5mph		10mph		15mph		20mph		25mph			
			M16A4	M4	M16A4	M4	M16A4	M4	M16A4	M4	M16A4	M4		
		FULL	2	3	5	5	7	8	9	10	11	19		
		HALF	1	1	2	2	3	4	4	5	5	9		
<b>WEATHER DATA</b>												<b>REMARKS</b>		
LIGHT <input type="checkbox"/> OVERCAST <input type="checkbox"/> PARTLY CLOUDY <input type="checkbox"/> CLEAR <input type="checkbox"/> DRY <input type="checkbox"/> LT RAIN <input type="checkbox"/> MIST <input type="checkbox"/> HVY RAIN												REMARKS		
<b>AFTER FIRING</b>														

200 YARD RAPID-FIRE		BEFORE FIRING										DAY FOUR		
ZERO		+ WIND =										HOLD		
		HOLDS IN INCHES												
		VALUE	5mph		10mph		15mph		20mph		25mph			
			M16A4	M4	M16A4	M4	M16A4	M4	M16A4	M4	M16A4	M4		
		FULL	2	3	5	5	7	8	9	10	11	19		
		HALF	1	1	2	2	3	4	4	5	5	9		
<b>WEATHER DATA</b>												<b>REMARKS</b>		
LIGHT <input type="checkbox"/> OVERCAST <input type="checkbox"/> PARTLY CLOUDY <input type="checkbox"/> CLEAR <input type="checkbox"/> DRY <input type="checkbox"/> LT RAIN <input type="checkbox"/> MIST <input type="checkbox"/> HVY RAIN												REMARKS		
<b>AFTER FIRING</b>														



**300 YARD RAPID-FIRE** **BEFORE FIRING** **DAY FOUR**

**ZERO** **+ WIND =** **HOLD**

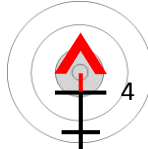
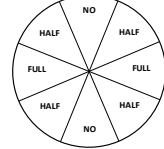
HOLDS IN INCHES

VALUE	5mph		10mph		15mph		20mph		25mph	
	M16A4	M4	M16A4	M4	M16A4	M4	M16A4	M4	M16A4	M4
FULL	5	6	11	13	16	18	22	25	27	32
HALF	2	3	5	6	8	9	11	12	13	16



**WEATHER DATA**

LIGHT

OVERCAST

PARTLY CLOUDY

CLEAR

DRY  LT RAIN

MIST  HVY RAIN

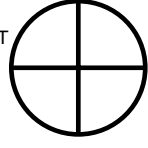
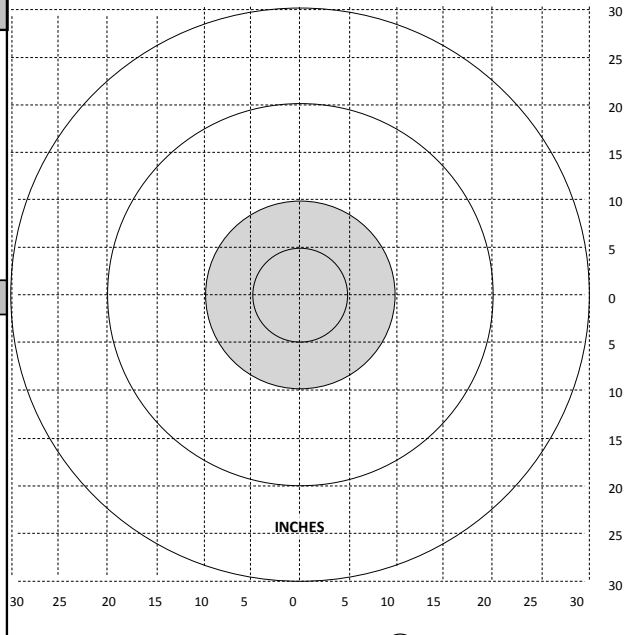
**REMARKS**

**300 YARD RAPID-FIRE** **BEFORE FIRING** **DAY FOUR**

**ZERO** **+ WIND =** **HOLD**

HOLDS IN INCHES

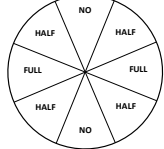
VALUE	5mph		10mph		15mph		20mph		25mph	
	M16A4	M4	M16A4	M4	M16A4	M4	M16A4	M4	M16A4	M4
FULL	5	6	11	13	16	18	22	25	27	32
HALF	2	3	5	6	8	9	11	12	13	16



**WEATHER DATA**

LIGHT

OVERCAST

PARTLY CLOUDY



CLEAR

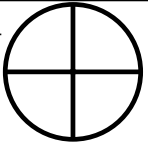
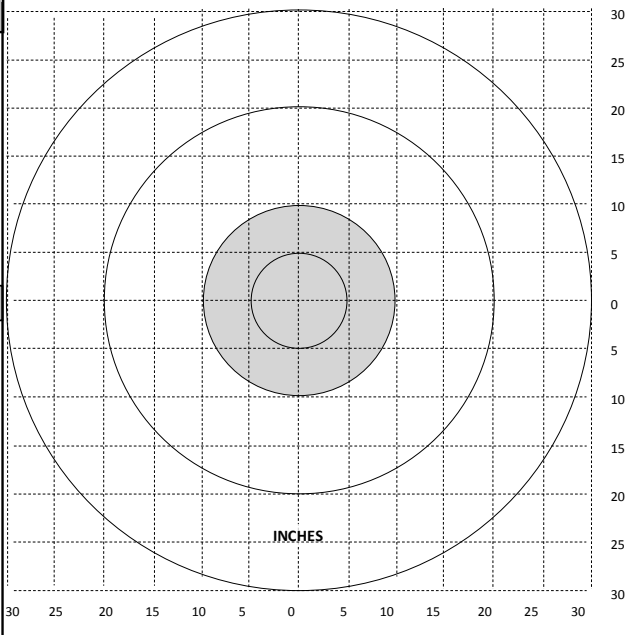

DRY  LT RAIN

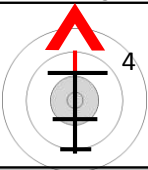
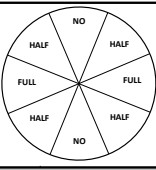

MIST  HVY RAIN

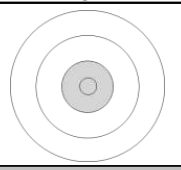
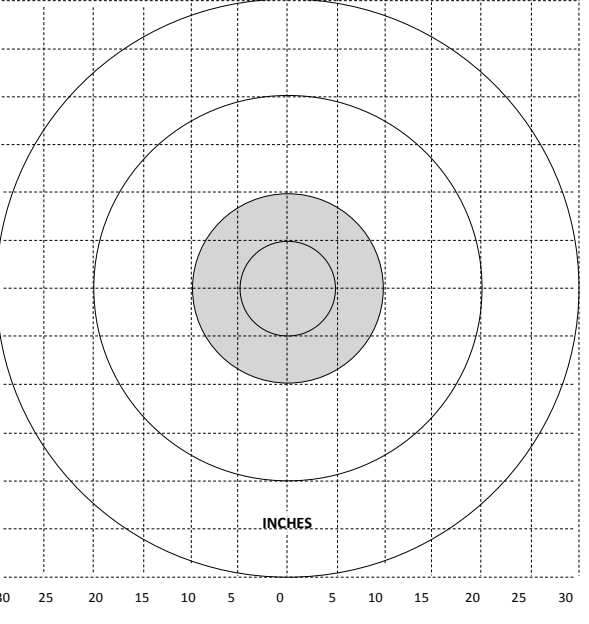
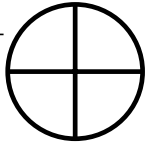

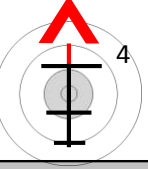
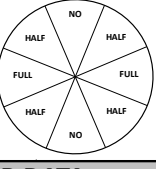

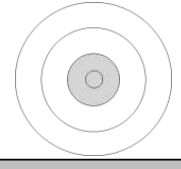
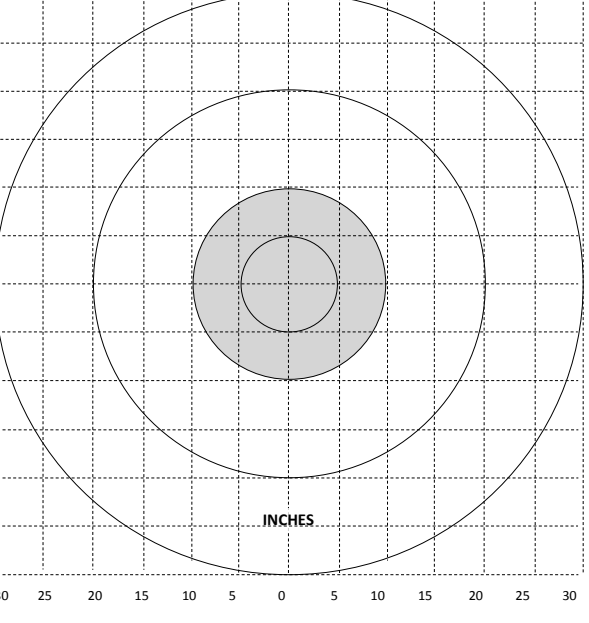
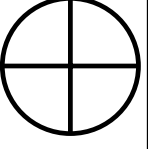

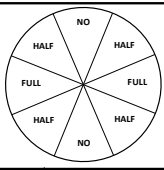
**REMARKS**

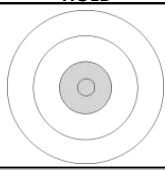
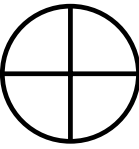
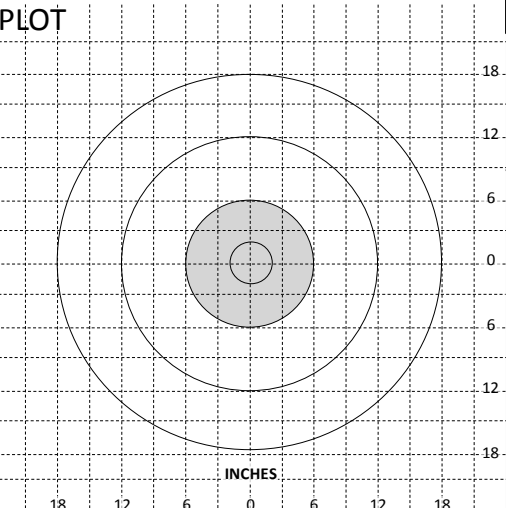
500 YARD SLOW-FIRE				BEFORE FIRING										DAY FOUR																												
ZERO				+ WIND =										HOLD																												
				HOLDS IN INCHES 																																						
				<table border="1" style="font-size: small;"> <thead> <tr> <th>VALUE</th> <th>5mph M16A4</th> <th>M4</th> <th>10mph M16A4</th> <th>M4</th> <th>15mph M16A4</th> <th>M4</th> <th>20mph M16A4</th> <th>M4</th> <th>25mph M16A4</th> <th>M4</th> </tr> </thead> <tbody> <tr> <td>FULL</td> <td>17</td> <td>20</td> <td>35</td> <td>40</td> <td>52</td> <td>60</td> <td>69</td> <td>81</td> <td>87</td> <td>101</td> </tr> <tr> <td>HALF</td> <td>8</td> <td>10</td> <td>17</td> <td>20</td> <td>26</td> <td>30</td> <td>34</td> <td>40</td> <td>43</td> <td>50</td> </tr> </tbody> </table>		VALUE	5mph M16A4	M4	10mph M16A4	M4	15mph M16A4	M4	20mph M16A4	M4	25mph M16A4	M4	FULL	17	20	35	40	52	60	69	81	87	101	HALF	8	10	17	20	26	30	34	40	43	50				
VALUE	5mph M16A4	M4	10mph M16A4	M4	15mph M16A4	M4	20mph M16A4	M4	25mph M16A4	M4																																
FULL	17	20	35	40	52	60	69	81	87	101																																
HALF	8	10	17	20	26	30	34	40	43	50																																
WEATHER DATA														AFTER FIRING																												
LIGHT <input type="checkbox"/> OVERCAST <input type="checkbox"/> PARTLY CLOUDY <input type="checkbox"/> CLEAR														PRECIP <input type="checkbox"/> DRY <input type="checkbox"/> LT RAIN <input type="checkbox"/> MIST <input type="checkbox"/> HVY RAIN		REMARKS																										
DURING FIRING																																										
1	2	3	4	5	6	7	8	9	10	11	12	13	14	15	16	17	18	19	20																							

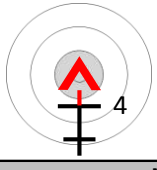
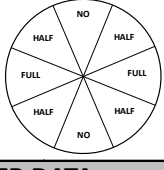
500 YARD SLOW-FIRE				BEFORE FIRING										DAY FOUR																												
ZERO				+ WIND =										HOLD																												
				HOLDS IN INCHES 																																						
				<table border="1" style="font-size: small;"> <thead> <tr> <th>VALUE</th> <th>5mph M16A4</th> <th>M4</th> <th>10mph M16A4</th> <th>M4</th> <th>15mph M16A4</th> <th>M4</th> <th>20mph M16A4</th> <th>M4</th> <th>25mph M16A4</th> <th>M4</th> </tr> </thead> <tbody> <tr> <td>FULL</td> <td>17</td> <td>20</td> <td>35</td> <td>40</td> <td>52</td> <td>60</td> <td>69</td> <td>81</td> <td>87</td> <td>101</td> </tr> <tr> <td>HALF</td> <td>8</td> <td>10</td> <td>17</td> <td>20</td> <td>26</td> <td>30</td> <td>34</td> <td>40</td> <td>43</td> <td>50</td> </tr> </tbody> </table>		VALUE	5mph M16A4	M4	10mph M16A4	M4	15mph M16A4	M4	20mph M16A4	M4	25mph M16A4	M4	FULL	17	20	35	40	52	60	69	81	87	101	HALF	8	10	17	20	26	30	34	40	43	50				
VALUE	5mph M16A4	M4	10mph M16A4	M4	15mph M16A4	M4	20mph M16A4	M4	25mph M16A4	M4																																
FULL	17	20	35	40	52	60	69	81	87	101																																
HALF	8	10	17	20	26	30	34	40	43	50																																
WEATHER DATA														AFTER FIRING																												
LIGHT <input type="checkbox"/> OVERCAST <input type="checkbox"/> PARTLY CLOUDY <input type="checkbox"/> CLEAR														PRECIP <input type="checkbox"/> DRY <input type="checkbox"/> LT RAIN <input type="checkbox"/> MIST <input type="checkbox"/> HVY RAIN		REMARKS																										
DURING FIRING																																										
1	2	3	4	5	6	7	8	9	10	11	12	13	14	15	16	17	18	19	20																							

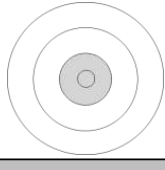
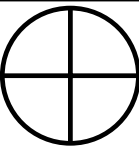
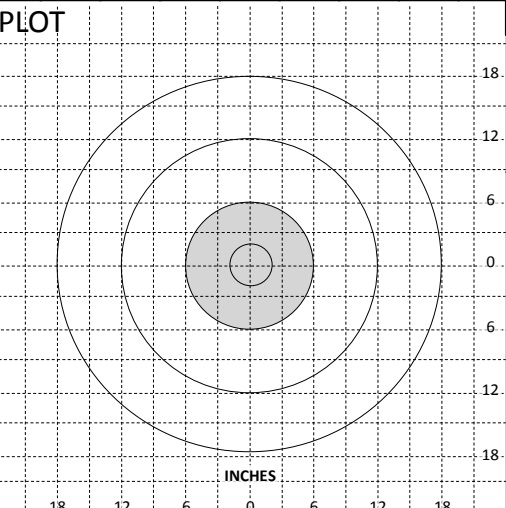
200 YARD SLOW-FIRE				BEFORE FIRING										DAY FIVE							
ZERO		+ WIND =		HOLD																	
																					
				HOLDS IN INCHES		5mph		10mph		15mph		20mph		25mph							
				M16A4		M4		M16A4		M4		M16A4		M4							
				FULL		2 3		5 5		7 8		9 10		11 19							
				HALF		1 1		2 2		3 4		4 5		5 9							
<b>WEATHER DATA</b>				<b>LOT</b>														<b>AFTER FIRING</b>			
LIGHT <input type="checkbox"/> OVERCAST <input type="checkbox"/> PARTLY CLOUDY <input type="checkbox"/> CLEAR				PRECIP <input type="checkbox"/> DRY <input type="checkbox"/> LT RAIN <input type="checkbox"/> MIST <input type="checkbox"/> HVY RAIN																<b>SIGHT PICTURE ADJUSTMENT (WITHOUT WIND)</b>	
<b>DURING FIRING</b>				<b>REMARKS</b>																	
1	2	3	4	5	6	7	8	9	10	11	12	13	14	15	16	17	18	19	20		

200 YARD SLOW-FIRE				BEFORE FIRING										DAY FIVE							
ZERO		+ WIND =		HOLD																	
																					
				HOLDS IN INCHES		5mph		10mph		15mph		20mph		25mph							
				M16A4		M4		M16A4		M4		M16A4		M4							
				FULL		2 3		5 5		7 8		9 10		11 19							
				HALF		1 1		2 2		3 4		4 5		5 9							
<b>WEATHER DATA</b>				<b>LOT</b>														<b>AFTER FIRING</b>			
LIGHT <input type="checkbox"/> OVERCAST <input type="checkbox"/> PARTLY CLOUDY <input type="checkbox"/> CLEAR				PRECIP <input type="checkbox"/> DRY <input type="checkbox"/> LT RAIN <input type="checkbox"/> MIST <input type="checkbox"/> HVY RAIN																<b>SIGHT PICTURE ADJUSTMENT (WITHOUT WIND)</b>	
<b>DURING FIRING</b>				<b>REMARKS</b>																	
1	2	3	4	5	6	7	8	9	10	11	12	13	14	15	16	17	18	19	20		

**200 YARD RAPID-FIRE** **BEFORE FIRING** **DAY FIVE**

ZERO + WIND = HOLD

HOLDS IN INCHES

VALUE	5mph		10mph		15mph		20mph		25mph	
	M16A4	M4	M16A4	M4	M16A4	M4	M16A4	M4	M16A4	M4
FULL	2	3	5	5	7	8	9	10	11	19
HALF	1	1	2	2	3	4	4	5	5	9

**WEATHER DATA**

LIGHT

OVERCAST

PARTLY CLOUDY

CLEAR

DRY  LT RAIN

MIST  HVY RAIN

**REMARKS**

**AFTER FIRING**

**200 YARD RAPID-FIRE** **BEFORE FIRING** **DAY FIVE**

ZERO + WIND = HOLD

HOLDS IN INCHES

VALUE	5mph		10mph		15mph		20mph		25mph	
	M16A4	M4	M16A4	M4	M16A4	M4	M16A4	M4	M16A4	M4
FULL	2	3	5	5	7	8	9	10	11	19
HALF	1	1	2	2	3	4	4	5	5	9

**WEATHER DATA**

LIGHT

OVERCAST

PARTLY CLOUDY

CLEAR

DRY  LT RAIN

MIST  HVY RAIN

**REMARKS**

**AFTER FIRING**

**ZERO** **+ WIND =** **HOLD**

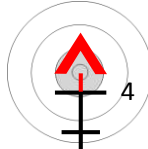
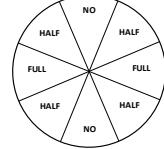
HOLDS IN INCHES

VALUE	5mph		10mph		15mph		20mph		25mph	
	M16A4	M4	M16A4	M4	M16A4	M4	M16A4	M4	M16A4	M4
FULL	5	6	11	13	16	18	22	25	27	32
HALF	2	3	5	6	8	9	11	12	13	16



**WEATHER DATA**

LIGHT

OVERCAST

PARTLY CLOUDY

CLEAR

DRY  LT RAIN

MIST  HVY RAIN

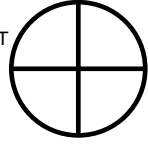
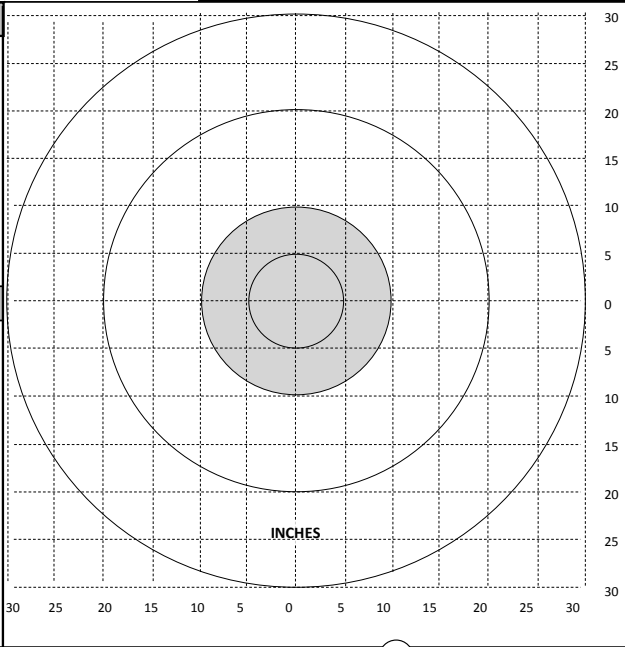
**REMARKS**

**ZERO** **+ WIND =** **HOLD**

HOLDS IN INCHES

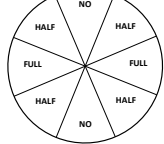
VALUE	5mph		10mph		15mph		20mph		25mph	
	M16A4	M4	M16A4	M4	M16A4	M4	M16A4	M4	M16A4	M4
FULL	5	6	11	13	16	18	22	25	27	32
HALF	2	3	5	6	8	9	11	12	13	16



**WEATHER DATA**

LIGHT

OVERCAST

PARTLY CLOUDY

CLEAR

DRY  LT RAIN

MIST  HVY RAIN

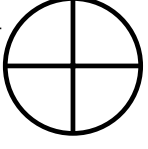
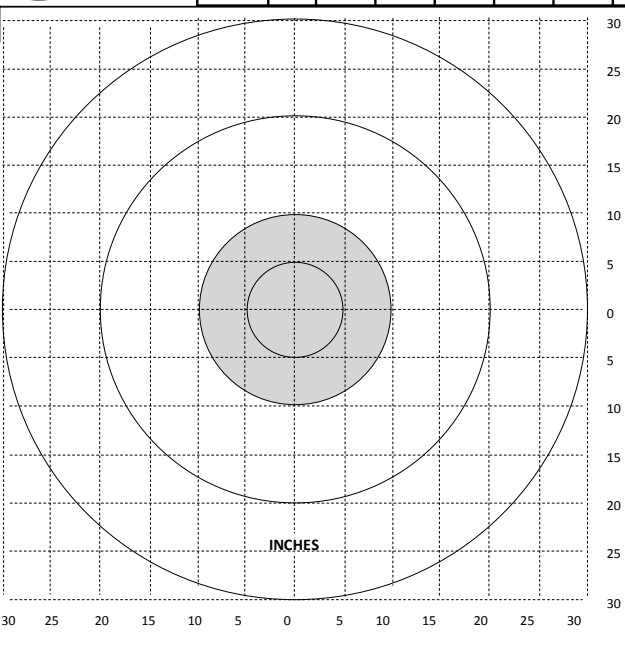
**REMARKS**

**500 YARD SLOW-FIRE**

**BEFORE FIRING**

**DAY FIVE**

**ZERO**

**HOLDS IN INCHES**

+ WIND =

**HOLD**

VALUE	5mph		10mph		15mph		20mph		25mph	
	M16A4	M4	M16A4	M4	M16A4	M4	M16A4	M4	M16A4	M4
FULL	17	20	35	40	52	60	69	81	87	101
HALF	8	10	17	20	26	30	34	40	43	50

**WEATHER DATA**

**LIGHT**

OVERCAST

PARTLY CLOUDY

CLEAR

**PRECIP**

DRY    LT RAIN

MIST    HVY RAIN

**DURING FIRING**

1	2	3	4
5	6	7	8
9	10	11	12
13	14	15	16
17	18	19	20

**AFTER FIRING**

**REMARKS**

**500 YARD SLOW-FIRE**

**BEFORE FIRING**

**DAY FIVE**

**ZERO**

**HOLDS IN INCHES**

+ WIND =

**HOLD**

VALUE	5mph		10mph		15mph		20mph		25mph	
	M16A4	M4	M16A4	M4	M16A4	M4	M16A4	M4	M16A4	M4
FULL	17	20	35	40	52	60	69	81	87	101
HALF	8	10	17	20	26	30	34	40	43	50

**WEATHER DATA**

**LIGHT**

OVERCAST

PARTLY CLOUDY

CLEAR

**PRECIP**

DRY    LT RAIN





MIST    HVY RAIN



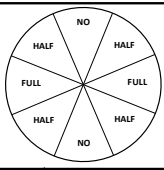

**DURING FIRING**

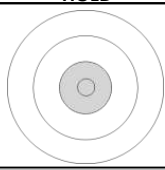
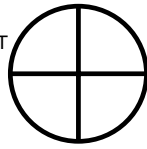
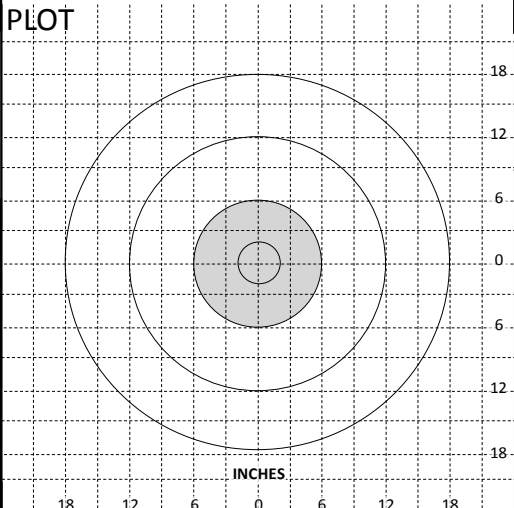
1	2	3	4
5	6	7	8
9	10	11	12
13	14	15	16
17	18	19	20

**AFTER FIRING**

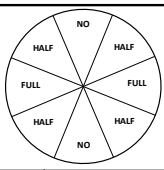
**REMARKS**

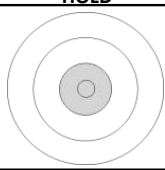
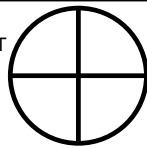
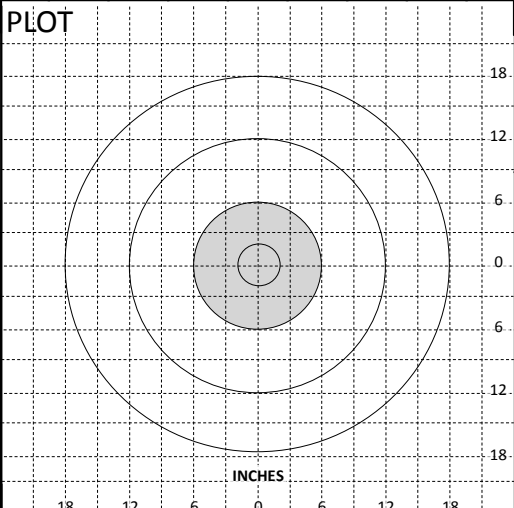
200 YARD SLOW-FIRE				BEFORE FIRING										DAY SIX																										
ZERO				+ WIND = 										HOLD																										
		HOLDS IN INCHES		<table border="1" style="font-size: 8px;"> <tr> <th>VALUE</th> <th>5mph M16A4</th> <th>M4</th> <th>10mph M16A4</th> <th>M4</th> <th>15mph M16A4</th> <th>M4</th> <th>20mph M16A4</th> <th>M4</th> <th>25mph M16A4</th> <th>M4</th> </tr> <tr> <td>FULL</td> <td>2</td> <td>3</td> <td>5</td> <td>5</td> <td>7</td> <td>8</td> <td>9</td> <td>10</td> <td>11</td> <td>19</td> </tr> <tr> <td>HALF</td> <td>1</td> <td>1</td> <td>2</td> <td>2</td> <td>3</td> <td>4</td> <td>4</td> <td>5</td> <td>5</td> <td>9</td> </tr> </table>		VALUE	5mph M16A4	M4	10mph M16A4	M4	15mph M16A4	M4	20mph M16A4	M4	25mph M16A4	M4	FULL	2	3	5	5	7	8	9	10	11	19	HALF	1	1	2	2	3	4	4	5	5	9		
VALUE	5mph M16A4	M4	10mph M16A4	M4	15mph M16A4	M4	20mph M16A4	M4	25mph M16A4	M4																														
FULL	2	3	5	5	7	8	9	10	11	19																														
HALF	1	1	2	2	3	4	4	5	5	9																														
<b>WEATHER DATA</b>				<b>PLOT</b>										<b>AFTER FIRING</b>																										
LIGHT <input type="checkbox"/> OVERCAST <input type="checkbox"/> PARTLY CLOUDY <input type="checkbox"/> CLEAR				PRECIP <input type="checkbox"/> DRY <input type="checkbox"/> LT RAIN <input type="checkbox"/> MIST <input type="checkbox"/> HVY RAIN												<b>SIGHT PICTURE ADJUSTMENT (WITHOUT WIND)</b>																								
<b>DURING FIRING</b>				<b>REMARKS</b>																																				
1	2	3	4	5	6	7	8	9	10	11	12	13	14	15	16	17	18	19	20																					

200 YARD SLOW-FIRE				BEFORE FIRING										DAY SIX																										
ZERO				+ WIND = 										HOLD																										
		HOLDS IN INCHES		<table border="1" style="font-size: 8px;"> <tr> <th>VALUE</th> <th>5mph M16A4</th> <th>M4</th> <th>10mph M16A4</th> <th>M4</th> <th>15mph M16A4</th> <th>M4</th> <th>20mph M16A4</th> <th>M4</th> <th>25mph M16A4</th> <th>M4</th> </tr> <tr> <td>FULL</td> <td>2</td> <td>3</td> <td>5</td> <td>5</td> <td>7</td> <td>8</td> <td>9</td> <td>10</td> <td>11</td> <td>19</td> </tr> <tr> <td>HALF</td> <td>1</td> <td>1</td> <td>2</td> <td>2</td> <td>3</td> <td>4</td> <td>4</td> <td>5</td> <td>5</td> <td>9</td> </tr> </table>		VALUE	5mph M16A4	M4	10mph M16A4	M4	15mph M16A4	M4	20mph M16A4	M4	25mph M16A4	M4	FULL	2	3	5	5	7	8	9	10	11	19	HALF	1	1	2	2	3	4	4	5	5	9		
VALUE	5mph M16A4	M4	10mph M16A4	M4	15mph M16A4	M4	20mph M16A4	M4	25mph M16A4	M4																														
FULL	2	3	5	5	7	8	9	10	11	19																														
HALF	1	1	2	2	3	4	4	5	5	9																														
<b>WEATHER DATA</b>				<b>PLOT</b>										<b>AFTER FIRING</b>																										
LIGHT <input type="checkbox"/> OVERCAST <input type="checkbox"/> PARTLY CLOUDY <input type="checkbox"/> CLEAR				PRECIP <input type="checkbox"/> DRY <input type="checkbox"/> LT RAIN <input type="checkbox"/> MIST <input type="checkbox"/> HVY RAIN												<b>SIGHT PICTURE ADJUSTMENT (WITHOUT WIND)</b>																								
<b>DURING FIRING</b>				<b>REMARKS</b>																																				
1	2	3	4	5	6	7	8	9	10	11	12	13	14	15	16	17	18	19	20																					

**200 YARD RAPID-FIRE**

**BEFORE FIRING**

**DAY SIX**

ZERO

+ WIND =

HOLD

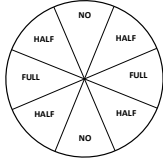

HOLDS IN INCHES

VALUE	5mph		10mph		15mph		20mph		25mph	
	M16A4	M4	M16A4	M4	M16A4	M4	M16A4	M4	M16A4	M4
FULL	2	3	5	5	7	8	9	10	11	19
HALF	1	1	2	2	3	4	4	5	5	9



**WEATHER DATA**

LIGHT

- OVERCAST
- PARTLY CLOUDY
- CLEAR
- DRY     LT RAIN
- MIST    HVY RAIN

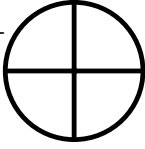

**REMARKS**

**AFTER FIRING**

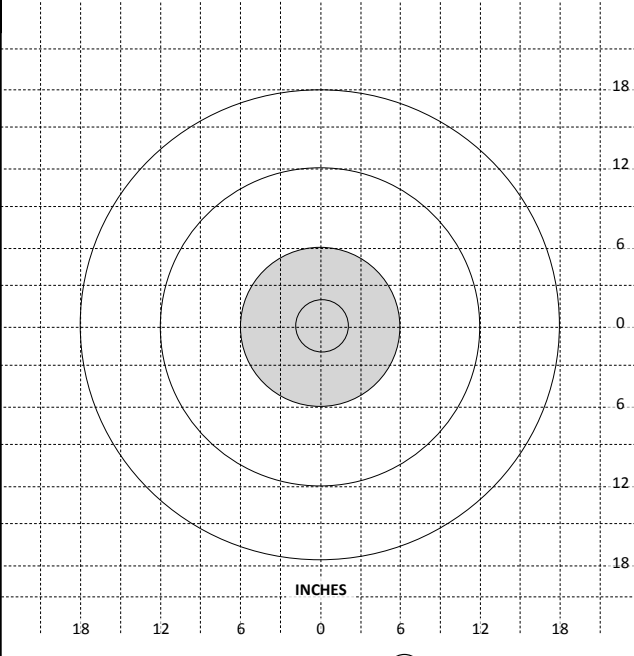

**200 YARD RAPID-FIRE**

**BEFORE FIRING**

**DAY SIX**

ZERO

+ WIND =

HOLD

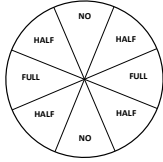

HOLDS IN INCHES

VALUE	5mph		10mph		15mph		20mph		25mph	
	M16A4	M4	M16A4	M4	M16A4	M4	M16A4	M4	M16A4	M4
FULL	2	3	5	5	7	8	9	10	11	19
HALF	1	1	2	2	3	4	4	5	5	9



**WEATHER DATA**

LIGHT

- OVERCAST
- PARTLY CLOUDY
- CLEAR
- DRY     LT RAIN
- MIST    HVY RAIN

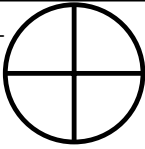

**REMARKS**

**AFTER FIRING**

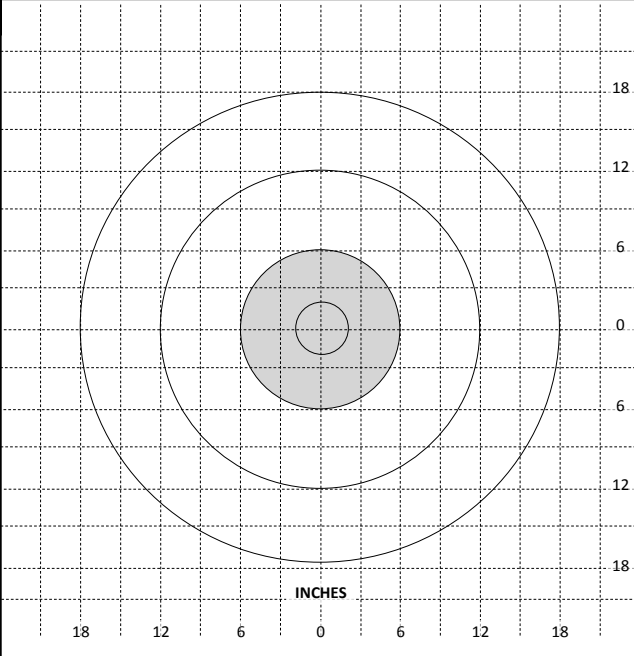

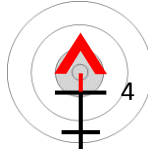
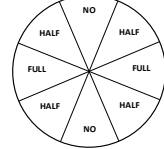

**ZERO** **+ WIND =** **HOLD**

HOLDS IN INCHES

VALUE	5mph		10mph		15mph		20mph		25mph	
	M16A4	M4	M16A4	M4	M16A4	M4	M16A4	M4	M16A4	M4
FULL	5	6	11	13	16	18	22	25	27	32
HALF	2	3	5	6	8	9	11	12	13	16



**WEATHER DATA**

LIGHT

OVERCAST

PARTLY CLOUDY

CLEAR

DRY  LT RAIN

MIST  HVY RAIN

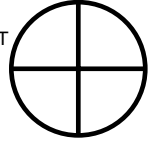
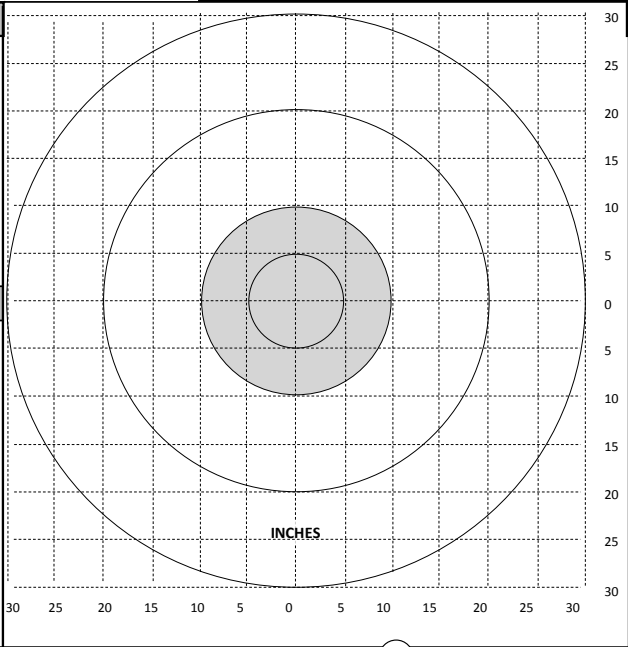
**REMARKS**

**ZERO** **+ WIND =** **HOLD**

HOLDS IN INCHES

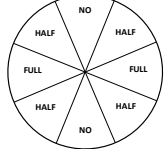
VALUE	5mph		10mph		15mph		20mph		25mph	
	M16A4	M4	M16A4	M4	M16A4	M4	M16A4	M4	M16A4	M4
FULL	5	6	11	13	16	18	22	25	27	32
HALF	2	3	5	6	8	9	11	12	13	16



**WEATHER DATA**

LIGHT

OVERCAST

PARTLY CLOUDY

CLEAR

DRY  LT RAIN

MIST  HVY RAIN

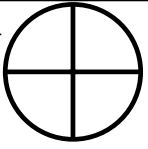
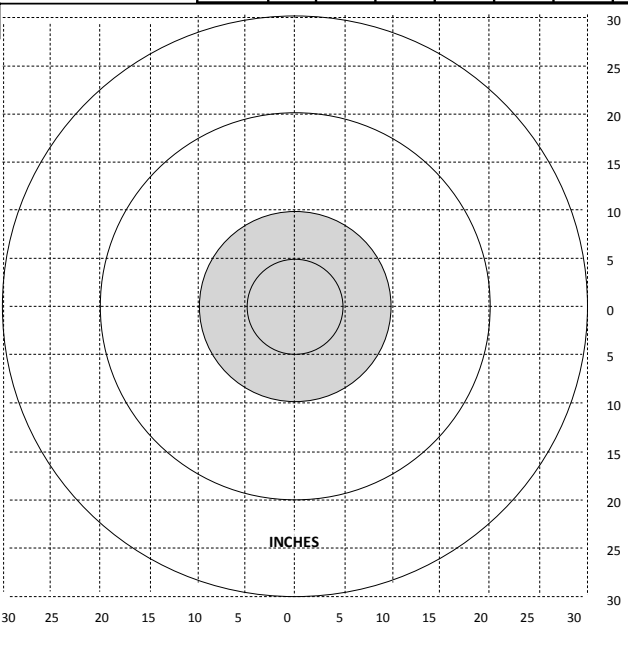
**REMARKS**

**500 YARD SLOW-FIRE** **BEFORE FIRING** **DAY SIX**

**ZERO** **+ WIND =** **HOLD**

HOLDS IN INCHES

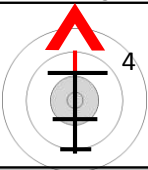
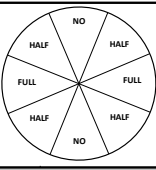
VALUE	5mph		10mph		15mph		20mph		25mph	
	M16A4	M4	M16A4	M4	M16A4	M4	M16A4	M4	M16A4	M4
FULL	17	20	35	40	52	60	69	81	87	101
HALF	8	10	17	20	26	30	34	40	43	50

**WEATHER DATA**

LIGHT

OVERCAST

PARTLY CLOUDY

CLEAR

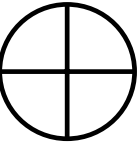

PRECIP

DRY

LT RAIN

MIST

HVY RAIN

**DURING FIRING**

1	2	3	4
5	6	7	8
9	10	11	12
13	14	15	16
17	18	19	20

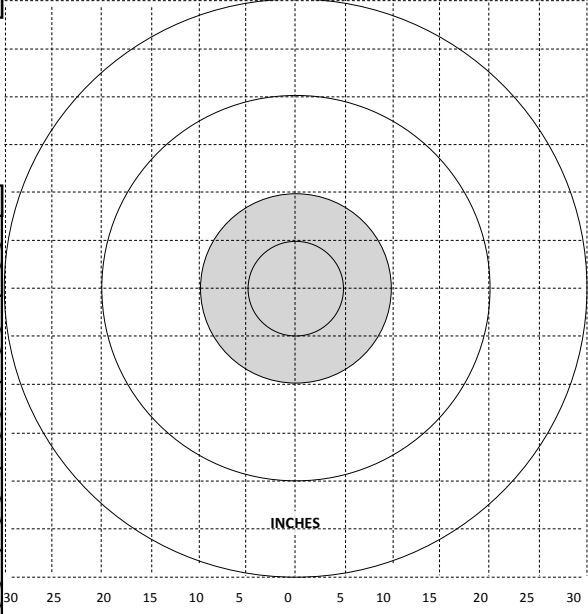

**AFTER FIRING**

**REMARKS**

**500 YARD SLOW-FIRE** **BEFORE FIRING** **DAY SIX**

**ZERO** **+ WIND =** **HOLD**

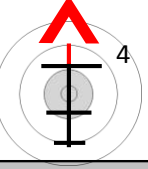
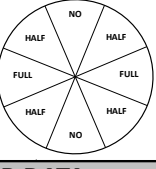
HOLDS IN INCHES

VALUE	5mph		10mph		15mph		20mph		25mph	
	M16A4	M4	M16A4	M4	M16A4	M4	M16A4	M4	M16A4	M4
FULL	17	20	35	40	52	60	69	81	87	101
HALF	8	10	17	20	26	30	34	40	43	50

**WEATHER DATA**

LIGHT

OVERCAST

PARTLY CLOUDY

CLEAR

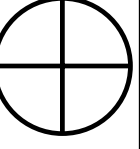

PRECIP

DRY

LT RAIN

MIST

HVY RAIN



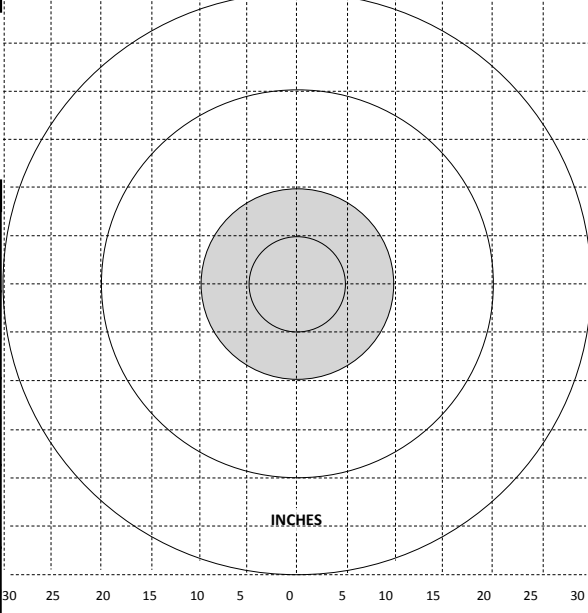

**DURING FIRING**



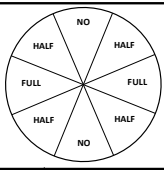

1	2	3	4
5	6	7	8
9	10	11	12
13	14	15	16
17	18	19	20

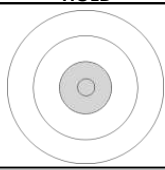
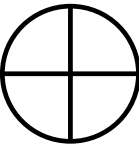
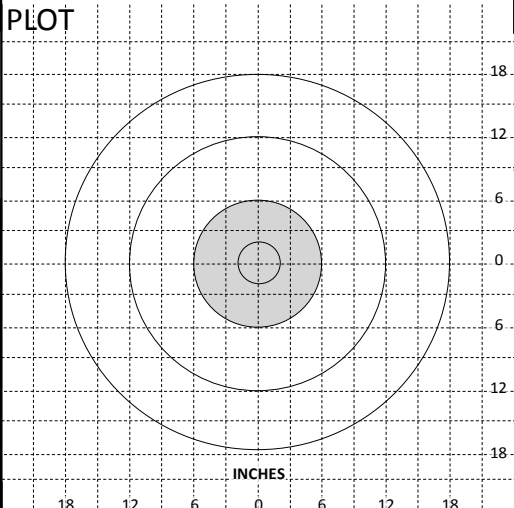



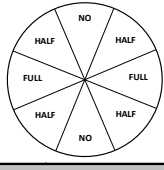

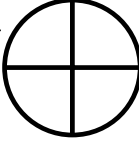
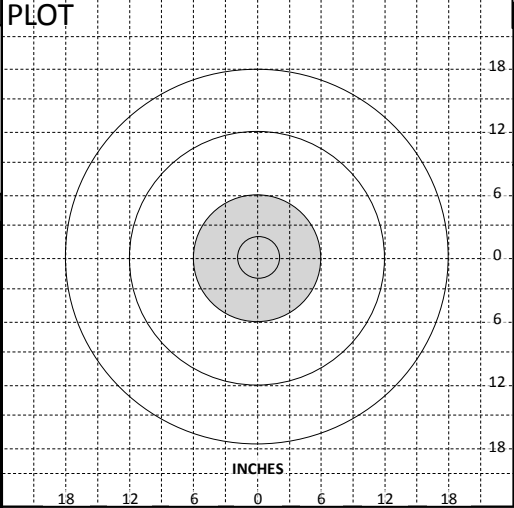

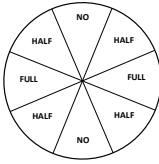

**AFTER FIRING**

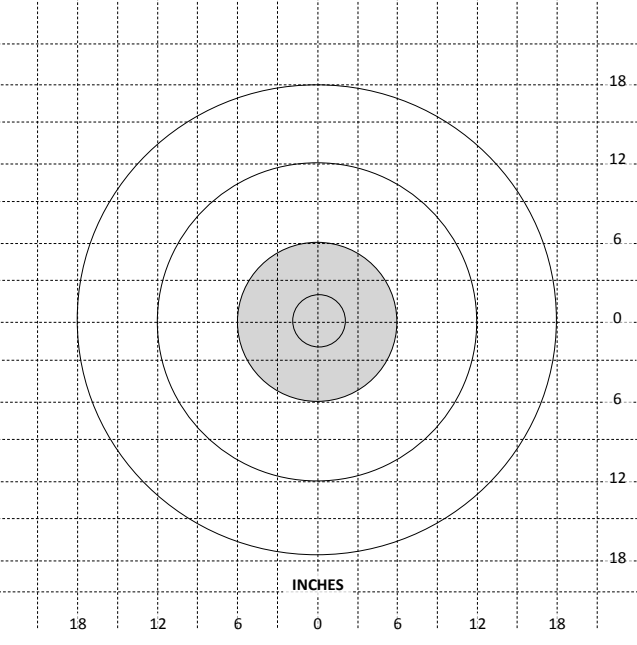
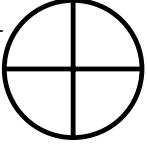

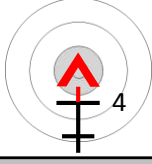
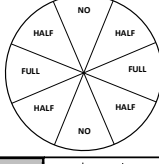

**REMARKS**

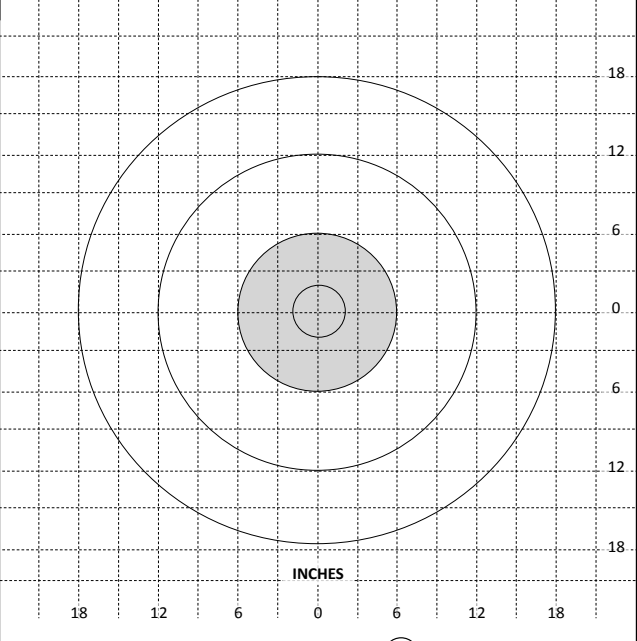
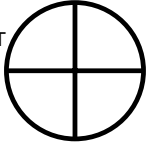

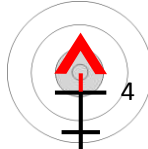
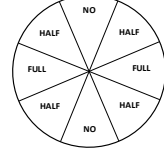

200 YARD SLOW-FIRE				BEFORE FIRING										DAY SEVEN																																					
ZERO				+ WIND =										HOLD																																					
				HOLDS IN INCHES 																																															
				<table border="1" style="font-size: small;"> <thead> <tr> <th>VALUE</th> <th colspan="2">5mph</th> <th colspan="2">10mph</th> <th colspan="2">15mph</th> <th colspan="2">20mph</th> <th colspan="2">25mph</th> </tr> <tr> <td></td> <td>M16A4</td> <td>M4</td> <td>M16A4</td> <td>M4</td> <td>M16A4</td> <td>M4</td> <td>M16A4</td> <td>M4</td> <td>M16A4</td> <td>M4</td> </tr> </thead> <tbody> <tr> <td>FULL</td> <td>2</td> <td>3</td> <td>5</td> <td>5</td> <td>7</td> <td>8</td> <td>9</td> <td>10</td> <td>11</td> <td>19</td> </tr> <tr> <td>HALF</td> <td>1</td> <td>1</td> <td>2</td> <td>2</td> <td>3</td> <td>4</td> <td>4</td> <td>5</td> <td>5</td> <td>9</td> </tr> </tbody> </table>		VALUE	5mph		10mph		15mph		20mph		25mph			M16A4	M4	M16A4	M4	M16A4	M4	M16A4	M4	M16A4	M4	FULL	2	3	5	5	7	8	9	10	11	19	HALF	1	1	2	2	3	4	4	5	5	9		
VALUE	5mph		10mph		15mph		20mph		25mph																																										
	M16A4	M4	M16A4	M4	M16A4	M4	M16A4	M4	M16A4	M4																																									
FULL	2	3	5	5	7	8	9	10	11	19																																									
HALF	1	1	2	2	3	4	4	5	5	9																																									
<b>WEATHER DATA</b>				<b>PLOT</b>										<b>AFTER FIRING</b>																																					
LIGHT <input type="checkbox"/> OVERCAST <input type="checkbox"/> PARTLY CLOUDY <input type="checkbox"/> CLEAR				PRECIP <input type="checkbox"/> DRY <input type="checkbox"/> LT RAIN <input type="checkbox"/> MIST <input type="checkbox"/> HVY RAIN												<b>SIGHT PICTURE ADJUSTMENT (WITHOUT WIND)</b>																																			
<b>DURING FIRING</b>				<b>REMARKS</b>																																															
1	2	3	4	5	6	7	8	9	10	11	12	13	14	15	16	17	18	19	20																																

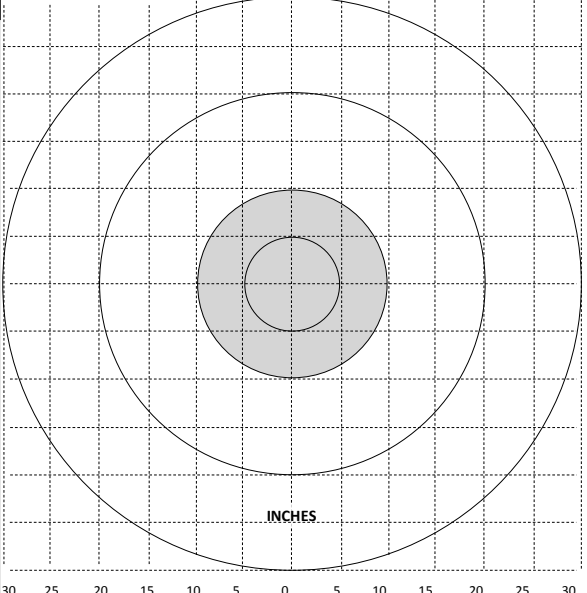

200 YARD SLOW-FIRE				BEFORE FIRING										DAY SEVEN																																					
ZERO				+ WIND =										HOLD																																					
				HOLDS IN INCHES 																																															
				<table border="1" style="font-size: small;"> <thead> <tr> <th>VALUE</th> <th colspan="2">5mph</th> <th colspan="2">10mph</th> <th colspan="2">15mph</th> <th colspan="2">20mph</th> <th colspan="2">25mph</th> </tr> <tr> <td></td> <td>M16A4</td> <td>M4</td> <td>M16A4</td> <td>M4</td> <td>M16A4</td> <td>M4</td> <td>M16A4</td> <td>M4</td> <td>M16A4</td> <td>M4</td> </tr> </thead> <tbody> <tr> <td>FULL</td> <td>2</td> <td>3</td> <td>5</td> <td>5</td> <td>7</td> <td>8</td> <td>9</td> <td>10</td> <td>11</td> <td>19</td> </tr> <tr> <td>HALF</td> <td>1</td> <td>1</td> <td>2</td> <td>2</td> <td>3</td> <td>4</td> <td>4</td> <td>5</td> <td>5</td> <td>9</td> </tr> </tbody> </table>		VALUE	5mph		10mph		15mph		20mph		25mph			M16A4	M4	M16A4	M4	M16A4	M4	M16A4	M4	M16A4	M4	FULL	2	3	5	5	7	8	9	10	11	19	HALF	1	1	2	2	3	4	4	5	5	9		
VALUE	5mph		10mph		15mph		20mph		25mph																																										
	M16A4	M4	M16A4	M4	M16A4	M4	M16A4	M4	M16A4	M4																																									
FULL	2	3	5	5	7	8	9	10	11	19																																									
HALF	1	1	2	2	3	4	4	5	5	9																																									
<b>WEATHER DATA</b>				<b>PLOT</b>										<b>AFTER FIRING</b>																																					
LIGHT <input type="checkbox"/> OVERCAST <input type="checkbox"/> PARTLY CLOUDY <input type="checkbox"/> CLEAR				PRECIP <input type="checkbox"/> DRY <input type="checkbox"/> LT RAIN <input type="checkbox"/> MIST <input type="checkbox"/> HVY RAIN												<b>SIGHT PICTURE ADJUSTMENT (WITHOUT WIND)</b>																																			
<b>DURING FIRING</b>				<b>REMARKS</b>																																															
1	2	3	4	5	6	7	8	9	10	11	12	13	14	15	16	17	18	19	20																																

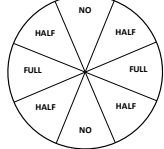

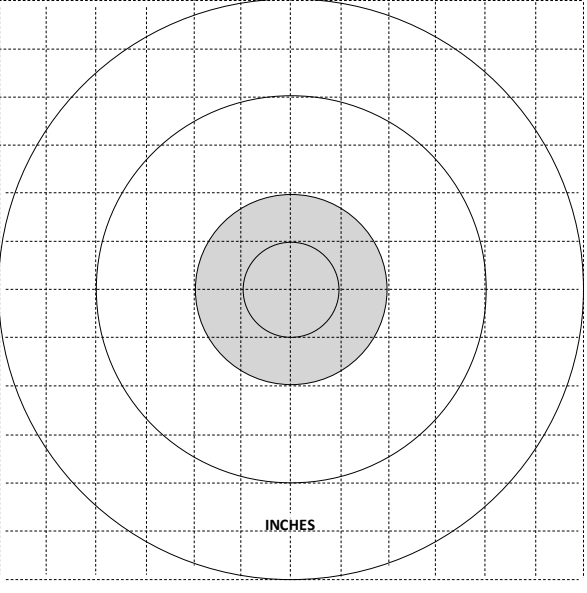
200 YARD RAPID-FIRE		BEFORE FIRING										DAY SEVEN																																					
ZERO		+ WIND =										HOLD																																					
		HOLDS IN INCHES 																																															
		<table border="1" style="font-size: small;"> <thead> <tr> <th>VALUE</th> <th colspan="2">5mph</th> <th colspan="2">10mph</th> <th colspan="2">15mph</th> <th colspan="2">20mph</th> <th colspan="2">25mph</th> </tr> <tr> <td></td> <th>M16A4</th> <th>M4</th> <th>M16A4</th> <th>M4</th> <th>M16A4</th> <th>M4</th> <th>M16A4</th> <th>M4</th> <th>M16A4</th> <th>M4</th> </tr> </thead> <tbody> <tr> <td>FULL</td> <td>2</td> <td>3</td> <td>5</td> <td>5</td> <td>7</td> <td>8</td> <td>9</td> <td>10</td> <td>11</td> <td>19</td> </tr> <tr> <td>HALF</td> <td>1</td> <td>1</td> <td>2</td> <td>2</td> <td>3</td> <td>4</td> <td>4</td> <td>5</td> <td>5</td> <td>9</td> </tr> </tbody> </table>		VALUE	5mph		10mph		15mph		20mph		25mph			M16A4	M4	M16A4	M4	M16A4	M4	M16A4	M4	M16A4	M4	FULL	2	3	5	5	7	8	9	10	11	19	HALF	1	1	2	2	3	4	4	5	5	9		
VALUE	5mph		10mph		15mph		20mph		25mph																																								
	M16A4	M4	M16A4	M4	M16A4	M4	M16A4	M4	M16A4	M4																																							
FULL	2	3	5	5	7	8	9	10	11	19																																							
HALF	1	1	2	2	3	4	4	5	5	9																																							
<b>WEATHER DATA</b>												<b>REMARKS</b>																																					
LIGHT <input type="checkbox"/> OVERCAST  <input type="checkbox"/> PARTLY CLOUDY <input type="checkbox"/> CLEAR <input type="checkbox"/> DRY <input type="checkbox"/> LT RAIN <input type="checkbox"/> MIST <input type="checkbox"/> HVY RAIN												<b>AFTER FIRING</b>																																					

200 YARD RAPID-FIRE		BEFORE FIRING										DAY SEVEN																																					
ZERO		+ WIND =										HOLD																																					
		HOLDS IN INCHES 																																															
		<table border="1" style="font-size: small;"> <thead> <tr> <th>VALUE</th> <th colspan="2">5mph</th> <th colspan="2">10mph</th> <th colspan="2">15mph</th> <th colspan="2">20mph</th> <th colspan="2">25mph</th> </tr> <tr> <td></td> <th>M16A4</th> <th>M4</th> <th>M16A4</th> <th>M4</th> <th>M16A4</th> <th>M4</th> <th>M16A4</th> <th>M4</th> <th>M16A4</th> <th>M4</th> </tr> </thead> <tbody> <tr> <td>FULL</td> <td>2</td> <td>3</td> <td>5</td> <td>5</td> <td>7</td> <td>8</td> <td>9</td> <td>10</td> <td>11</td> <td>19</td> </tr> <tr> <td>HALF</td> <td>1</td> <td>1</td> <td>2</td> <td>2</td> <td>3</td> <td>4</td> <td>4</td> <td>5</td> <td>5</td> <td>9</td> </tr> </tbody> </table>		VALUE	5mph		10mph		15mph		20mph		25mph			M16A4	M4	M16A4	M4	M16A4	M4	M16A4	M4	M16A4	M4	FULL	2	3	5	5	7	8	9	10	11	19	HALF	1	1	2	2	3	4	4	5	5	9		
VALUE	5mph		10mph		15mph		20mph		25mph																																								
	M16A4	M4	M16A4	M4	M16A4	M4	M16A4	M4	M16A4	M4																																							
FULL	2	3	5	5	7	8	9	10	11	19																																							
HALF	1	1	2	2	3	4	4	5	5	9																																							
<b>WEATHER DATA</b>												<b>REMARKS</b>																																					
LIGHT <input type="checkbox"/> OVERCAST  <input type="checkbox"/> PARTLY CLOUDY <input type="checkbox"/> CLEAR <input type="checkbox"/> DRY <input type="checkbox"/> LT RAIN <input type="checkbox"/> MIST <input type="checkbox"/> HVY RAIN												<b>AFTER FIRING</b>																																					

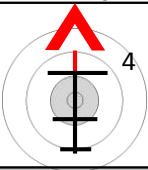
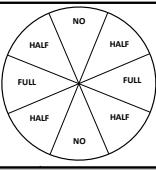
<b>300 YARD RAPID-FIRE</b>		<b>BEFORE FIRING</b>										<b>DAY SEVEN</b>																																							
ZERO		+ WIND =										HOLD																																							
				HOLDS IN INCHES 																																															
				<table border="1" style="font-size: small;"> <thead> <tr> <th>VALUE</th> <th colspan="2">5mph</th> <th colspan="2">10mph</th> <th colspan="2">15mph</th> <th colspan="2">20mph</th> <th colspan="2">25mph</th> </tr> <tr> <th></th> <th>M16A4</th> <th>M4</th> <th>M16A4</th> <th>M4</th> <th>M16A4</th> <th>M4</th> <th>M16A4</th> <th>M4</th> <th>M16A4</th> <th>M4</th> </tr> </thead> <tbody> <tr> <td>FULL</td> <td>5</td> <td>6</td> <td>11</td> <td>13</td> <td>16</td> <td>18</td> <td>22</td> <td>25</td> <td>27</td> <td>32</td> </tr> <tr> <td>HALF</td> <td>2</td> <td>3</td> <td>5</td> <td>6</td> <td>8</td> <td>9</td> <td>11</td> <td>12</td> <td>13</td> <td>16</td> </tr> </tbody> </table>		VALUE	5mph		10mph		15mph		20mph		25mph			M16A4	M4	M16A4	M4	M16A4	M4	M16A4	M4	M16A4	M4	FULL	5	6	11	13	16	18	22	25	27	32	HALF	2	3	5	6	8	9	11	12	13	16		
VALUE	5mph		10mph		15mph		20mph		25mph																																										
	M16A4	M4	M16A4	M4	M16A4	M4	M16A4	M4	M16A4	M4																																									
FULL	5	6	11	13	16	18	22	25	27	32																																									
HALF	2	3	5	6	8	9	11	12	13	16																																									
<b>WEATHER DATA</b>												<b>REMARKS</b>																																							
LIGHT <input type="checkbox"/> OVERCAST <input type="checkbox"/> PARTLY CLOUDY <input type="checkbox"/> CLEAR <input type="checkbox"/> DRY <input type="checkbox"/> LT RAIN <input type="checkbox"/> MIST <input type="checkbox"/> HVY RAIN												<b>AFTER FIRING</b>																																							

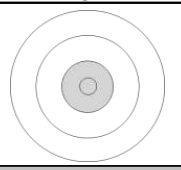
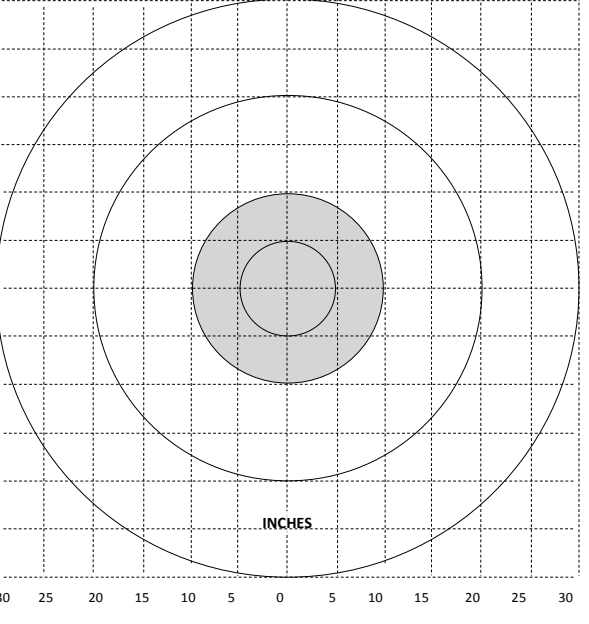
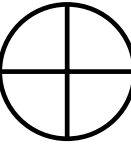
<b>300 YARD RAPID-FIRE</b>		<b>BEFORE FIRING</b>										<b>DAY SEVEN</b>																																							
ZERO		+ WIND =										HOLD																																							
				HOLDS IN INCHES 																																															
				<table border="1" style="font-size: small;"> <thead> <tr> <th>VALUE</th> <th colspan="2">5mph</th> <th colspan="2">10mph</th> <th colspan="2">15mph</th> <th colspan="2">20mph</th> <th colspan="2">25mph</th> </tr> <tr> <th></th> <th>M16A4</th> <th>M4</th> <th>M16A4</th> <th>M4</th> <th>M16A4</th> <th>M4</th> <th>M16A4</th> <th>M4</th> <th>M16A4</th> <th>M4</th> </tr> </thead> <tbody> <tr> <td>FULL</td> <td>5</td> <td>6</td> <td>11</td> <td>13</td> <td>16</td> <td>18</td> <td>22</td> <td>25</td> <td>27</td> <td>32</td> </tr> <tr> <td>HALF</td> <td>2</td> <td>3</td> <td>5</td> <td>6</td> <td>8</td> <td>9</td> <td>11</td> <td>12</td> <td>13</td> <td>16</td> </tr> </tbody> </table>		VALUE	5mph		10mph		15mph		20mph		25mph			M16A4	M4	M16A4	M4	M16A4	M4	M16A4	M4	M16A4	M4	FULL	5	6	11	13	16	18	22	25	27	32	HALF	2	3	5	6	8	9	11	12	13	16		
VALUE	5mph		10mph		15mph		20mph		25mph																																										
	M16A4	M4	M16A4	M4	M16A4	M4	M16A4	M4	M16A4	M4																																									
FULL	5	6	11	13	16	18	22	25	27	32																																									
HALF	2	3	5	6	8	9	11	12	13	16																																									
<b>WEATHER DATA</b>												<b>REMARKS</b>																																							
LIGHT <input type="checkbox"/> OVERCAST <input type="checkbox"/> PARTLY CLOUDY <input type="checkbox"/> CLEAR <input type="checkbox"/> DRY <input type="checkbox"/> LT RAIN <input type="checkbox"/> MIST <input type="checkbox"/> HVY RAIN												<b>AFTER FIRING</b>																																							

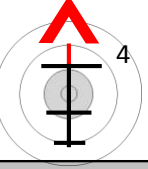
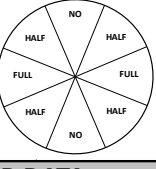
500 YARD SLOW-FIRE				BEFORE FIRING										DAY SEVEN																												
ZERO				+ WIND =										HOLD																												
				HOLDS IN INCHES 																																						
				<table border="1" style="font-size: small;"> <thead> <tr> <th>VALUE</th> <th>5mph M16A4</th> <th>M4</th> <th>10mph M16A4</th> <th>M4</th> <th>15mph M16A4</th> <th>M4</th> <th>20mph M16A4</th> <th>M4</th> <th>25mph M16A4</th> <th>M4</th> </tr> </thead> <tbody> <tr> <td>FULL</td> <td>17</td> <td>20</td> <td>35</td> <td>40</td> <td>52</td> <td>60</td> <td>69</td> <td>81</td> <td>87</td> <td>101</td> </tr> <tr> <td>HALF</td> <td>8</td> <td>10</td> <td>17</td> <td>20</td> <td>26</td> <td>30</td> <td>34</td> <td>40</td> <td>43</td> <td>50</td> </tr> </tbody> </table>		VALUE	5mph M16A4	M4	10mph M16A4	M4	15mph M16A4	M4	20mph M16A4	M4	25mph M16A4	M4	FULL	17	20	35	40	52	60	69	81	87	101	HALF	8	10	17	20	26	30	34	40	43	50				
VALUE	5mph M16A4	M4	10mph M16A4	M4	15mph M16A4	M4	20mph M16A4	M4	25mph M16A4	M4																																
FULL	17	20	35	40	52	60	69	81	87	101																																
HALF	8	10	17	20	26	30	34	40	43	50																																
WEATHER DATA														AFTER FIRING																												
LIGHT <input type="checkbox"/> OVERCAST <input type="checkbox"/> PARTLY CLOUDY <input type="checkbox"/> CLEAR														PRECIP <input type="checkbox"/> DRY <input type="checkbox"/> LT RAIN <input type="checkbox"/> MIST <input type="checkbox"/> HVY RAIN		REMARKS																										
DURING FIRING																																										
1	2	3	4	5	6	7	8	9	10	11	12	13	14	15	16	17	18	19	20																							

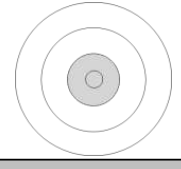
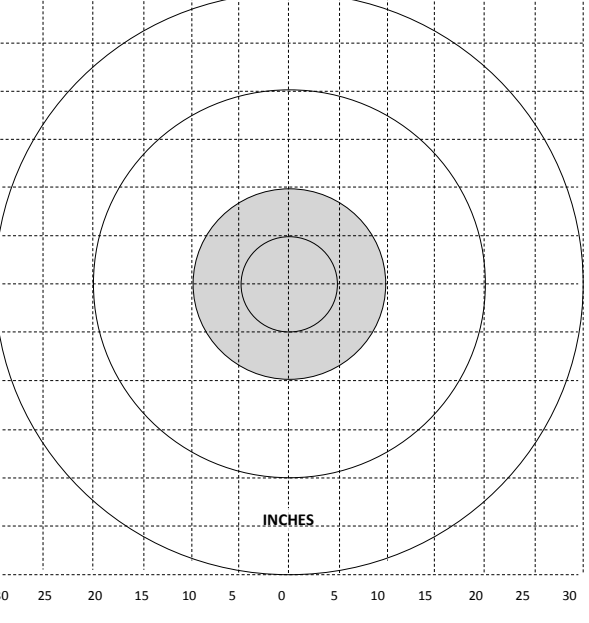
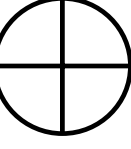
500 YARD SLOW-FIRE				BEFORE FIRING										DAY SEVEN																												
ZERO				+ WIND =										HOLD																												
				HOLDS IN INCHES 																																						
				<table border="1" style="font-size: small;"> <thead> <tr> <th>VALUE</th> <th>5mph M16A4</th> <th>M4</th> <th>10mph M16A4</th> <th>M4</th> <th>15mph M16A4</th> <th>M4</th> <th>20mph M16A4</th> <th>M4</th> <th>25mph M16A4</th> <th>M4</th> </tr> </thead> <tbody> <tr> <td>FULL</td> <td>17</td> <td>20</td> <td>35</td> <td>40</td> <td>52</td> <td>60</td> <td>69</td> <td>81</td> <td>87</td> <td>101</td> </tr> <tr> <td>HALF</td> <td>8</td> <td>10</td> <td>17</td> <td>20</td> <td>26</td> <td>30</td> <td>34</td> <td>40</td> <td>43</td> <td>50</td> </tr> </tbody> </table>		VALUE	5mph M16A4	M4	10mph M16A4	M4	15mph M16A4	M4	20mph M16A4	M4	25mph M16A4	M4	FULL	17	20	35	40	52	60	69	81	87	101	HALF	8	10	17	20	26	30	34	40	43	50				
VALUE	5mph M16A4	M4	10mph M16A4	M4	15mph M16A4	M4	20mph M16A4	M4	25mph M16A4	M4																																
FULL	17	20	35	40	52	60	69	81	87	101																																
HALF	8	10	17	20	26	30	34	40	43	50																																
WEATHER DATA														AFTER FIRING																												
LIGHT <input type="checkbox"/> OVERCAST <input type="checkbox"/> PARTLY CLOUDY <input type="checkbox"/> CLEAR														PRECIP <input type="checkbox"/> DRY <input type="checkbox"/> LT RAIN <input type="checkbox"/> MIST <input type="checkbox"/> HVY RAIN		REMARKS																										
DURING FIRING																																										
1	2	3	4	5	6	7	8	9	10	11	12	13	14	15	16	17	18	19	20																							

200 YARD SLOW-FIRE				BEFORE FIRING										DAY EIGHT																																									
ZERO				+ WIND = <table style="margin-left: auto; margin-right: auto;"> <tr> <td></td> <td></td> <td></td> <td></td> <td></td> <td></td> <td></td> <td></td> <td></td> <td></td> <td></td> <td></td> </tr> </table>																						HOLD																													
				HOLDS IN INCHES		<table border="1" style="font-size: small;"> <tr> <th>VALUE</th> <th colspan="2">5mph</th> <th colspan="2">10mph</th> <th colspan="2">15mph</th> <th colspan="2">20mph</th> <th colspan="2">25mph</th> </tr> <tr> <td></td> <td>M16A4</td> <td>M4</td> <td>M16A4</td> <td>M4</td> <td>M16A4</td> <td>M4</td> <td>M16A4</td> <td>M4</td> <td>M16A4</td> <td>M4</td> </tr> <tr> <td>FULL</td> <td>2</td> <td>3</td> <td>5</td> <td>5</td> <td>7</td> <td>8</td> <td>9</td> <td>10</td> <td>11</td> <td>19</td> </tr> <tr> <td>HALF</td> <td>1</td> <td>1</td> <td>2</td> <td>2</td> <td>3</td> <td>4</td> <td>4</td> <td>5</td> <td>5</td> <td>9</td> </tr> </table>		VALUE	5mph		10mph		15mph		20mph		25mph			M16A4	M4	M16A4	M4	M16A4	M4	M16A4	M4	M16A4	M4	FULL	2	3	5	5	7	8	9	10	11	19	HALF	1	1	2	2	3	4	4	5	5	9				
VALUE	5mph		10mph		15mph		20mph		25mph																																														
	M16A4	M4	M16A4	M4	M16A4	M4	M16A4	M4	M16A4	M4																																													
FULL	2	3	5	5	7	8	9	10	11	19																																													
HALF	1	1	2	2	3	4	4	5	5	9																																													
<b>WEATHER DATA</b>				<b>PLOT</b>										<b>AFTER FIRING</b>																																									
LIGHT <input type="checkbox"/> OVERCAST <input type="checkbox"/> PARTLY CLOUDY <input type="checkbox"/> CLEAR				PRECIP <input type="checkbox"/> DRY <input type="checkbox"/> LT RAIN <input type="checkbox"/> MIST <input type="checkbox"/> HVY RAIN												<b>SIGHT PICTURE ADJUSTMENT (WITHOUT WIND)</b>																																							
<b>DURING FIRING</b>				<b>REMARKS</b>																																																			
1	2	3	4	5	6	7	8	9	10	11	12	13	14	15	16	17	18	19	20																																				

200 YARD SLOW-FIRE				BEFORE FIRING										DAY EIGHT																																									
ZERO				+ WIND = <table style="margin-left: auto; margin-right: auto;"> <tr> <td></td> <td></td> <td></td> <td></td> <td></td> <td></td> <td></td> <td></td> <td></td> <td></td> <td></td> </tr> </table>																					HOLD																														
				HOLDS IN INCHES		<table border="1" style="font-size: small;"> <tr> <th>VALUE</th> <th colspan="2">5mph</th> <th colspan="2">10mph</th> <th colspan="2">15mph</th> <th colspan="2">20mph</th> <th colspan="2">25mph</th> </tr> <tr> <td></td> <td>M16A4</td> <td>M4</td> <td>M16A4</td> <td>M4</td> <td>M16A4</td> <td>M4</td> <td>M16A4</td> <td>M4</td> <td>M16A4</td> <td>M4</td> </tr> <tr> <td>FULL</td> <td>2</td> <td>3</td> <td>5</td> <td>5</td> <td>7</td> <td>8</td> <td>9</td> <td>10</td> <td>11</td> <td>19</td> </tr> <tr> <td>HALF</td> <td>1</td> <td>1</td> <td>2</td> <td>2</td> <td>3</td> <td>4</td> <td>4</td> <td>5</td> <td>5</td> <td>9</td> </tr> </table>		VALUE	5mph		10mph		15mph		20mph		25mph			M16A4	M4	M16A4	M4	M16A4	M4	M16A4	M4	M16A4	M4	FULL	2	3	5	5	7	8	9	10	11	19	HALF	1	1	2	2	3	4	4	5	5	9				
VALUE	5mph		10mph		15mph		20mph		25mph																																														
	M16A4	M4	M16A4	M4	M16A4	M4	M16A4	M4	M16A4	M4																																													
FULL	2	3	5	5	7	8	9	10	11	19																																													
HALF	1	1	2	2	3	4	4	5	5	9																																													
<b>WEATHER DATA</b>				<b>PLOT</b>										<b>AFTER FIRING</b>																																									
LIGHT <input type="checkbox"/> OVERCAST <input type="checkbox"/> PARTLY CLOUDY <input type="checkbox"/> CLEAR				PRECIP <input type="checkbox"/> DRY <input type="checkbox"/> LT RAIN <input type="checkbox"/> MIST <input type="checkbox"/> HVY RAIN												<b>SIGHT PICTURE ADJUSTMENT (WITHOUT WIND)</b>																																							
<b>DURING FIRING</b>				<b>REMARKS</b>																																																			
1	2	3	4	5	6	7	8	9	10	11	12	13	14	15	16	17	18	19	20																																				

200 YARD RAPID-FIRE		BEFORE FIRING										DAY EIGHT		
ZERO		+ WIND =										HOLD		
		HOLDS IN INCHES												
		5mph		10mph		15mph		20mph		25mph				
		VALUE	M16A4	M4	M16A4	M4	M16A4	M4	M16A4	M4	M16A4	M4		
		FULL	2	3	5	5	7	8	9	10	11	19		
		HALF	1	1	2	2	3	4	4	5	5	9		
WEATHER DATA												REMARKS		
LIGHT <input type="checkbox"/> OVERCAST <input type="checkbox"/> PARTLY CLOUDY <input type="checkbox"/> CLEAR <input type="checkbox"/> DRY <input type="checkbox"/> LT RAIN <input type="checkbox"/> MIST <input type="checkbox"/> HVY RAIN														
AFTER FIRING														

200 YARD RAPID-FIRE		BEFORE FIRING										DAY EIGHT		
ZERO		+ WIND =										HOLD		
		HOLDS IN INCHES												
		5mph		10mph		15mph		20mph		25mph				
		VALUE	M16A4	M4	M16A4	M4	M16A4	M4	M16A4	M4	M16A4	M4		
		FULL	2	3	5	5	7	8	9	10	11	19		
		HALF	1	1	2	2	3	4	4	5	5	9		
WEATHER DATA												REMARKS		
LIGHT <input type="checkbox"/> OVERCAST <input type="checkbox"/> PARTLY CLOUDY <input type="checkbox"/> CLEAR <input type="checkbox"/> DRY <input type="checkbox"/> LT RAIN <input type="checkbox"/> MIST <input type="checkbox"/> HVY RAIN														
AFTER FIRING														



**300 YARD RAPID-FIRE** **BEFORE FIRING** **DAY EIGHT**

**ZERO** **+ WIND =** **HOLD**

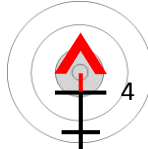
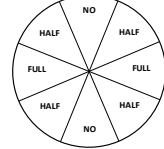
HOLDS IN INCHES

VALUE	5mph		10mph		15mph		20mph		25mph	
	M16A4	M4	M16A4	M4	M16A4	M4	M16A4	M4	M16A4	M4
FULL	5	6	11	13	16	18	22	25	27	32
HALF	2	3	5	6	8	9	11	12	13	16



**WEATHER DATA**

LIGHT

OVERCAST

PARTLY CLOUDY

CLEAR

DRY  LT RAIN

MIST  HVY RAIN

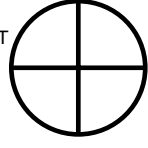
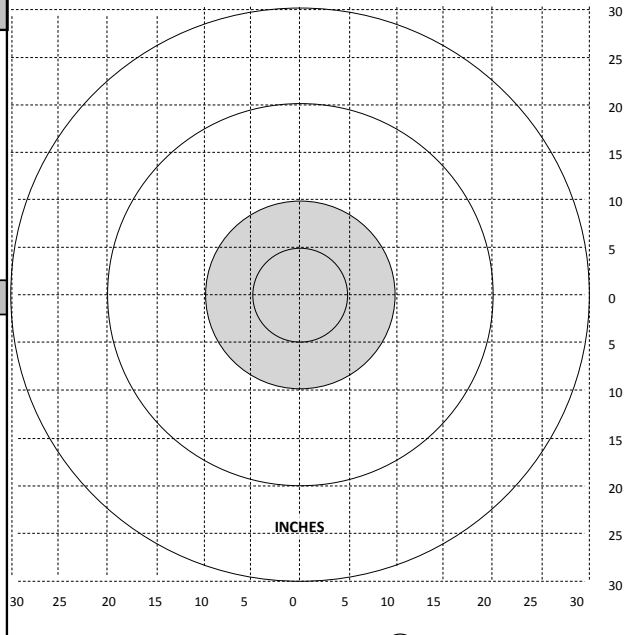
**REMARKS**

**300 YARD RAPID-FIRE** **BEFORE FIRING** **DAY EIGHT**

**ZERO** **+ WIND =** **HOLD**

HOLDS IN INCHES

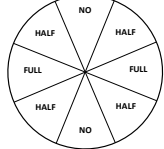
VALUE	5mph		10mph		15mph		20mph		25mph	
	M16A4	M4	M16A4	M4	M16A4	M4	M16A4	M4	M16A4	M4
FULL	5	6	11	13	16	18	22	25	27	32
HALF	2	3	5	6	8	9	11	12	13	16



**WEATHER DATA**

LIGHT

OVERCAST

PARTLY CLOUDY



CLEAR

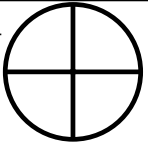
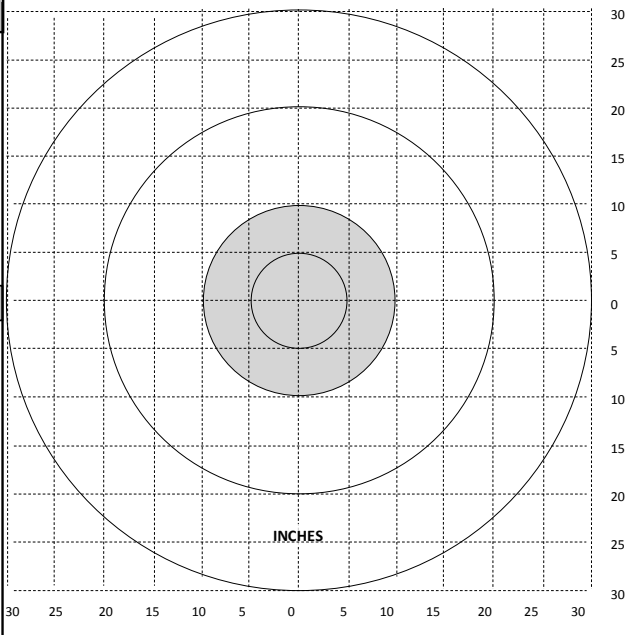

DRY  LT RAIN



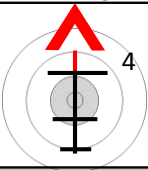
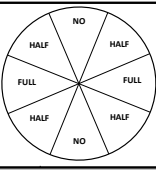

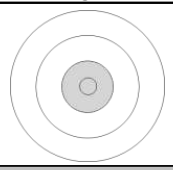
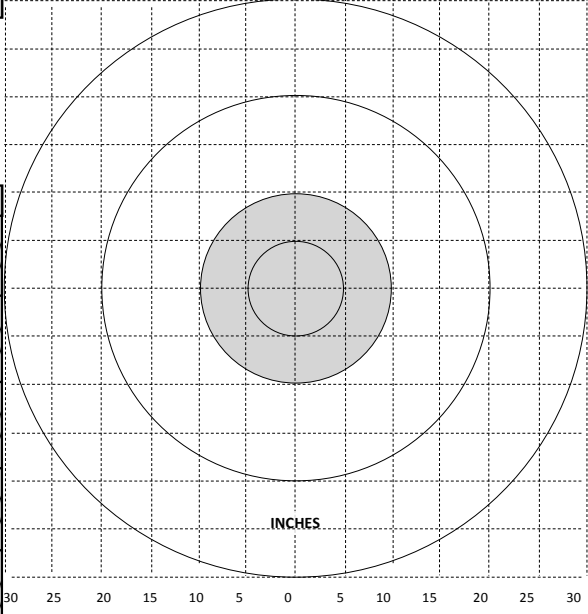
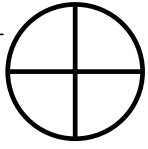
MIST  HVY RAIN

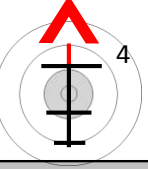
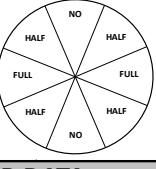

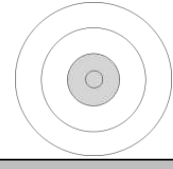
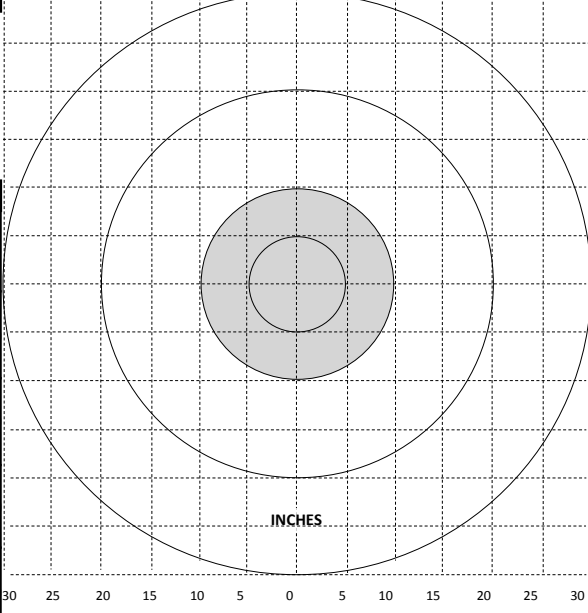
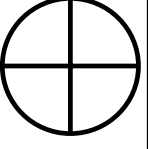

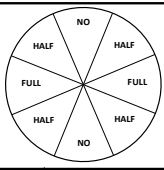

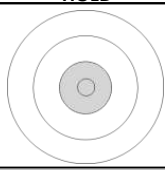
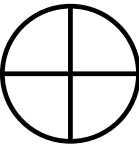
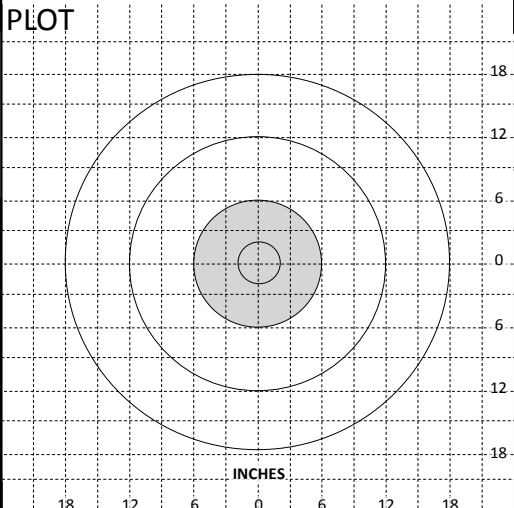



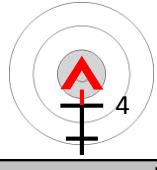
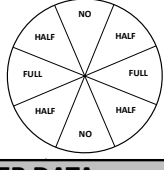

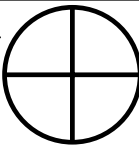
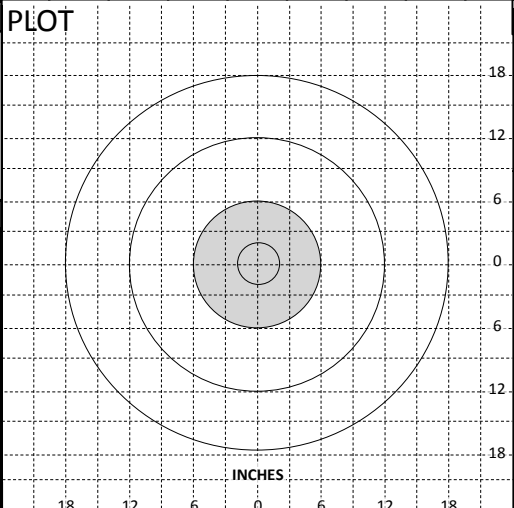
**REMARKS**



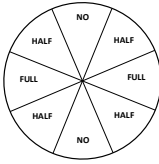

500 YARD SLOW-FIRE				BEFORE FIRING										DAY EIGHT																												
ZERO				+ WIND =										HOLD																												
				HOLDS IN INCHES 																																						
				<table border="1" style="font-size: small;"> <thead> <tr> <th>VALUE</th> <th>5mph M16A4</th> <th>M4</th> <th>10mph M16A4</th> <th>M4</th> <th>15mph M16A4</th> <th>M4</th> <th>20mph M16A4</th> <th>M4</th> <th>25mph M16A4</th> <th>M4</th> </tr> </thead> <tbody> <tr> <td>FULL</td> <td>17</td> <td>20</td> <td>35</td> <td>40</td> <td>52</td> <td>60</td> <td>69</td> <td>81</td> <td>87</td> <td>101</td> </tr> <tr> <td>HALF</td> <td>8</td> <td>10</td> <td>17</td> <td>20</td> <td>26</td> <td>30</td> <td>34</td> <td>40</td> <td>43</td> <td>50</td> </tr> </tbody> </table>		VALUE	5mph M16A4	M4	10mph M16A4	M4	15mph M16A4	M4	20mph M16A4	M4	25mph M16A4	M4	FULL	17	20	35	40	52	60	69	81	87	101	HALF	8	10	17	20	26	30	34	40	43	50				
VALUE	5mph M16A4	M4	10mph M16A4	M4	15mph M16A4	M4	20mph M16A4	M4	25mph M16A4	M4																																
FULL	17	20	35	40	52	60	69	81	87	101																																
HALF	8	10	17	20	26	30	34	40	43	50																																
WEATHER DATA														AFTER FIRING																												
LIGHT <input type="checkbox"/> OVERCAST <input type="checkbox"/> PARTLY CLOUDY <input type="checkbox"/> CLEAR														PRECIP <input type="checkbox"/> DRY <input type="checkbox"/> LT RAIN <input type="checkbox"/> MIST <input type="checkbox"/> HVY RAIN		REMARKS																										
DURING FIRING																																										
1	2	3	4	5	6	7	8	9	10	11	12	13	14	15	16	17	18	19	20																							

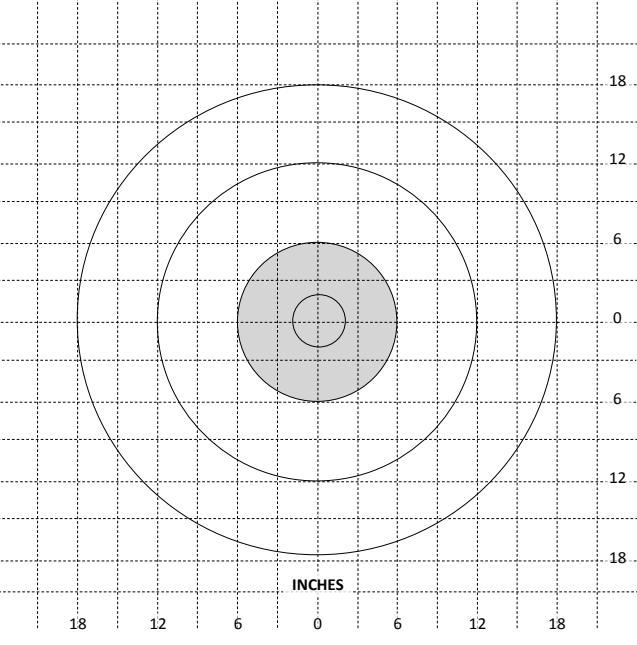
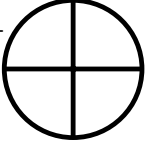
500 YARD SLOW-FIRE				BEFORE FIRING										DAY EIGHT																												
ZERO				+ WIND =										HOLD																												
				HOLDS IN INCHES 																																						
				<table border="1" style="font-size: small;"> <thead> <tr> <th>VALUE</th> <th>5mph M16A4</th> <th>M4</th> <th>10mph M16A4</th> <th>M4</th> <th>15mph M16A4</th> <th>M4</th> <th>20mph M16A4</th> <th>M4</th> <th>25mph M16A4</th> <th>M4</th> </tr> </thead> <tbody> <tr> <td>FULL</td> <td>17</td> <td>20</td> <td>35</td> <td>40</td> <td>52</td> <td>60</td> <td>69</td> <td>81</td> <td>87</td> <td>101</td> </tr> <tr> <td>HALF</td> <td>8</td> <td>10</td> <td>17</td> <td>20</td> <td>26</td> <td>30</td> <td>34</td> <td>40</td> <td>43</td> <td>50</td> </tr> </tbody> </table>		VALUE	5mph M16A4	M4	10mph M16A4	M4	15mph M16A4	M4	20mph M16A4	M4	25mph M16A4	M4	FULL	17	20	35	40	52	60	69	81	87	101	HALF	8	10	17	20	26	30	34	40	43	50				
VALUE	5mph M16A4	M4	10mph M16A4	M4	15mph M16A4	M4	20mph M16A4	M4	25mph M16A4	M4																																
FULL	17	20	35	40	52	60	69	81	87	101																																
HALF	8	10	17	20	26	30	34	40	43	50																																
WEATHER DATA														AFTER FIRING																												
LIGHT <input type="checkbox"/> OVERCAST <input type="checkbox"/> PARTLY CLOUDY <input type="checkbox"/> CLEAR														PRECIP <input type="checkbox"/> DRY <input type="checkbox"/> LT RAIN <input type="checkbox"/> MIST <input type="checkbox"/> HVY RAIN		REMARKS																										
DURING FIRING																																										
1	2	3	4	5	6	7	8	9	10	11	12	13	14	15	16	17	18	19	20																							

200 YARD SLOW-FIRE				BEFORE FIRING										DAY NINE							
ZERO				+ WIND =										HOLD							
				HOLDS IN INCHES 																	
				VALUE		5mph		10mph		15mph		20mph		25mph							
				M16A4		M4		M16A4		M4		M16A4		M4							
				FULL		2		3		5		5		7		8					
				HALF		1		1		2		2		3		4					
<b>WEATHER DATA</b>				<b>PLOT</b>														<b>AFTER FIRING</b>			
LIGHT <input type="checkbox"/> OVERCAST <input type="checkbox"/> PARTLY CLOUDY <input type="checkbox"/> CLEAR				PRECIP <input type="checkbox"/> DRY <input type="checkbox"/> LT RAIN <input type="checkbox"/> MIST <input type="checkbox"/> HVY RAIN																<b>SIGHT PICTURE ADJUSTMENT (WITHOUT WIND)</b>  	
<b>DURING FIRING</b>				REMARKS																	
1	2	3	4																		
5	6	7	8																		
9	10	11	12																		
13	14	15	16																		
17	18	19	20																		

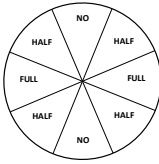
200 YARD SLOW-FIRE				BEFORE FIRING										DAY NINE							
ZERO				+ WIND =										HOLD							
				HOLDS IN INCHES 																	
				VALUE		5mph		10mph		15mph		20mph		25mph							
				M16A4		M4		M16A4		M4		M16A4		M4							
				FULL		2		3		5		5		7		8					
				HALF		1		1		2		2		3		4					
<b>WEATHER DATA</b>				<b>PLOT</b>														<b>AFTER FIRING</b>			
LIGHT <input type="checkbox"/> OVERCAST <input type="checkbox"/> PARTLY CLOUDY <input type="checkbox"/> CLEAR				PRECIP <input type="checkbox"/> DRY <input type="checkbox"/> LT RAIN <input type="checkbox"/> MIST <input type="checkbox"/> HVY RAIN																<b>SIGHT PICTURE ADJUSTMENT (WITHOUT WIND)</b>  	
<b>DURING FIRING</b>				REMARKS																	
1	2	3	4																		
5	6	7	8																		
9	10	11	12																		
13	14	15	16																		
17	18	19	20																		

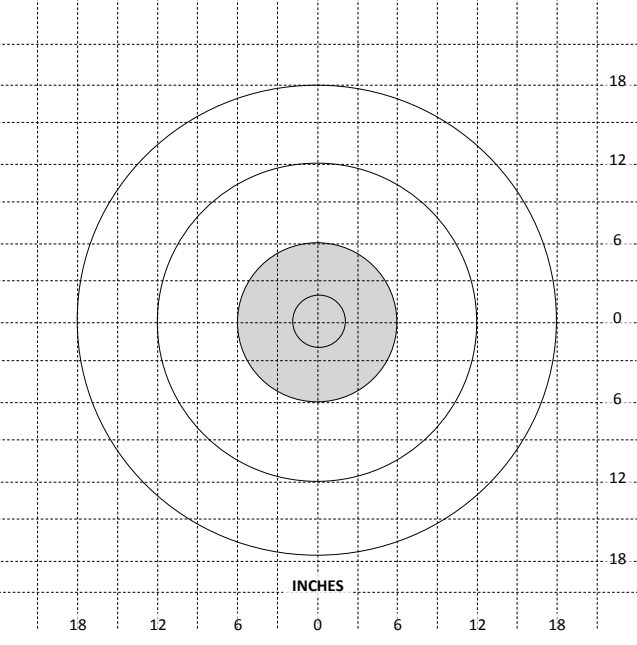
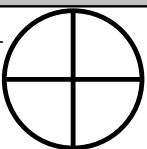
200 YARD RAPID-FIRE		BEFORE FIRING										DAY NINE																																					
ZERO		+ WIND =										HOLD																																					
		HOLDS IN INCHES 																																															
		<table border="1" style="font-size: small;"> <thead> <tr> <th>VALUE</th> <th colspan="2">5mph</th> <th colspan="2">10mph</th> <th colspan="2">15mph</th> <th colspan="2">20mph</th> <th colspan="2">25mph</th> </tr> <tr> <td></td> <th>M16A4</th> <th>M4</th> <th>M16A4</th> <th>M4</th> <th>M16A4</th> <th>M4</th> <th>M16A4</th> <th>M4</th> <th>M16A4</th> <th>M4</th> </tr> </thead> <tbody> <tr> <td>FULL</td> <td>2</td> <td>3</td> <td>5</td> <td>5</td> <td>7</td> <td>8</td> <td>9</td> <td>10</td> <td>11</td> <td>19</td> </tr> <tr> <td>HALF</td> <td>1</td> <td>1</td> <td>2</td> <td>2</td> <td>3</td> <td>4</td> <td>4</td> <td>5</td> <td>5</td> <td>9</td> </tr> </tbody> </table>		VALUE	5mph		10mph		15mph		20mph		25mph			M16A4	M4	M16A4	M4	M16A4	M4	M16A4	M4	M16A4	M4	FULL	2	3	5	5	7	8	9	10	11	19	HALF	1	1	2	2	3	4	4	5	5	9		
VALUE	5mph		10mph		15mph		20mph		25mph																																								
	M16A4	M4	M16A4	M4	M16A4	M4	M16A4	M4	M16A4	M4																																							
FULL	2	3	5	5	7	8	9	10	11	19																																							
HALF	1	1	2	2	3	4	4	5	5	9																																							
<b>WEATHER DATA</b>												<b>REMARKS</b>																																					
LIGHT <input type="checkbox"/> OVERCAST  <input type="checkbox"/> PARTLY CLOUDY <input type="checkbox"/> CLEAR <input type="checkbox"/> DRY <input type="checkbox"/> LT RAIN <input type="checkbox"/> MIST <input type="checkbox"/> HVY RAIN												<b>AFTER FIRING</b>																																					
		18   12   6   0   6   12   18																																															

200 YARD RAPID-FIRE		BEFORE FIRING										DAY NINE																																					
ZERO		+ WIND =										HOLD																																					
		HOLDS IN INCHES 																																															
		<table border="1" style="font-size: small;"> <thead> <tr> <th>VALUE</th> <th colspan="2">5mph</th> <th colspan="2">10mph</th> <th colspan="2">15mph</th> <th colspan="2">20mph</th> <th colspan="2">25mph</th> </tr> <tr> <td></td> <th>M16A4</th> <th>M4</th> <th>M16A4</th> <th>M4</th> <th>M16A4</th> <th>M4</th> <th>M16A4</th> <th>M4</th> <th>M16A4</th> <th>M4</th> </tr> </thead> <tbody> <tr> <td>FULL</td> <td>2</td> <td>3</td> <td>5</td> <td>5</td> <td>7</td> <td>8</td> <td>9</td> <td>10</td> <td>11</td> <td>19</td> </tr> <tr> <td>HALF</td> <td>1</td> <td>1</td> <td>2</td> <td>2</td> <td>3</td> <td>4</td> <td>4</td> <td>5</td> <td>5</td> <td>9</td> </tr> </tbody> </table>		VALUE	5mph		10mph		15mph		20mph		25mph			M16A4	M4	M16A4	M4	M16A4	M4	M16A4	M4	M16A4	M4	FULL	2	3	5	5	7	8	9	10	11	19	HALF	1	1	2	2	3	4	4	5	5	9		
VALUE	5mph		10mph		15mph		20mph		25mph																																								
	M16A4	M4	M16A4	M4	M16A4	M4	M16A4	M4	M16A4	M4																																							
FULL	2	3	5	5	7	8	9	10	11	19																																							
HALF	1	1	2	2	3	4	4	5	5	9																																							
<b>WEATHER DATA</b>												<b>REMARKS</b>																																					
LIGHT <input type="checkbox"/> OVERCAST  <input type="checkbox"/> PARTLY CLOUDY <input type="checkbox"/> CLEAR <input type="checkbox"/> DRY <input type="checkbox"/> LT RAIN <input type="checkbox"/> MIST <input type="checkbox"/> HVY RAIN												<b>AFTER FIRING</b>																																					
		18   12   6   0   6   12   18																																															

**300 YARD RAPID-FIRE** **BEFORE FIRING** **DAY NINE**

**ZERO** **+ WIND =** **HOLD**

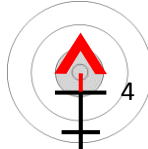
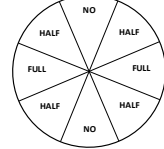
HOLDS IN INCHES

VALUE	5mph		10mph		15mph		20mph		25mph	
	M16A4	M4	M16A4	M4	M16A4	M4	M16A4	M4	M16A4	M4
FULL	5	6	11	13	16	18	22	25	27	32
HALF	2	3	5	6	8	9	11	12	13	16



**WEATHER DATA**

LIGHT

OVERCAST

PARTLY CLOUDY

CLEAR

DRY  LT RAIN

MIST  HVY RAIN

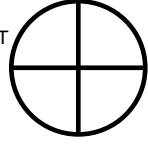
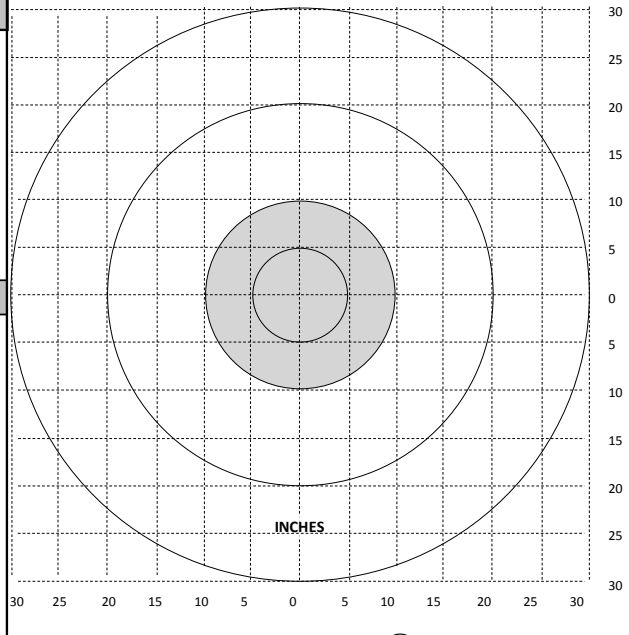
**REMARKS**

**300 YARD RAPID-FIRE** **BEFORE FIRING** **DAY NINE**

**ZERO** **+ WIND =** **HOLD**

HOLDS IN INCHES

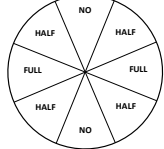
VALUE	5mph		10mph		15mph		20mph		25mph	
	M16A4	M4	M16A4	M4	M16A4	M4	M16A4	M4	M16A4	M4
FULL	5	6	11	13	16	18	22	25	27	32
HALF	2	3	5	6	8	9	11	12	13	16



**WEATHER DATA**

LIGHT

OVERCAST

PARTLY CLOUDY





CLEAR

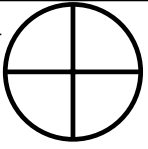
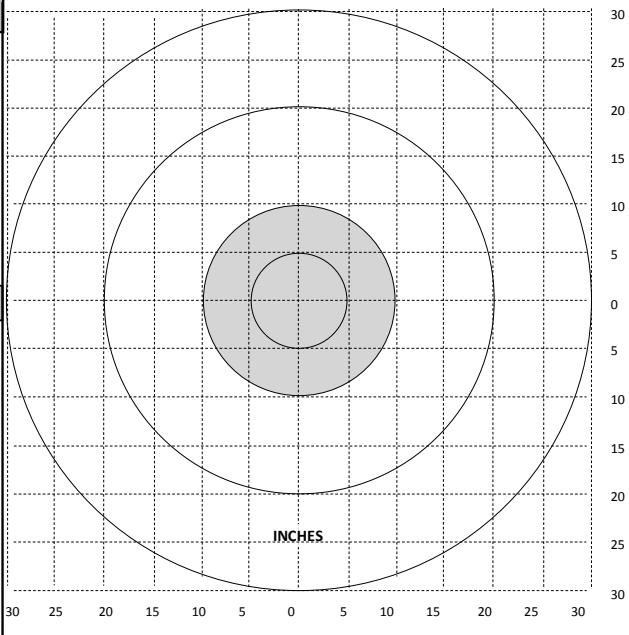

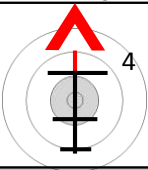
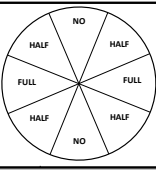

DRY  LT RAIN

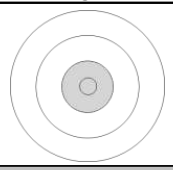
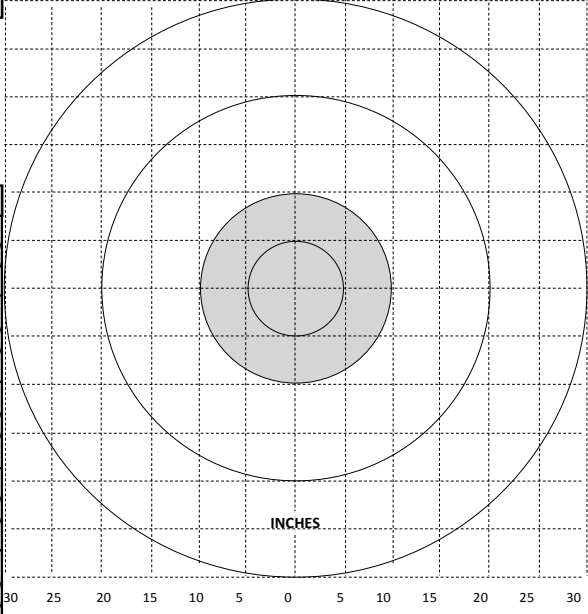

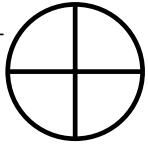
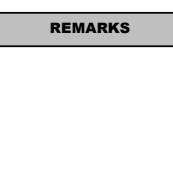
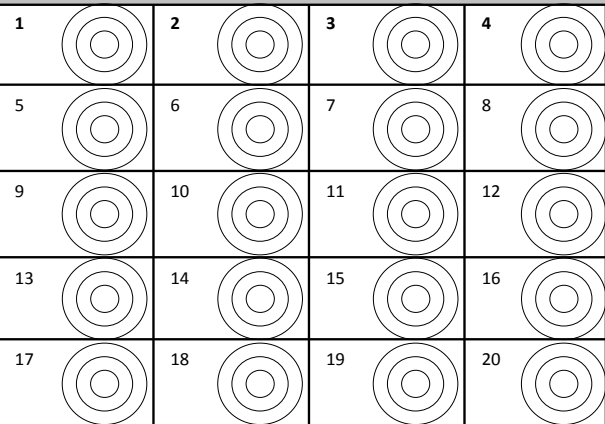

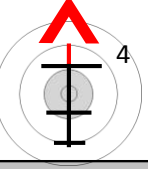
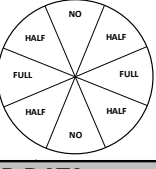

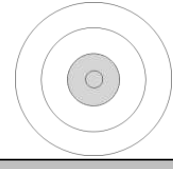
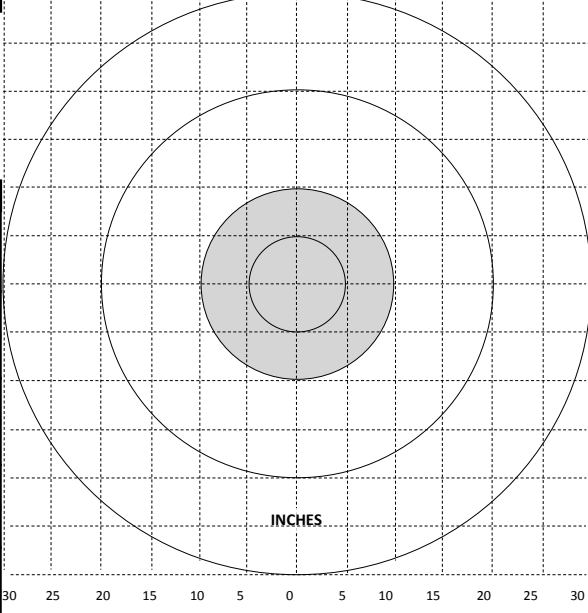

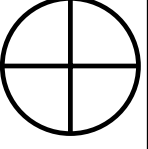
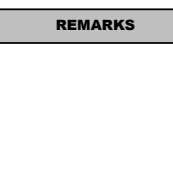
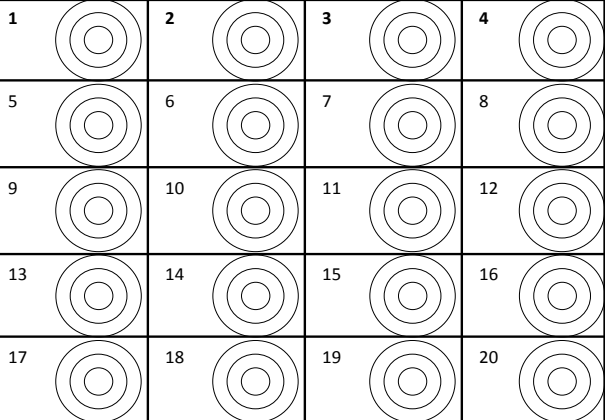
MIST  HVY RAIN

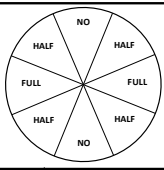





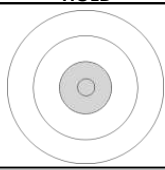
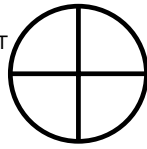
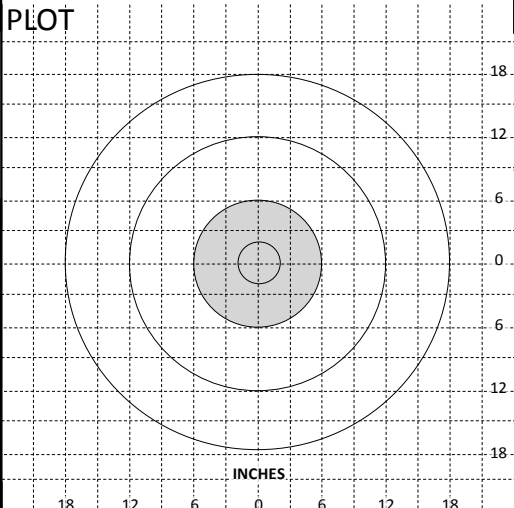



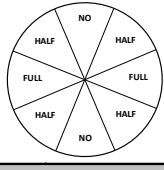



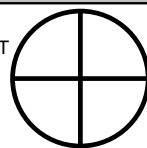
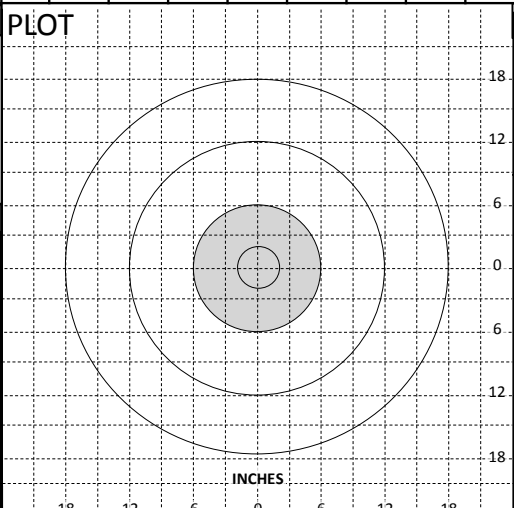

**REMARKS**



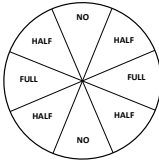

500 YARD SLOW-FIRE				BEFORE FIRING										DAY NINE																																							
ZERO				+ WIND =										HOLD																																							
				HOLDS IN INCHES 																																																	
				<table border="1" style="font-size: small;"> <thead> <tr> <th>VALUE</th> <th colspan="2">5mph</th> <th colspan="2">10mph</th> <th colspan="2">15mph</th> <th colspan="2">20mph</th> <th colspan="2">25mph</th> </tr> <tr> <th></th> <th>M16A4</th> <th>M4</th> <th>M16A4</th> <th>M4</th> <th>M16A4</th> <th>M4</th> <th>M16A4</th> <th>M4</th> <th>M16A4</th> <th>M4</th> </tr> </thead> <tbody> <tr> <td>FULL</td> <td>17</td> <td>20</td> <td>35</td> <td>40</td> <td>52</td> <td>60</td> <td>69</td> <td>81</td> <td>87</td> <td>101</td> </tr> <tr> <td>HALF</td> <td>8</td> <td>10</td> <td>17</td> <td>20</td> <td>26</td> <td>30</td> <td>34</td> <td>40</td> <td>43</td> <td>50</td> </tr> </tbody> </table>		VALUE	5mph		10mph		15mph		20mph		25mph			M16A4	M4	M16A4	M4	M16A4	M4	M16A4	M4	M16A4	M4	FULL	17	20	35	40	52	60	69	81	87	101	HALF	8	10	17	20	26	30	34	40	43	50				
VALUE	5mph		10mph		15mph		20mph		25mph																																												
	M16A4	M4	M16A4	M4	M16A4	M4	M16A4	M4	M16A4	M4																																											
FULL	17	20	35	40	52	60	69	81	87	101																																											
HALF	8	10	17	20	26	30	34	40	43	50																																											
WEATHER DATA																																																					
LIGHT <input type="checkbox"/> OVERCAST <input type="checkbox"/> PARTLY CLOUDY <input type="checkbox"/> CLEAR														PRECIP <input type="checkbox"/> DRY <input type="checkbox"/> LT RAIN <input type="checkbox"/> MIST <input type="checkbox"/> HVY RAIN																																							
DURING FIRING																																																					
1	2	3	4	5	6	7	8	9	10	11	12	13	14	15	16	17	18	19	20																																		
																																																					

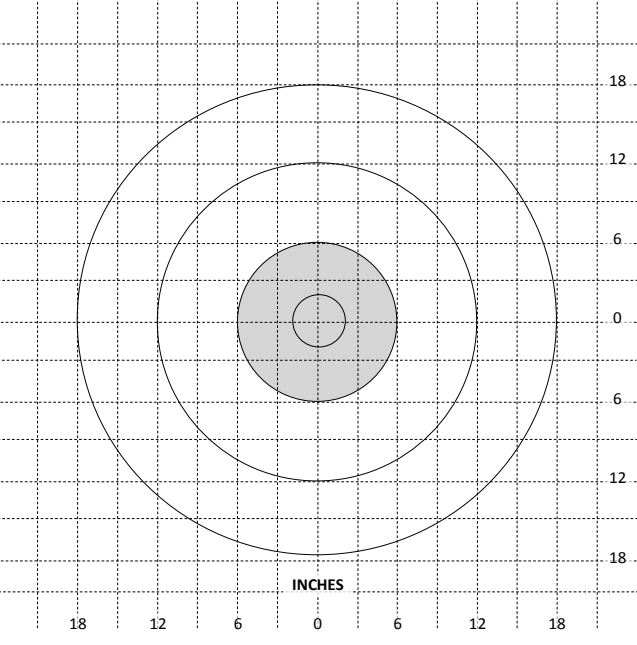
500 YARD SLOW-FIRE				BEFORE FIRING										DAY NINE																																							
ZERO				+ WIND =										HOLD																																							
				HOLDS IN INCHES 																																																	
				<table border="1" style="font-size: small;"> <thead> <tr> <th>VALUE</th> <th colspan="2">5mph</th> <th colspan="2">10mph</th> <th colspan="2">15mph</th> <th colspan="2">20mph</th> <th colspan="2">25mph</th> </tr> <tr> <th></th> <th>M16A4</th> <th>M4</th> <th>M16A4</th> <th>M4</th> <th>M16A4</th> <th>M4</th> <th>M16A4</th> <th>M4</th> <th>M16A4</th> <th>M4</th> </tr> </thead> <tbody> <tr> <td>FULL</td> <td>17</td> <td>20</td> <td>35</td> <td>40</td> <td>52</td> <td>60</td> <td>69</td> <td>81</td> <td>87</td> <td>101</td> </tr> <tr> <td>HALF</td> <td>8</td> <td>10</td> <td>17</td> <td>20</td> <td>26</td> <td>30</td> <td>34</td> <td>40</td> <td>43</td> <td>50</td> </tr> </tbody> </table>		VALUE	5mph		10mph		15mph		20mph		25mph			M16A4	M4	M16A4	M4	M16A4	M4	M16A4	M4	M16A4	M4	FULL	17	20	35	40	52	60	69	81	87	101	HALF	8	10	17	20	26	30	34	40	43	50				
VALUE	5mph		10mph		15mph		20mph		25mph																																												
	M16A4	M4	M16A4	M4	M16A4	M4	M16A4	M4	M16A4	M4																																											
FULL	17	20	35	40	52	60	69	81	87	101																																											
HALF	8	10	17	20	26	30	34	40	43	50																																											
WEATHER DATA																																																					
LIGHT <input type="checkbox"/> OVERCAST <input type="checkbox"/> PARTLY CLOUDY <input type="checkbox"/> CLEAR														PRECIP <input type="checkbox"/> DRY <input type="checkbox"/> LT RAIN <input type="checkbox"/> MIST <input type="checkbox"/> HVY RAIN																																							
DURING FIRING																																																					
1	2	3	4	5	6	7	8	9	10	11	12	13	14	15	16	17	18	19	20																																		
																																																					

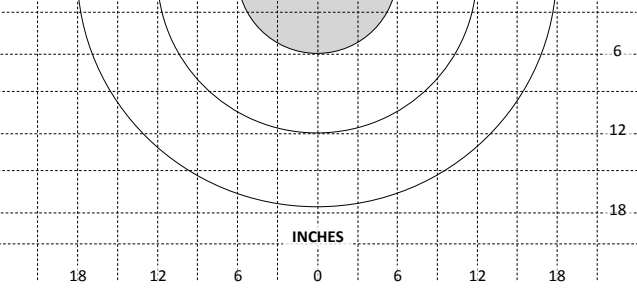
200 YARD SLOW-FIRE				BEFORE FIRING										DAY TEN			
ZERO				+ WIND =										HOLD			
				HOLDS IN INCHES													
				VALUE	5mph		10mph		15mph		20mph		25mph				
					M16A4	M4	M16A4	M4	M16A4	M4	M16A4	M4	M16A4	M4			
				FULL	2	3	5	5	7	8	9	10	11	19			
				HALF	1	1	2	2	3	4	4	5	5	9			
WEATHER DATA				PLOT										AFTER FIRING			
LIGHT <input type="checkbox"/> OVERCAST <input type="checkbox"/> PARTLY CLOUDY <input type="checkbox"/> CLEAR				PRECIP <input type="checkbox"/> DRY <input type="checkbox"/> LT RAIN <input type="checkbox"/> MIST <input type="checkbox"/> HVY RAIN												<b>SIGHT PICTURE ADJUSTMENT (WITHOUT WIND)</b>	
DURING FIRING				REMARKS													
1	2	3	4														
5	6	7	8														
9	10	11	12														
13	14	15	16														
17	18	19	20														

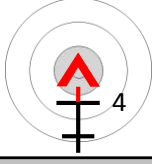
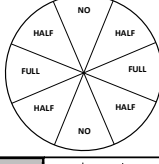
200 YARD SLOW-FIRE				BEFORE FIRING										DAY TEN			
ZERO				+ WIND =										HOLD			
				HOLDS IN INCHES													
				VALUE	5mph		10mph		15mph		20mph		25mph				
					M16A4	M4	M16A4	M4	M16A4	M4	M16A4	M4	M16A4	M4			
				FULL	2	3	5	5	7	8	9	10	11	19			
				HALF	1	1	2	2	3	4	4	5	5	9			
WEATHER DATA				PLOT										AFTER FIRING			
LIGHT <input type="checkbox"/> OVERCAST <input type="checkbox"/> PARTLY CLOUDY <input type="checkbox"/> CLEAR				PRECIP <input type="checkbox"/> DRY <input type="checkbox"/> LT RAIN <input type="checkbox"/> MIST <input type="checkbox"/> HVY RAIN												<b>SIGHT PICTURE ADJUSTMENT (WITHOUT WIND)</b>	
DURING FIRING				REMARKS													
1	2	3	4														
5	6	7	8														
9	10	11	12														
13	14	15	16														
17	18	19	20														

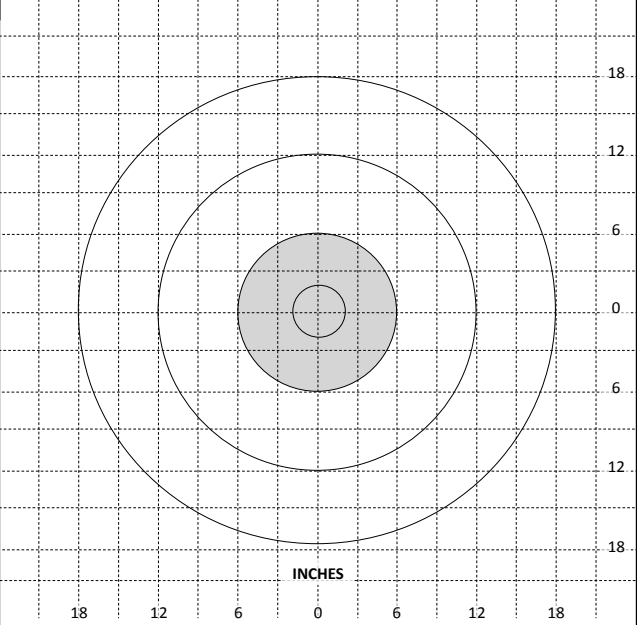
200 YARD RAPID-FIRE		BEFORE FIRING										DAY TEN																																					
ZERO		+ WIND =										HOLD																																					
		HOLDS IN INCHES 																																															
		<table border="1" style="font-size: small;"> <thead> <tr> <th>VALUE</th> <th colspan="2">5mph</th> <th colspan="2">10mph</th> <th colspan="2">15mph</th> <th colspan="2">20mph</th> <th colspan="2">25mph</th> </tr> <tr> <td></td> <th>M16A4</th> <th>M4</th> <th>M16A4</th> <th>M4</th> <th>M16A4</th> <th>M4</th> <th>M16A4</th> <th>M4</th> <th>M16A4</th> <th>M4</th> </tr> </thead> <tbody> <tr> <td>FULL</td> <td>2</td> <td>3</td> <td>5</td> <td>5</td> <td>7</td> <td>8</td> <td>9</td> <td>10</td> <td>11</td> <td>19</td> </tr> <tr> <td>HALF</td> <td>1</td> <td>1</td> <td>2</td> <td>2</td> <td>3</td> <td>4</td> <td>4</td> <td>5</td> <td>5</td> <td>9</td> </tr> </tbody> </table>		VALUE	5mph		10mph		15mph		20mph		25mph			M16A4	M4	M16A4	M4	M16A4	M4	M16A4	M4	M16A4	M4	FULL	2	3	5	5	7	8	9	10	11	19	HALF	1	1	2	2	3	4	4	5	5	9		
VALUE	5mph		10mph		15mph		20mph		25mph																																								
	M16A4	M4	M16A4	M4	M16A4	M4	M16A4	M4	M16A4	M4																																							
FULL	2	3	5	5	7	8	9	10	11	19																																							
HALF	1	1	2	2	3	4	4	5	5	9																																							
<b>WEATHER DATA</b>												<b>REMARKS</b>																																					
LIGHT <input type="checkbox"/> OVERCAST <input type="checkbox"/> PARTLY CLOUDY <input type="checkbox"/> CLEAR <input type="checkbox"/> DRY <input type="checkbox"/> LT RAIN <input type="checkbox"/> MIST <input type="checkbox"/> HVY RAIN												<b>AFTER FIRING</b>																																					
																																																	

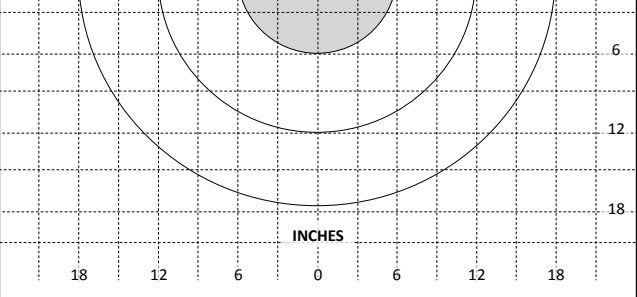
200 YARD RAPID-FIRE		BEFORE FIRING										DAY TEN																																					
ZERO		+ WIND =										HOLD																																					
		HOLDS IN INCHES 																																															
		<table border="1" style="font-size: small;"> <thead> <tr> <th>VALUE</th> <th colspan="2">5mph</th> <th colspan="2">10mph</th> <th colspan="2">15mph</th> <th colspan="2">20mph</th> <th colspan="2">25mph</th> </tr> <tr> <td></td> <th>M16A4</th> <th>M4</th> <th>M16A4</th> <th>M4</th> <th>M16A4</th> <th>M4</th> <th>M16A4</th> <th>M4</th> <th>M16A4</th> <th>M4</th> </tr> </thead> <tbody> <tr> <td>FULL</td> <td>2</td> <td>3</td> <td>5</td> <td>5</td> <td>7</td> <td>8</td> <td>9</td> <td>10</td> <td>11</td> <td>19</td> </tr> <tr> <td>HALF</td> <td>1</td> <td>1</td> <td>2</td> <td>2</td> <td>3</td> <td>4</td> <td>4</td> <td>5</td> <td>5</td> <td>9</td> </tr> </tbody> </table>		VALUE	5mph		10mph		15mph		20mph		25mph			M16A4	M4	M16A4	M4	M16A4	M4	M16A4	M4	M16A4	M4	FULL	2	3	5	5	7	8	9	10	11	19	HALF	1	1	2	2	3	4	4	5	5	9		
VALUE	5mph		10mph		15mph		20mph		25mph																																								
	M16A4	M4	M16A4	M4	M16A4	M4	M16A4	M4	M16A4	M4																																							
FULL	2	3	5	5	7	8	9	10	11	19																																							
HALF	1	1	2	2	3	4	4	5	5	9																																							
<b>WEATHER DATA</b>												<b>REMARKS</b>																																					
LIGHT <input type="checkbox"/> OVERCAST <input type="checkbox"/> PARTLY CLOUDY <input type="checkbox"/> CLEAR <input type="checkbox"/> DRY <input type="checkbox"/> LT RAIN <input type="checkbox"/> MIST <input type="checkbox"/> HVY RAIN												<b>AFTER FIRING</b>																																					
																																																	



**300 YARD RAPID-FIRE** **BEFORE FIRING** **DAY TEN**

**ZERO** **+ WIND =** **HOLD**

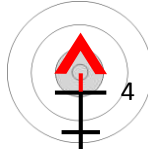
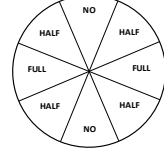
HOLDS IN INCHES

VALUE	5mph		10mph		15mph		20mph		25mph	
	M16A4	M4	M16A4	M4	M16A4	M4	M16A4	M4	M16A4	M4
FULL	5	6	11	13	16	18	22	25	27	32
HALF	2	3	5	6	8	9	11	12	13	16



**WEATHER DATA**

LIGHT

OVERCAST

PARTLY CLOUDY

CLEAR

DRY  LT RAIN

MIST  HVY RAIN

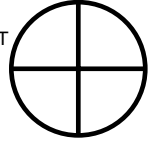
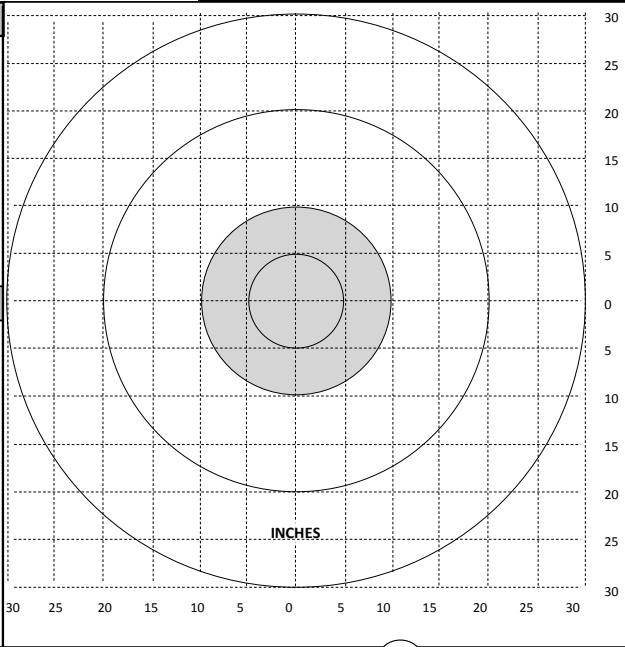
**REMARKS**

**300 YARD RAPID-FIRE** **BEFORE FIRING** **DAY TEN**

**ZERO** **+ WIND =** **HOLD**

HOLDS IN INCHES

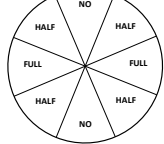
VALUE	5mph		10mph		15mph		20mph		25mph	
	M16A4	M4	M16A4	M4	M16A4	M4	M16A4	M4	M16A4	M4
FULL	5	6	11	13	16	18	22	25	27	32
HALF	2	3	5	6	8	9	11	12	13	16



**WEATHER DATA**

LIGHT

OVERCAST

PARTLY CLOUDY





CLEAR

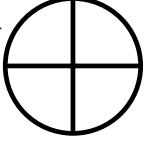
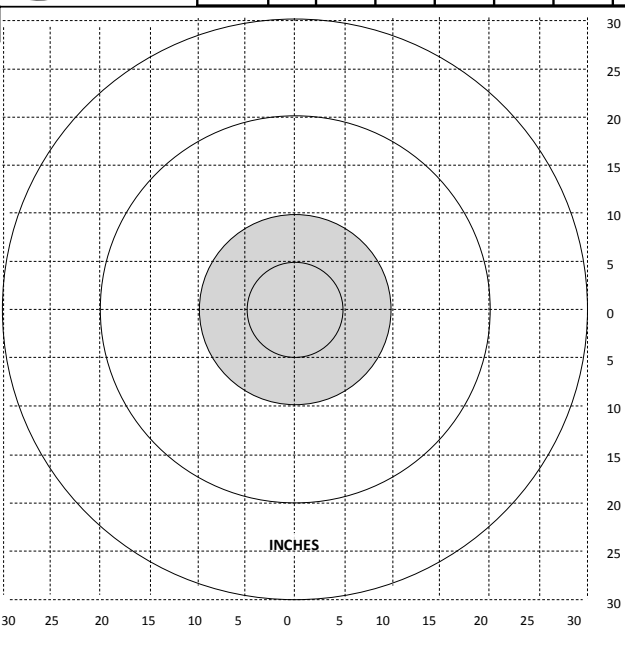

DRY  LT RAIN

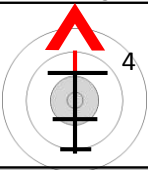
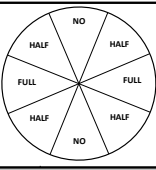
MIST  HVY RAIN

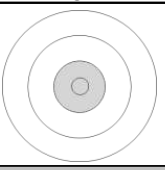
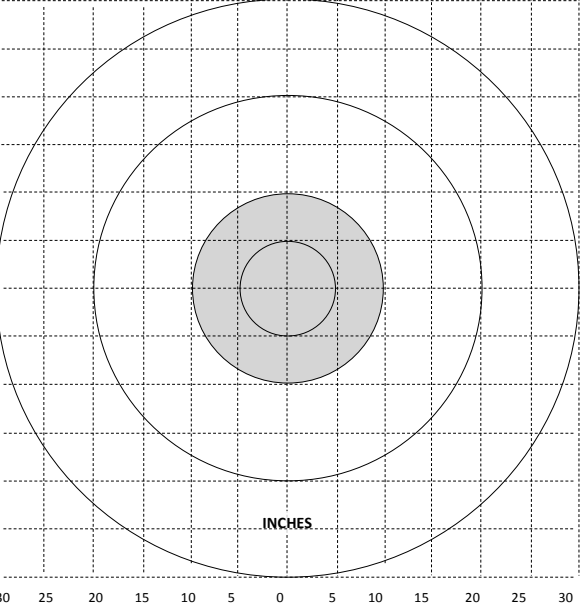
**REMARKS**

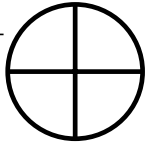
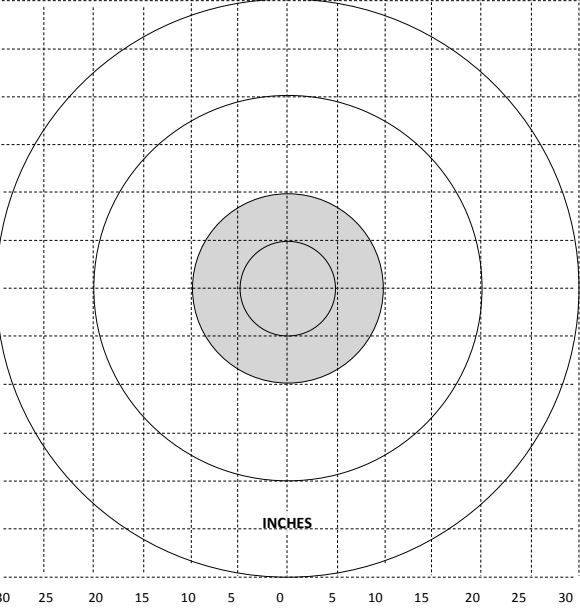
500 YARD SLOW-FIRE				BEFORE FIRING										DAY TEN																												
ZERO				+ WIND =										HOLD																												
				HOLDS IN INCHES 																																						
				<table border="1" style="font-size: small;"> <tr> <th>VALUE</th> <th colspan="2">5mph</th> <th colspan="2">10mph</th> <th colspan="2">15mph</th> <th colspan="2">20mph</th> <th colspan="2">25mph</th> </tr> <tr> <td>FULL</td> <td>M16A4</td> <td>M4</td> <td>M16A4</td> <td>M4</td> <td>M16A4</td> <td>M4</td> <td>M16A4</td> <td>M4</td> <td>M16A4</td> <td>M4</td> </tr> <tr> <td>HALF</td> <td>8</td> <td>10</td> <td>17</td> <td>20</td> <td>26</td> <td>30</td> <td>34</td> <td>40</td> <td>43</td> <td>50</td> </tr> </table>		VALUE	5mph		10mph		15mph		20mph		25mph		FULL	M16A4	M4	M16A4	M4	M16A4	M4	M16A4	M4	M16A4	M4	HALF	8	10	17	20	26	30	34	40	43	50				
VALUE	5mph		10mph		15mph		20mph		25mph																																	
FULL	M16A4	M4	M16A4	M4	M16A4	M4	M16A4	M4	M16A4	M4																																
HALF	8	10	17	20	26	30	34	40	43	50																																
WEATHER DATA														<b>AFTER FIRING</b> 																												
LIGHT <input type="checkbox"/> OVERCAST <input type="checkbox"/> PARTLY CLOUDY <input type="checkbox"/> CLEAR														PRECIP <input type="checkbox"/> DRY <input type="checkbox"/> LT RAIN <input type="checkbox"/> MIST <input type="checkbox"/> HVY RAIN																												
DURING FIRING														<b>REMARKS</b>  																												
1	2	3	4											5	6	7	8	9	10	11	12	13	14	15	16	17	18	19	20													

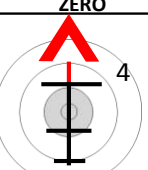
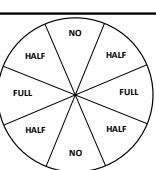
500 YARD SLOW-FIRE				BEFORE FIRING										DAY TEN																												
ZERO				+ WIND =										HOLD																												
				HOLDS IN INCHES 																																						
				<table border="1" style="font-size: small;"> <tr> <th>VALUE</th> <th colspan="2">5mph</th> <th colspan="2">10mph</th> <th colspan="2">15mph</th> <th colspan="2">20mph</th> <th colspan="2">25mph</th> </tr> <tr> <td>FULL</td> <td>M16A4</td> <td>M4</td> <td>M16A4</td> <td>M4</td> <td>M16A4</td> <td>M4</td> <td>M16A4</td> <td>M4</td> <td>M16A4</td> <td>M4</td> </tr> <tr> <td>HALF</td> <td>8</td> <td>10</td> <td>17</td> <td>20</td> <td>26</td> <td>30</td> <td>34</td> <td>40</td> <td>43</td> <td>50</td> </tr> </table>		VALUE	5mph		10mph		15mph		20mph		25mph		FULL	M16A4	M4	M16A4	M4	M16A4	M4	M16A4	M4	M16A4	M4	HALF	8	10	17	20	26	30	34	40	43	50				
VALUE	5mph		10mph		15mph		20mph		25mph																																	
FULL	M16A4	M4	M16A4	M4	M16A4	M4	M16A4	M4	M16A4	M4																																
HALF	8	10	17	20	26	30	34	40	43	50																																
WEATHER DATA														<b>AFTER FIRING</b> 																												
LIGHT <input type="checkbox"/> OVERCAST <input type="checkbox"/> PARTLY CLOUDY <input type="checkbox"/> CLEAR														PRECIP <input type="checkbox"/> DRY <input type="checkbox"/> LT RAIN <input type="checkbox"/> MIST <input type="checkbox"/> HVY RAIN																												
DURING FIRING														<b>REMARKS</b>  																												
1	2	3	4											5	6	7	8	9	10	11	12	13	14	15	16	17	18	19	20													

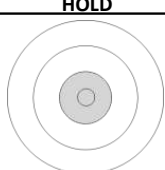
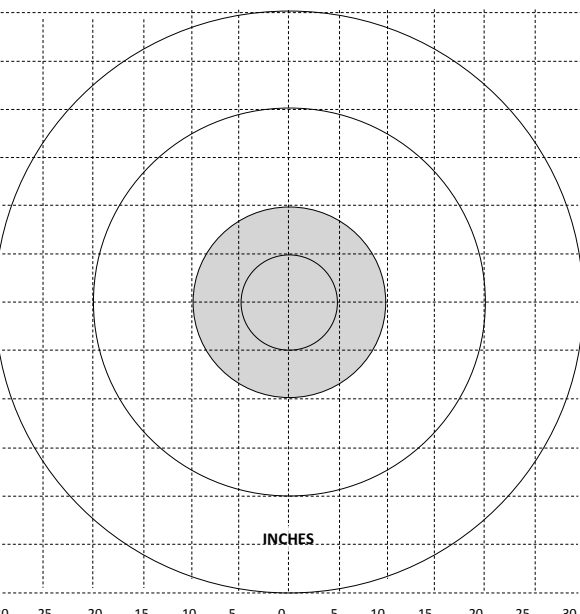
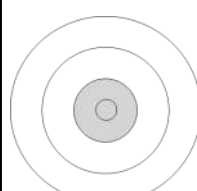
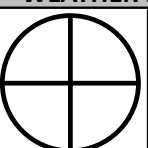
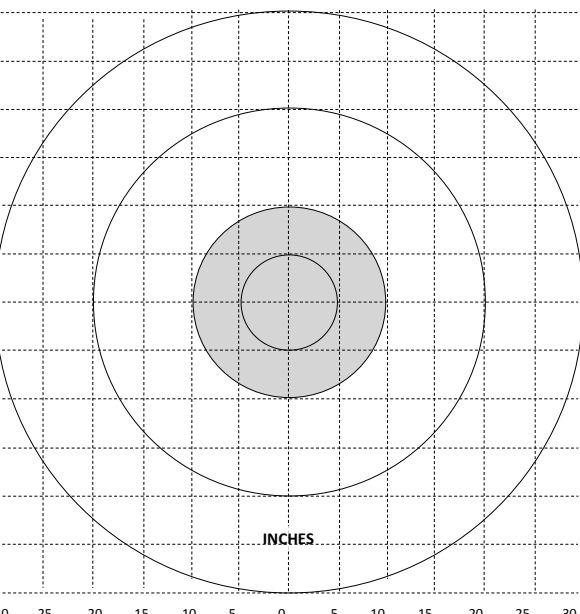
*"The deadliest weapon in the world is a Marine and his rifle".*

- General John "Black Jack" Pershing, Commander of the American Expeditionary Force in World War I



*"Every Marine is, first and foremost, a rifleman. All other conditions are secondary".*

- General Alfred M. Gray, 29th Commandant of the Marine Corps

*"The deadliest weapon in the world is a Marine and his rifle".*

- General John "Black Jack" Pershing, Commander of the American Expeditionary Force in World War I



*"Every Marine is, first and foremost, a rifleman. All other conditions are secondary".*

- General Alfred M. Gray, 29th Commandant of the Marine Corps