

---

# CLOSE AIR SUPPORT

---



---

**U.S. Marine Corps**

DEPARTMENT OF THE NAVY  
Headquarters United States Marine Corps  
Washington, DC 20380-1775

30 July 1998

FOREWORD

Close air support (CAS) is a Marine Corps innovation. Since the first dive bombing attempts in World War I and subsequent operations in Haiti, the Dominican Republic, and Nicaragua in the 1920s, Marines have realized the value of closely integrating aviation with ground combat efforts. World War II and the Korean war galvanized the importance of CAS. During those conflicts, the fundamental tactics, techniques, and procedures (TTP) for conducting CAS today were forged in places such as Guadalcanal and the Pusan Perimeter. Today, CAS continues to be Marine aviation's unique contribution to the combat power available to a Marine air-ground task force (MAGTF) commander.

Marine Corps Warfighting Publication (MCWP) 3-23.1, *Close Air Support*, addresses basic CAS doctrine and TTP. MCWP 3-23.1 complements and expands on the information in MCWP 3-23, *Offensive Air Support*, by focusing on the details of CAS employment and the role CAS plays in integrated MAGTF, joint, and multinational operations. Designated for MAGTF commanders, naval expeditionary force commanders, joint force commanders, and their staffs, MCWP 3-23.1 highlights CAS:

- Fundamentals
- Command, control, and communications
- Planning considerations
- Execution using fixed- and rotary-wing aircraft.

MCWP 3-23.1 provides the requisite information needed by commanders and staffs to understand and evaluate the capabilities of various CAS employment options. Additionally, MCWP 3-23.1 offers standard procedures and terminology by which ground force personnel and pilots of fixed- and rotary-wing aircraft can deliver aircraft ordnance in close proximity to friendly forces.

This publication supersedes Fleet Marine Force Manual (FMFM) 5-41, *Close Air Support and Close-in Fire Support*.

Recommendations for improving this publication are invited from commands as well as directly from individuals.

Reviewed and approved this date.

BY DIRECTION OF THE COMMANDANT OF THE MARINE CORPS

J. E. RHODES  
Lieutenant General, U.S. Marine Corps  
Commanding General  
Marine Corps Combat Development Command

DISTRIBUTION: 143 000055 00

# CLOSE AIR SUPPORT

## Table Of Contents

	<b>Page</b>
<b>Chapter 1. Fundamentals</b>	
Introduction	1-1
Fratricide	1-3
Battlefield Utility	1-4
Close Air Support Integration	1-5
Close Air Support Employment	1-5
Threat Levels	1-7
Conditions for Effective Close Air Support	1-8
<b>Chapter 2. Command, Control, and Communications</b>	
Amphibious Tactical Air Control System	2-1
Navy Tactical Air Control System	2-3
Marine Air Command and Control System	2-4
Communications	2-10
Close Air Support Command and Control for Joint Force Operations	2-15

## **Chapter 3. Planning**

### **Section I. Basic Considerations**

Close Air Support Employment Planning	3-1
Close Air Support Mission Planning	3-6
Close Air Support Navigation Planning	3-11
Close Air Support Logistic Planning	3-13

### **Section II. Control and Coordination Measures**

Airspace Control Measures	3-16
Fire Support Coordination Measures	3-26
Integrating Close Air Support with Other Fires	3-30
Coordinated Operations	3-42

### **Section III. Requesting and Tasking**

MAGTF Commander's Guidance	3-43
Close Air Support Requests	3-43
Close Air Support Requests Afloat	3-48
Joint Close Air Support Request Procedures	3-49
Request Format	3-51
Mission Data	3-51

### **Section IV. Night/Adverse Weather Close Air Support Planning**

Basic Considerations	3-52
Aircraft Munitions and Equipment Selection	3-53
Visual Employment	3-55
System-Aided Employment	3-56

Night Vision Device Employment	3-57
Target Identifiers	3-60

## **Chapter 4. Execution**

### **Section I. Basic Considerations**

Synchronized Timing	4-1
Security	4-2
Check-In	4-2
Close Air Support Briefing Form	4-2
Risk-Estimate Distance	4-7
Target Marking	4-8
Final Attack Control	4-13
Abort Procedures	4-18
Battle Damage Assessment	4-19

### **Section II. Night/Limited-Visibility Close Air Support**

Visual Employment	4-22
System-Aided Employment	4-22
Night Vision Goggle Employment	4-23

### **Section III. Close Air Support Execution with Laser-Guided Systems**

Basic Requirements	4-25
Laser-Guided Weapons	4-26
Laser Target Designators	4-27

Laser Spot Trackers	4-28
Laser Procedures	4-28

#### **Section IV. Fixed-Wing Execution**

Launch and Departure Procedures	4-34
En Route Tactics (Before the Contact Point)	4-34
Ingress Tactics (Contact Point to Initial Point)	4-38
Attack Phase (Initial Point to Target)	4-41
Fixed-Wing Laser-Guided System Employment	4-48
Egress	4-51

#### **Section V. Rotary-Wing Execution**

Launch and Departure Procedures (Takeoff to Rendezvous Point)	4-53
En Route Tactics (Rendezvous Point to Holding Area)	4-53
Ingress Tactics (Holding Area to Battle Position)	4-55
Attack Phase (Within the Battle Point)	4-58
Disengagement and Egress	4-61
Rotary-Wing Laser-Guided Systems Employment	4-62

#### **Section VI. Return-to-Force**

Procedures	4-67
Debriefing	4-68

## Appendices

A	Close Air Support Aircrew Mission Planning Guide	A-1
B	Planning Considerations for Close Air Support Using Night Vision Goggles and Infrared Pointers	B-1
C	Aircraft Weapons and Capabilities Guide	C-1
D	Joint Tactical Airstrike Request	D-1
E	Communications Equipment	E-1
F	Risk-Estimate Distances	F-1
G	NATO Close Air Support Formats	G-1
H	AC-130 Close Air Support Employment	H-1
I	Glossary	I-1
J	References and Related Publications	J-1

(reverse blank)



## Chapter 1

# Fundamentals

### INTRODUCTION

CAS is an “air action by fixed- and rotary-wing aircraft against hostile targets which are in close proximity to friendly forces and which require detailed integration of each air mission with the fire and movement of those forces.” (Joint Publication (Joint Pub) 1-02, *DOD Dictionary of Military and Associated Terms*)

CAS is an offensive air support (OAS) mission that is planned and executed to deliver firepower against selected enemy capabilities at a designated place and time. By using the speed and mobility of aircraft, CAS provides the commander with the means to strike the enemy swiftly and unexpectedly. Applying the fundamentals of combined arms, the commander integrates CAS with other forms of fire support and the fire and movement of ground forces. In so doing, the commander takes advantage of fleeting battlefield opportunities and achieves combat objectives. CAS is a mission conducted at the tactical level that may affect operational-level objectives.

CAS is conducted when and where friendly combat forces are in close proximity to enemy forces. The word “close” does not imply a specific distance; rather, it is situational. The requirement for detailed integration based on proximity, fires, or movement is the determining factor. CAS provides firepower to neutralize, destroy, or delay enemy forces in offensive and defensive operations.

At times, CAS is the best firepower delivery means available to rapidly mass a lethal capability, exploit tactical opportunities, or save

friendly lives. Available aircraft that are capable of performing CAS are fully integrated into ground operations, thereby giving the commander flexibility in force employment. The effectiveness of CAS is proportional to the degree to which it is integrated into the planning and conduct of MAGTF operations. The supported unit commander influences the use of CAS by requesting and approving all CAS missions within his area of operations.

The MAGTF commander uses CAS to concentrate firepower on the enemy. CAS provides fire support with the speed and violence that is essential in maneuver warfare. The MAGTF commander uses the following criteria to determine CAS employment:

- The MAGTF's mission and concept of operations
- The MAGTF's ability to counter enemy air defenses
- The availability of, and compatibility with, other supporting arms.

Proper and timely communication and control are necessary if CAS is to be successful. To deliver effective CAS, an aircrew must:

- Be responsive
- Remain flexible
- Be familiar with the supported unit's scheme of maneuver and understand the MAGTF commander's intent
- Acquire the correct target
- Place the appropriate type of ordnance accurately on the target.

Although the concept is simple, CAS requires detailed planning, coordination, and training for effective and safe execution.

## FRATRICIDE

Fratricide, or casualties to friendly forces caused by friendly fire, is an undesirable and avoidable circumstance in warfare. All of the TTP outlined throughout this publication are designed to avoid fratricide while maximizing the effectiveness of CAS.

- **Causes.** Although it is occasionally the result of a malfunctioning weapon, fratricide is often the result of uncertainty on the battlefield. Causes include misidentification of targets, target location errors, target locations incorrectly transmitted or received, and loss of situational awareness by either terminal controllers, CAS aircrews, or fire support coordinators. Combat identification (CID) is critical to ensure that effective CAS is delivered while minimizing the potential for fratricide. Commanders, planners, and mission executors must be conversant in standing operating procedures (SOPs) regarding CID. All participants in the CAS process must realize that they could possibly contribute to unintentional or inadvertent friendly fire incidents and therefore must make every effort to prevent such occurrences.
- **Responsibility.** All participants in the CAS employment process—maneuver commanders, commanders providing fire support, fire support coordinators, targeters, terminal controllers, and aircrews—are responsible for the effective and safe execution of CAS. Each participant must make every effort to ensure that friendly units and enemy forces are correctly identified before the release of ordnance. Ultimately, the terminal

controller issuing the “cleared hot” clearance has the responsibility of ensuring that fratricide will not occur when employing CAS.

- **Training.** Commanders and units must constantly emphasize training that routinely exercises CAS TTP. Continuous, realistic training creates a better understanding of battlefield conditions and the situations in which CAS may be employed. Successful CAS training will result in safe and effective CAS employment and provide for synergistic fire support during all MAGTF operations.

## **BATTLEFIELD UTILITY**

Ground force commanders request CAS to augment organic supporting fires. CAS is used to attack the enemy in a majority of weather conditions, day or night. When CAS is properly employed, commanders can focus its firepower at the decisive time and place to achieve tactical objectives. Advances in TTP and equipment have improved the ability of aircraft to provide close support. By using CAS, commanders can take full advantage of battlefield opportunities. The three-dimensional mobility of aircraft provides commanders with the means to strike the enemy swiftly and unexpectedly. The speed, range, and maneuverability of aircraft allow the attack of targets that other supporting arms may not be able to effectively engage because of limiting factors, such as type of target, range, the terrain, or the friendly ground scheme of maneuver.

## **Planning Criteria**

The commanders consider the following criteria in planning for CAS:

- Mission and concept of operations
- Enemy air defenses and the force's ability to counter them
- Integration with other supporting arms
- Types of CAS assets available
- Availability of the correct ordnance for the target.

### **CLOSE AIR SUPPORT INTEGRATION**

CAS is integrated with other available supporting fires to support maneuver forces. Whether conducting offensive or defensive operations, commanders plan for CAS at key points throughout the depth of the battlefield. The priority for the assignment of CAS is established by the MAGTF commander and supports his intent and concept of operation. Commensurate with other mission requirements, the aviation combat element (ACE) commander postures aviation assets to optimize support to requesting units.

### **CLOSE AIR SUPPORT EMPLOYMENT**

The organizational structure, missions, and characteristics of CAS-capable aircraft determine how CAS is employed. The integration of CAS-capable aircraft allows ground force commanders to take advantage of the distinctly different, but complementary,

capabilities of each platform to support the fire and maneuver of their units. Although fixed- and rotary-wing aircraft can both provide CAS, employment considerations differ. Some planning and employment methods for CAS with fixed-wing aircraft are not the same as for rotary-wing aircraft.

Although attack helicopters and fixed-wing aircraft capabilities are complementary, neither capability can fully replace the air support provided by the other. The range, speed, and ordnance load of fixed-wing aircraft and the helicopter's excellent responsiveness and ability to operate in diverse conditions represent distinct advantages that are peculiar to each.

To facilitate the integration necessary for effective CAS, aircraft are normally based as close as possible to supported units. CAS aircraft can be provided from main airbases, forward operating bases (FOBs), amphibious ships, or aircraft carriers. This versatility in employment locations is vital when conducting ship-to-objective maneuver (STOM) during operational maneuver from the sea (OMFSTS). The ability to operate from areas close to, or over the horizon from, friendly forces offers ground forces greater CAS responsiveness, while providing aviation forces the flexibility to choose the best means to employ CAS assets.

Fixed-wing aircraft are typically tasked and employed to conduct CAS in terms of aircraft sorties. A sortie is defined as "an operational flight by one aircraft." (Joint Pub 1-02) Fixed-wing CAS sorties are normally flown in sections (two aircraft) or divisions (four aircraft).

Rotary-wing aircraft providing CAS are typically tasked and employed in sections, divisions, or flights (two or more divisions). Both fixed- and rotary-wing aircraft are normally assigned as part of the ACE of a MAGTF.

## THREAT LEVELS

Threat levels (low, medium, and high) determine CAS feasibility. These are general levels, and at times no clear dividing line may exist between them. Threat levels exist between no air threat capability on the low end to a highly developed and integrated air defense system on the high end. Determination of the threat level is based on:

- The type, quantity, and quality of enemy individual weapons and weapons systems
- Enemy command, control, communications, computers, and intelligence (C4I) systems used to integrate weapons
- Enemy training status.

Threat-level determination is based heavily on enemy capabilities, but friendly capabilities are also weighed in meeting the threat and environmental conditions. Air defense systems that present a low or medium threat level for one type of aircraft may present a high threat level for another type of aircraft. A medium threat level during daylight hours may be a low threat level at night. Current intelligence is used to determine the threat level. Threat-level determination aids aircrews when preparing tactics for a particular situation and environment.

Threat-level identification should be considered when determining air support mission feasibility. See MCWP 3-23 for more information.

## CONDITIONS FOR EFFECTIVE CLOSE AIR SUPPORT

For CAS to be delivered effectively, some basic conditions that optimize CAS employment must be considered. These conditions include those discussed in the following paragraphs.

### **Air Superiority**

Air superiority permits CAS operations to function more freely and denies the same advantage to the enemy. Air superiority may range from local or temporary control of the air to control over the entire theater. Air superiority is “that degree of dominance in the air battle of one force over another that permits the conduct of operations by the former and its related land, sea, and air forces at a given time and place without prohibitive interference by the opposing force.” (Joint Pub 1-02) This will involve negating enemy airborne and ground systems, including air-to-air, air-to-surface, surface-to-air, and electronic warfare (EW) systems to a level at which they are incapable of having an adverse effect on friendly force operations.

### **Suppression of Enemy Air Defenses**

Suppression of enemy air defenses (SEAD) may be required for CAS aircraft to operate within areas defended by enemy air defense systems. Available methods to suppress enemy air defense threats include destructive and disruptive means. See MCWP 3-22.2, *Suppression of Enemy Air Defenses*, and Joint Pub 3-01.4, *Joint Tactics, Techniques, and Procedures (JTTP) for Joint Suppression of Enemy Air Defenses (J-SEAD)*, for more information.



## **Target Marking**

The requesting commander can improve CAS effectiveness by providing timely and accurate target marks. Target marking aids CAS aircrews in building situational awareness and in locating and attacking the proper target. See Chapter 4 for further details.

## **Favorable Weather**

Unrestricted horizontal visibility improves CAS aircrew effectiveness regardless of aircraft type. Before CAS missions are executed, minimum weather conditions are considered. The ACE commander determines the worst weather conditions in which CAS missions can be conducted based on regulations, aircraft and equipment limitations, and aircrew experience. Weather conditions worse than those considered to be the minimum will significantly degrade the ability to perform CAS because the majority of CAS aircraft do not have a true all-weather capability.

## **Prompt Response**

To be effective, CAS must be responsive. Streamlined request and control procedures improve responsiveness. Prompt response allows a commander to exploit planned objectives and to take advantage of unanticipated battlefield opportunities. Techniques for improving response time include:

- Using FOBs to decrease the distance to the area of operations
- Placing aircraft on ground or airborne alert status

- Delegating launch and divert authority to subordinate units.

### **Aircrew and Terminal Controller Skill**

CAS execution is complex. Aircrew and terminal controller skills have a direct influence on mission success. Maintaining a high degree of skill requires that aircrews and terminal controllers practice frequently. Realistic training that includes all maneuver elements is essential.

### **Weaponneering**

To achieve the desired level of destruction, neutralization, or suppression of enemy CAS targets, the weapons load, arming settings, and fusing settings must be tailored for the desired results. Cluster and general-purpose munitions are very effective against troops and stationary vehicles. However, hardened, mobile, or pinpoint targets may require specialized weapons, such as laser-guided, electro-optical, or infrared (IR) munitions, or aircraft with special equipment or capabilities. The requesting commander should solicit the type and quantity of ordnance that is appropriate to his needs and be informed of the ordnance load that each supporting CAS aircraft is carrying.

### **Communications and Information Systems**

CAS execution requires dependable and interoperable communications. Unhindered voice or data communications between aircrews, air control agencies, terminal controllers, supported commanders, and fire support agencies greatly increase the ease by which CAS is requested and controlled. Additionally, information flow will come from the battlespace in the form of in-flight reports and mission

reports (MISREPs). Information systems that can relay timely and perishable information, such as target activity after attack and additional targets, will facilitate real-time CAS decisionmaking as well as future CAS planning.

### **Command and Control**

CAS requires integrated, flexible command and control (C2). C2 that facilitates an understanding of the mission and the initiative to adapt to changing battlefield situations is the foundation for creating conditions favorable for CAS employment. Basic requirements for CAS C2 are the ability to process CAS requests, assign assets, communicate taskings, deconflict fires and routing, coordinate support, establish airspace control measures, and update or warn CAS aircraft of enemy threats.

(reverse blank)

## Chapter 2

# Command, Control, and Communications

CAS requires a C2 structure that can coordinate requirements, process requests, and control execution. The amphibious tactical air control system (ATACS) is organized and equipped to plan, direct, and control all air operations within an assigned area. The ATACS can also coordinate air operations with the other components of a joint force.

### **AMPHIBIOUS TACTICAL AIR CONTROL SYSTEM**

The subordinate systems of the ATACS are the Navy tactical air control system (NTACS) and the Marine air command and control system (MACCS). Through the control agencies and facilities of the NTACS and MACCS, commanders exercise the necessary C2 of available aviation assets. Figure 2-1 illustrates the necessary connectivity between the key elements, fire support centers, and air C2 agencies of the ATACS. See Navy warfare publication (NWP) 3-09.11, *Supporting Arms in Amphibious Operations*, and MCWP 3-31.1, *Fire Support in Amphibious Operations*, for a detailed discussion of the NTACS. See MCWP 3-25.3, *Marine Air Command and Control System Handbook*, for a detailed discussion of the MACCS. See Joint Pubs 3-02, *Joint Doctrine for Amphibious Operations*; 3-02.1, *Joint Doctrine for Landing Force Operations*; and 3-52, *Doctrine for Joint Airspace Control in the Combat Zone*, for further information concerning air C2 in amphibious operations.

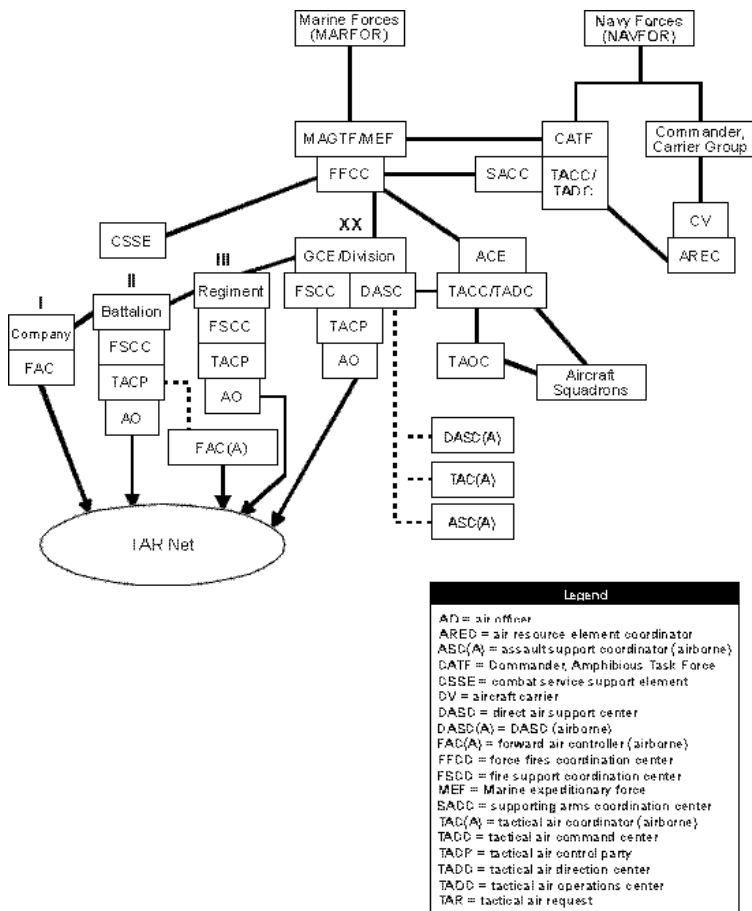

Figure 2-1. Navy/Marine Corps Close Air Support Connectivity.

## NAVY TACTICAL AIR CONTROL SYSTEM

The NTACS is the principal air control system afloat. The senior Navy air control agency is the Navy tactical air control center (TACC). When required, a subordinate air control agency, the tactical air direction center (TADC), may be established.

- **Navy TACC/TADC.** The Navy TACC controls all air operations within the amphibious objective area (AOA). The TACC/TADC is responsible for planning and conducting CAS. Typically, the Navy TACC is onboard the amphibious task force (ATF) flagship. If the joint force commander (JFC) designates a seabased joint force air component commander (JFACC), the Navy TACC may host the joint air operations center (JAOC).

If two or more ATACS command-level agencies are operating within an AOA, one agency functions as the TACC and the other(s) functions as the TADC(s). When established, the TADCs are under operational control (OPCON) of the TACC, the TADC exercises only those functions delegated by the TACC. When the Marine TACC is established, the Navy TACC is redesignated a TADC, and other centers become subordinate. The Navy TADC functions in a standby status, prepared to reassume its role as the TACC should the situation dictate.

The Navy TACC has two sections that control and integrate CAS: the air traffic control section (ATCS) and the air support control section (ASCS).

- **ATCS.** The ATCS provides initial safe passage, radar control, and surveillance for CAS aircraft in the AOA. The ATCS can also provide early detection, identification, and warning of enemy aircraft.
- **ASCS.** The ASCS is the section of the TACC designed to coordinate and control overall CAS employment. The primary task of the ASCS is to provide fast reaction to CAS requests from the landing force. The ASCS coordinates with the supporting arms coordination center (SACC) to integrate CAS and other supporting arms; provides tactical air direction of assigned aircraft; provides aircrews with current and complete friendly intelligence, enemy intelligence, and target briefings; passes CAS control to the terminal controller; executes the CAS portion of the air tasking order (ATO); and acts as the action agency for immediate CAS requests.
- **SACC.** Although the SACC is not part of the ATACS, it is integral to amphibious assault supporting arms C2. The SACC processes joint tactical airstrike requests (JTARs) and determines which supporting arm is best suited to engage targets. The SACC maintains radio contact on tactical air request (TAR) nets with tactical air control parties (TACPs) to coordinate CAS requests.

## **MARINE AIR COMMAND AND CONTROL SYSTEM**

The MACCS provides the MAGTF with the means to integrate, coordinate, and control all air operations within its area of operations and with joint/combined forces. The principal agencies of the MACCS concerned with CAS are the Marine TACC/TADC, the



tactical air operations center (TAOC), and the direct air support center (DASC). (See figure 2-1.)

### **Marine Tactical Air Command Center/ Tactical Air Direction Center**

The Marine TACC is the senior MACCS agency and is the focal point for aviation C2. It is the operational command post for the ACE commander. The Marine TACC can host the JAOC when the Marine component provides the JFACC.

The Marine TADC is the senior MACCS agency until the MAGTF assumes control of all air operations. Once the MAGTF assumes control, the TADC is designated the Marine TACC.

### **Tactical Air Operations Center**

The TAOC is subordinate to the Marine TACC. The TAOC provides safe passage, radar control, and surveillance for CAS aircraft en route to and from target areas. See MCWP 3-25.7, *Tactical Air Operations Center Handbook*, for a detailed discussion of the TAOC.

### **Direct Air Support Center**

Typically, this center is the first principal MACCS agency established ashore in an area of operations and is subordinate to the Marine TACC. The DASC can serve as the alternate TACC for a limited period when the TACC echelons forward or becomes a casualty. The DASC coordinates CAS and is normally collocated with the ground combat element's (GCE's) senior fire support coordination center (FSCC). When there are multiple GCEs, the DASC

may be collocated with the MAGTF's force fires coordination center (FFCC). An airborne DASC can be operated from the KC-130 aircraft. The DASC (airborne) (DASC(A)) normally serves as an airborne extension of the DASC, but can be employed as an independent control agency. See MCWP 3-25.5, *Direct Air Support Center Handbook*, for a detailed discussion of the DASC.

- **Tasks.** The DASC processes immediate direct air support requests and coordinates the execution of preplanned and immediate direct air support missions, including CAS. The DASC also coordinates with the senior GCE FSCC to integrate CAS with supporting arms.
- **Supporting Arms Integration.** The link between the DASC and the senior FSCC is critical for the coordination and integration of CAS missions with other supporting arms. The DASC receives current ground and air intelligence information primarily from aircrews operating within the battlespace. Aircrews can pass visual reconnaissance reports that are essential to timely battlefield targeting directly to the DASC, which then passes this information to the Marine TACC/TADC and the senior FSCC. The FSCC uses these visual reconnaissance reports in the assessment phase of the targeting process.

## MACCS Terminal Control Agencies

CAS terminal control agencies control the final delivery of ordnance. Terminal control agencies require continuous communications and the ability to track CAS aircraft by visual or electronic means. Some terminal control agencies, such as TACPs, are not organic to the ACE. The MACCS integrates terminal controllers into the C2 system through communications and standard procedures.

- **TACP.** The TACP, which plays an important role in the air C2 system, is responsible for reporting employment and coordination of CAS to the supported ground commander. TACP provides a means for the ground commander to access the MACCS to fulfill his direct air support requirements. TACPs exist at the MAGTF level through the battalion level and are primarily used to integrate and coordinate air support in the fire support process. At the battalion level, the TACP is also used to provide terminal control for CAS aircraft.
- **Organization.** The battalion TACP consists of 3 aviators and 12 radio operators. The senior officer is the air officer (AO), who acts in a dual capacity as special staff officer to the battalion commander for all aviation matters and as the officer in charge of the TACP. Each of the other two aviation officers is a forward air controller (FAC) and the leader of a forward air control party. Each forward air control party has four communicators. Regimental, division, and MAGTF TACPs do not have FACs.
- **Tasks** The TACP participates in fire support coordination. The AO advises the ground unit commander on CAS employment and works in the FSCC as the battalion's air representative. The forward air control parties prepare the majority of the preplanned and immediate requests for CAS and provide the battalion with its CAS terminal control capability.
- **FAC.** The FAC provides terminal control for CAS aircraft and maintains radio communications with assigned CAS aircrews from a forward ground position. FAC terminal control aids in target identification and greatly reduces the potential for fratricide. The duties of the FAC include:
  - Knowing the enemy situation, selected targets, and location of friendly units

- Knowing the supported unit's plans, position, and needs
  - Locating targets of opportunity
  - Advising the supported company commander on proper air employment
  - Requesting CAS
  - Controlling CAS
  - Performing battle damage assessment (BDA).
- **Airborne Controllers and Coordinators.** The airborne MACCS agency that provides airborne terminal control of CAS aircraft is the FAC (airborne) (FAC(A)). The tactical air coordinator (airborne) (TAC(A)) provides coordination for OAS missions. The assault support coordinator (airborne) (ASC(A)) provides coordination of CAS for assault support missions.
  - **FAC(A).** The FAC(A) is an airborne extension of the TACP. The FAC(A) can serve as another FAC for the TACP or augment and extend the acquisition range of a forward air control party. The FAC(A)'s mission is different from the TAC(A)'s mission. The FAC(A) provides terminal control of CAS aircraft, while a TAC(A) aids in the coordination of available supporting arms. FAC(A) and TAC(A) missions should not be conducted simultaneously by the same aircrew. FAC(A) duties include detecting and destroying enemy targets, coordinating or conducting target marking, providing terminal control of CAS missions, conducting air reconnaissance, providing artillery and naval gunfire air spotting, providing radio relay for the TACP and FAC, and performing BDA.

- **TAC(A).** The TAC(A) is an officer operating from an aircraft who coordinates CAS and other supporting arms with ground combat operations while providing airspace coordination. The TAC(A) is an airborne extension of the DASC or Marine TACC/TADC. The DASC or Marine TACC/TADC identifies specific TAC(A) authority. The TAC(A) coordinates with TACPs, FSCCs, subordinate FAC(A)s, artillery units, and naval surface fire support (NSFS) ships. TAC(A) duties include coordinating CAS attack briefs and timing, providing CAS aircraft hand-off to terminal controllers, relaying threat updates and BDAs, coordinating and deconflicting CAS with other supporting arms, and coordinating fixed- and rotary-wing operations.
- **ASC(A).** The ASC(A) operates from an aircraft to provide coordination and procedural control during assault support operations. The ASC(A) is assigned by the ACE commander and plays a critical role during multiple, independent assault support operations or large, complex operations. The ASC(A) is a component of the NTACS/MACCS and is an airborne extension of the DASC or helicopter direction center (HDC). ASC(A) duties include aiding in airspace coordination and integration of assault support operations when DASC/HDC operations are degraded or require augmentation; supporting initial assaults, follow-on assaults, or other assault operations; supporting the air mission commander (AMC) by coordinating movement of aircraft through the C2 system and assigned airspace; and coordinating with the TAC(A) or FAC(A) to provide CAS to the AMC during combat assault transport and other assault support operations.

## COMMUNICATIONS

Information exchange by tactical communication means is necessary to facilitate CAS and allow the proper control of CAS events. Communications must be mission-tailored and robust to ensure that links between aircraft and ground units are maintained and to minimize the chance of fratricide and enhance mission effectiveness. Flexibility and responsiveness of CAS communications is made possible by using a variety of techniques, including secure, frequency-agile equipment; appropriate countermeasures; disciplined emission control (EMCON); and standard communications nets.

### Secure Voice/Frequency-Agile Communications

The standard mode for all CAS communications should be secure voice, frequency agile (e.g. HAVE QUICK or single-channel ground and airborne radio system (SINCGARS)), and/or data link whenever available. However, the absence of these capabilities should not be allowed to hinder the application of CAS, especially in emergency situations or in the case of a time-sensitive target.

### Countermeasures

Enemy communications jamming, monitoring, and imitative deception interfere with the air C2 system and jeopardize the use of CAS. Proper radio procedures are critical. A number of techniques exist to counter jamming and deception. These include natural terrain masking, burn through, brevity, chattermark procedures, frequency-agile radios, secure communications, authentication, and visual signals. No single technique is completely effective by itself. The

tactical environment, available communications equipment, and the mission determine the proper techniques to be used.

### **Emission Control**

EMCON should be emphasized throughout the planning and training cycles. As the enemy increases the use of electronic attack (EA), traditional air support communications may become difficult. This may reduce an aircrew's ability to conduct immediate missions. However, a preplanned mission can be accomplished with minimum communication between the terminal controller and the aircrew. CAS planning should include the identification of alternate communication methods to coordinate, request, and control CAS.

On a preplanned CAS mission with high enemy EA activity, the DASC or TAC(A) can transmit the CAS brief to the aircrew before initial contact with the terminal controller. The aircrew would contact the terminal controller, transmit the abort code, and receive the time on target (TOT) or time to target (TTT). Once this is accomplished, both the controller and the aircrew have the minimum coordinating information required to accomplish the preplanned attack.

Another example is a preplanned, scheduled mission with no direct contact anticipated between the terminal controller and the aircrew. The aircrew uses previously coordinated information, normally from the supported unit's tactical airstrike request, with a TOT to conduct the attack. All participants—aircrew, terminal controller, DASC, FSCC, artillery—must use the same timing method. The best timing method is the synchronized clock. With the proliferation of ground and air global positioning systems (GPSs), the use of GPS time has become more prevalent and is the preferred timing synchronization method. If a synchronized clock is not available, the terminal controller can pass a TTT to the aircrew once they are airborne.

## MAGTF Close Air Support Communications Nets

Standard communications nets are used by air control agencies and tactical aircraft in the conduct of CAS. In addition to these standard nets, numerous alternative nets also exist within the C2 systems, and these alternative nets could be used in extreme situations. Alternative nets are designed to provide communications redundancy. See figure 2-2 on page 2-14 for a listing of the standard communications nets associated with CAS.

- **Direct Air Support Net.** This net provides a means for the DASC to request direct air support aircraft from the TACC/TADC. Information pertaining to aircraft status and progress of direct air support missions may also be passed over this net.
- **Group Common Net.** This net provides a means of communication between in-flight group aircraft and/or with the aircraft group headquarters. Each aircraft group has its own common net.
- **Guard Net.** This net is the emergency distress net for aircraft. The guard net further serves as a means for air control agencies to advise aircraft of emergency conditions or serious hazards to flight safety. All aircraft continuously monitor the guard net.
- **Helicopter Direction Net.** This net provides positive control of inbound and outbound helicopters in the AOA. It is a backup net that is available to coordinate rotary-wing CAS.



- **Squadron Common Net.** This net provides a means of communication between squadron aircraft and/or with the squadron headquarters. Each aircraft squadron has its own common net.
- **Tactical Air Command Net.** This net provides the primary means by which the TACC/TADC can task aviation groups and squadrons to conduct direct air support, including CAS.
- **TACP Local Net.** This net provides a means for coordination between the AO and his FACs. Coordination with TAC(A)s and FAC(A)s may also be conducted over this net.
- **Tactical Air Direction (TAD) Net.** This net provides a means for the control of aircraft conducting CAS and for the TACC/TADC/DASC to brief CAS aircraft on target information and assignment to the FAC or FAC(A). Multiple TAD nets are required and used by various air control agencies. This net is primarily ultrahigh frequency (UHF), with a secondary very high frequency (VHF) capability available in some cases. The TAD net should be reserved for time-critical terminal control information only.
- **TAR Net.** This net provides a means for ground maneuver units to request immediate air support from the DASC or TACC/SACC. The SACC/FSCCs monitor this net and may approve, disapprove, or modify specific direct air support requests. The DASC uses the net to brief the requesting unit on the details of the mission. Additionally, BDAs may be passed over the TAR net. Multiple TAR nets may be required depending on the extent of CAS operations. A secondary VHF capability may be available.
- **Tactical Air Traffic Control (TATC) Net.** This net provides a means for the TACC/TADC, TAOC, and DASC to exercise control of all tactical and itinerant aircraft in the area of

operations. Types of information passed over the TATC net include aircraft reports of launches by mission number, clearance of aircraft to their assigned control agencies, diverting aircraft as necessary, and relay of in-flight reports and BDA. Multiple TATC nets are often required.

Net	Frequency	TACC	TADC	TAOC	DASC	Marine Aircraft Group (MAG)	TACP	Aircraft
Direct Air Support	HF VHF	X	#		X			
Group Common	UHF					X		#
Guard	UHF VHF	X	X	X	X		X	X
Squadron Common	UHF VHF							#
Tactical Air Command	HF VHF	X X	# X	X	X	X		
TACP Local	VHF				#		X	#
Tactical Air Direction	UHF VHF	X	#	#	X		#	#
TAR	HF VHF	N	#	#	X		X	
Tactical Air Traffic Control	UHF VHF	X #	#	X	X			#
X = Indicates Normal Participation in the Specified Net. # = Indicates Participation When Directed or as Required. N = Indicates Participation by NTACS Agencies.								

**Figure 2-2. MAGTF Close Air Support Communications Nets.**

## **CLOSE AIR SUPPORT COMMAND AND CONTROL FOR JOINT FORCE OPERATIONS**

The JFC normally exercises OPCON through Service component commanders, functional component commanders, or some combination of the two. In joint operations, components should provide and operate C2 systems that have similar functions at each level of command. Joint CAS is controlled by the JAOC and uses the host component's organic C2 architecture. If designated, the JFC, through the JFACC, tasks air assets made available for joint tasking through Service component C2 systems. Figure 2-3 illustrates basic joint force CAS connectivity between service components, the JFC, and the JFACC.

In the case of MAGTF aviation in joint operations, the MAGTF commander will retain OPCON of organic air assets. MAGTF air assets will normally be in support of the MAGTF mission. To support the CAS needs of the joint force, sorties in excess of the MAGTF's direct air support requirements will be provided to the JFC for tasking. For further information, see the "Policy for Command and Control of United States Marine Corps (USMC) TA-CAIR in Sustained Operations Ashore," page IV-4, Joint Pub 0-2, *Unified Action Armed Forces (UNAAF)*.

Figure 2-4 (page 2-17) depicts functional equivalents among the U.S. Air Force theater air control system (TACS), U.S. Army air-ground system (AAGS), NTCAS, MACCS, and special operations C2. See Joint Pub 3-56.1, *Command and Control for Joint Air Operations*, for further information.

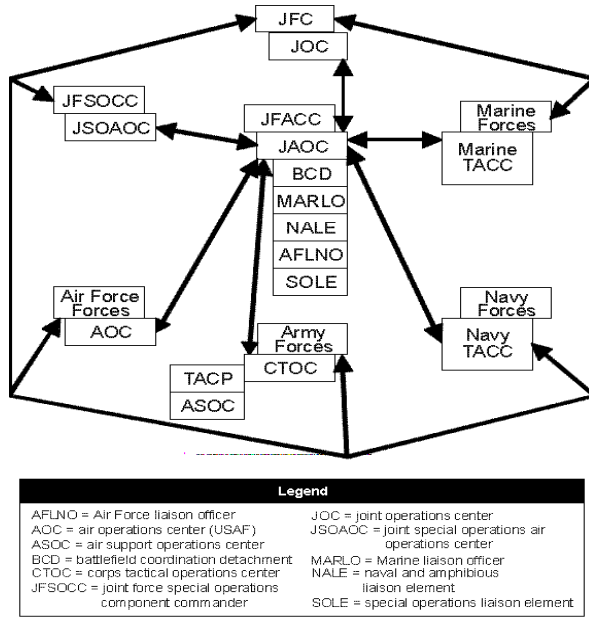

**Figure 2-3. Joint Force Close Air Support Connectivity.**

During joint force operations, a command relationship between land components (e.g. tactical control (TACON), OPCON, attachment, supporting/supported) may or may not exist.

If a command relationship is established between components, the supporting component uses the CAS process of the supported component. For example, if an Army brigade is under the OPCON of a MAGTF commander, the Army brigade directs CAS requests through the brigade fire support element (FSE) to the Marine FSCC and through the MACCS. The Army request is handled the same as any other CAS request in the MACCS.

If a command relationship is not established between components, each component forwards CAS requests using its respective CAS

U.S. Marine Corps	U.S. Army	U.S. Navy	U.S. Air Force	Special Operations Forces (SOF)
TACC TADC	BCD	TACC TADC	AOC	JSOAOC
TADC	—	AWC	CRC	—
DASC	—	ASCS HCS	ASOC	SOCCE
FSCC	FSE A2C2	SACC	—	—
TACP	—	—	TACP	SOIF
FAC(A)	—	FAC(A)	FAC(A)	—
TAC(A)	—	TAC(A)	TAC(A)	—
FAC	—	—	FAC	SOTAC

Legend	
A2C2 = Army airspace command and control	FSE = fire support element
AOC = air operations center (USAF)	HCS = helicopter control section
ASCS = air support control section	SOCCE = special operations command and control element
AWC = air warfare commander	SOTAC = special operations terminal attack controller
CRC = control and reporting center	

request process. Joint CAS requests are forwarded to the JAOC for consideration and assignment. For example, if a MAGTF and an Army division are operating as adjacent units under a JFC, each

component would direct requests for joint CAS through its respective request process to the JAOC.

### **Figure 2-4. Component Air Command and Control Agency Functional Equivalents.**

## **Joint Communications Requirements**

Aircrews performing joint CAS will use the communications nets and architecture of the supported component. To ensure that joint CAS is executed properly, all components involved must have the appropriate signal operating instruction (SOI)/communications-electronics operating instruction (CEOI) data to communicate effectively and successfully support requesting units. The joint force communications manager (J-6) must determine the standard SOI/CEOI information needed and ensure that it is provided to all components. It is the responsibility of the JFACC/JFC staff to ensure that required communications data for CAS is published in the joint ATO. It is the responsibility of component commanders to have and maintain the designated keymat for secure communications.

CAS-capable units, aircrews, terminal controllers, and air control agencies will need radio frequencies and call signs that are specific to joint CAS C2. CID means, such as identification, friend or foe (IFF) codes and authentication materials, will also be required. The MAGTF communications manager (S-6) should establish direct liaison with the joint force J-6 to coordinate the necessary CAS communications data needed to support the joint CAS process. See Joint Pub 3-09.3, *JTTP for Close Air Support (JCAS)*, for further information.

## **Chapter 3**

# **Planning**

The CAS planning process involves a number of interdependent activities. Because battlefield situations and the information available about them are constantly changing, CAS plans must be continually adapted as time allows. In this way, the CAS planning process can build on itself with each step to create a new understanding of the situation. CAS planning should be considered a continuous learning activity that facilitates the exercise of judgment and not a fixed mechanical procedure.

### **SECTION I. BASIC CONSIDERATIONS**

#### **CLOSE AIR SUPPORT EMPLOYMENT PLANNING**

CAS is a cyclic process marked by concurrent, parallel, and detailed planning. The MAGTF commander plans for the employment of CAS throughout the battlespace in deep, close, and rear operations. The decision to use CAS is based on subordinate unit missions and their need for support. Commanders consider the requirement for CAS throughout their areas of operations based on their scheme of maneuver and concept of operations.

Any element of the MAGTF may be designated the main effort to accomplish a critical task, and CAS may play an important role in the combined-arms approach to accomplishing the task. Once the time and place for decisive maneuver by the GCE is determined,

CAS will require full integration into the plan. Therefore, the preponderance of CAS and the priority of fire support will normally be allotted to the main effort.

Timing should also be considered when planning CAS employment. Used too early, CAS aircraft may be forced to disengage before mission completion because of low fuel or ammunition; employed too late, CAS aircraft may miss part or all of the intended target and fail to have the desired effect. CAS planning must also account for the requirement to have qualified and proficient terminal controllers to ensure effective target attacks and to minimize fratricide.

### **Deep Operations**

CAS employment planning for deep operations may include supporting reconnaissance forces or conventional forces with a deep operation mission. CAS in support of forces conducting deep operations is normally planned to be limited in scope and duration and to support attacking maneuver forces or special operations activities. Deep operations involving CAS may require additional coordination to deconflict with deep air support missions, such as air interdiction or armed reconnaissance.

### **Close Operations**

The commander generally assigns most of his available CAS to the unit designated as the main effort. CAS aircraft and other fire support assets are postured to concentrate fires in support of the main effort. CAS is also a valuable asset for exploiting tactical success and pursuing a retreating enemy.

### **Rear Operations**



Rear operations CAS is planned to counter deep enemy attacks against support forces operating in the friendly rear area. The responsiveness and firepower provided by CAS can greatly augment the combat power of rear area forces. The potential for fratricide is high in the rear area because of the larger number of support personnel and activities located in this area. CAS aircrews and terminal controllers must take special care to identify friendly forces and ensure that they are not harmed by CAS ordnance delivered against enemy forces.

### Offensive Employment

CAS assists offensive operations with preplanned or immediate missions. This gives the MAGTF commander freedom of movement by delivering a wide range of ordnance and by destroying or neutralizing enemy forces. CAS planning for offensive operations depends on the type of offensive operation being conducted.

- **Movement to Contact.** CAS missions can be planned to support maneuver forces providing forward and flank security. Once contact is made, using CAS aircraft at the initial point of contact can overwhelm the enemy and force a premature deployment of his forces. CAS aircraft performing security missions maneuver according to the location or movement of the main body and known or suspected enemy units. Execution orients on rapid location of enemy forces and rapid development of the situation, engaging as necessary to ensure adequate time and space for friendly forces to gain positional advantage and seize the initiative. CAS may also be employed in the conduct of reaction force missions that support movement-to-contact operations. CAS aircraft performing reaction force support missions also

maneuver according to the location of the main body, but they maintain positions displaced from the planned or suspected engagement area until contact is made.

- **Attack.** Commanders plan for and use CAS to support attacks against enemy forces. CAS can destroy critical enemy units or capabilities before the enemy can concentrate or establish a defense. CAS can also fix the enemy in space or time to support the movement and assault of ground forces. CAS adds to the concentration of firepower, the shock effect, and the violence against the enemy. CAS can help to isolate enemy forces on the battlefield and force the enemy to defend in a direction from which he is unprepared to fight. CAS is incorporated into the detailed planning and coordination involved in a deliberate attack.
- **Exploitation.** Exploitation is an offensive operation that usually follows a successful attack and is designed to disorganize the enemy and erode his cohesion. In exploitation, CAS is planned to sever escape routes, destroy fleeing forces, and strike unprotected enemy targets that present themselves as enemy cohesion deteriorates.
- **Pursuit.** In the pursuit, the commander attempts to annihilate the fleeing enemy force as the enemy becomes demoralized and his control disintegrates. Because the objective of the pursuit is destruction of the enemy, CAS can keep direct pressure on the enemy to prevent him from reorganizing or reconstituting.

## Defensive Employment

CAS is inherently offensive in nature, but it can also be effectively employed to support the defense. In defensive operations, CAS can be planned and used to cause the enemy to deploy prematurely, to deny the enemy access to critical terrain for a specified time period, or to slow or stop the enemy's attack. CAS can be assigned to support both the mobile and the positional elements of the defense. Commanders may plan the use of CAS in the defense to:

- **Support Maneuver.** CAS complements maneuver forces and integrates with surface-delivered fires as part of a combined- arms attack.
- **Support Movement.** CAS supports the movement of friendly forces between positions.
- **Attack Penetrations.** CAS engages enemy units that have bypassed main battle area forces or penetrated friendly positions.

### Reserve

In offensive operations, CAS can provide the ground commander with additional firepower to reinforce or exploit success. In defensive operations, CAS can provide a supported commander with highly mobile firepower to counterattack or support counterattack forces.

### Alert Status

Aircraft may be placed on ground alert or launched into an airborne alert orbit near the battle area. Alert aircraft must be configured

with weapons and ordnance appropriate for anticipated targets; if different kinds of targets are encountered, the aircraft and its weapons may be less effective. Airborne alert aircraft consume fuel as they orbit, and these aircraft eventually will have to be used or must depart to be refueled. Regularly scheduled aerial refueling can increase both the combat radius and time on station for fixed-wing aircraft if tankers can be suitably positioned.

### **CLOSE AIR SUPPORT MISSION PLANNING**

Upon receipt of the mission, aircrews begin detailed mission planning. Aircrews select tactics and techniques that offer the best chance of mission success and accomplishment of the assigned task. The commander's intent is relayed as the purpose of the mission, which allows planners to adapt to changing situations and to exercise initiative throughout the process. Mission tactics and techniques must be flexible, innovative, and unpredictable. Aircrews conduct detailed mission planning to:

- Determine the required tactics
- Identify support requirements
- Coordinate the use of fire support, EW support, and C2.

Basic CAS planning begins with an analysis of mission, enemy, terrain and weather, troops and support available, and time available (METT-T). Additional factors will determine the tactics and techniques required to conduct a particular CAS mission. Appendices A and B outline additional CAS planning considerations.

- **Mission.** Planners study the mission to understand their objective, the specified and implied tasks to be performed in accomplishing the objective, and the supported commander's intent or purpose for conducting the mission. Understanding the mission's purpose is key, for it allows supported and supporting units the latitude to exercise initiative and exploit opportunities. In planning CAS missions, the FAC, or AO and aircrew, should understand the ground commander's objective, scheme of maneuver, C2 requirements, and criteria for specific rules of engagement (ROE). This understanding increases overall situational awareness by all participants and facilitates the initiative required to maximize CAS effectiveness.
- **Enemy.** By determining key enemy characteristics, such as composition, disposition, order of battle, capabilities, and likely courses of action (COAs), planners begin to formulate how CAS can best be used. Other considerations are the enemy's capability to conduct command and control warfare (C2W) and the potential or confirmed presence of chemical or biological contamination. From this information, CAS planners anticipate the enemy's ability to affect the mission and the potential influence enemy actions may have on flight tactics and techniques.

As the threat level increases, prebriefing of aircrews and detailed mission planning become critical. The potential for the threat situation to change during the course of the mission makes communications and close coordination between the aircrews, control agencies, and the supported ground force crucial. In-flight updates on enemy activity and disposition along the flight route and in the target area may require the aircrews to alter their original plan and tactics. If the enemy is successful at disrupting communications, alternatives are planned to ensure mission accomplishment. Secure-voice equipment and frequency-agile radios can overcome some effects of enemy interference.

- **Terrain and Weather.** A terrain survey is used to determine the best routes to and from the target area. Where the terrain permits and when the threat dictates, flight routes should maximize the use of terrain masking to increase survivability against air defense systems. When practical, flight routes, holding areas, initial points (IPs), release points, and battle positions (BPs) should use terrain features that are easily recognizable, day or night. Broad area satellite imagery and air mission planning and rehearsal systems can assist in selecting optimum flight parameters.

Weather plays a significant role in CAS operations. It influences both enemy and friendly capabilities to locate, identify, and accurately attack CAS targets. Weather can also influence the effectiveness of laser designators, precision-guided munitions (PGM), night vision devices (NVDs), and thermal imaging systems. Planners at every level require an understanding of the effects that weather can have on CAS aircraft navigation, sensors, and weapons systems.

- **Troops and Support Available.** Knowledge of friendly force troop location and movement is paramount. CAS operations must be fully integrated into the supported commander's scheme of maneuver and the fire support plan. Ideally, the support required to conduct a CAS mission is identified early in the planning process. Support for the CAS mission can then be requested with sufficient time to coordinate its use. CAS mission support requirements that must be determined include escort, EW, SEAD, tankers, reconnaissance, and C2 systems.
- **Time Available.** Time is the critical element in coordinating events and massing fires to achieve the combined-arms effect of ground and aviation forces. Adequate time must be available to ensure mission success. CAS planners must estimate the amount of time necessary to plan the mission, effect the necessary

coordination, and execute the mission. Inadequate time management may result in reduced effectiveness and increased risk to aircrews and ground troops.

## Target Considerations

The battlespace can contain a large variety of targets. The type and characteristics of these targets may differ greatly. The following target considerations are used when selecting attack tactics and ordnance:

**Visibility.** Visibility is more critical for long-range deliveries (e.g., free-fall bombs/rockets) than it is for short-range deliveries (e.g., retarded bombs and guns). Thick haze or smoke has a greater effect on low-level attacks than on steep-dive attacks because horizontal visibility is usually lower than oblique visibility. If enemy vehicles are moving, exhaust smoke, dust trails, and movement can indicate their location. Poor visibility can restrict laser and electro-optically guided ordnance. Target acquisition is usually easier when the sun is behind the aircraft.

- **Target Masking.** A target screened by valleys or other natural cover may be difficult to see on low-level attacks. An increase in altitude may be necessary to find the target.
- **Thermal Significance.** Many variables can affect a target's vulnerability to detection and attack by thermal systems. Recent operating conditions, time of day (thermal crossover), and target composition and background should all be considered.
- **Contrast and Brightness.** A major factor in target detection is the contrast of the target against its background. Camouflaged targets against a background of similar color may be impossible

to detect. All targets, regardless of contrast differences, are more difficult to locate under poor light conditions.

- **Target Defenses.** Valuable enemy targets are usually defended by surface-to-air missiles (SAMs), anti-aircraft artillery (AAA), or automatic weapons. Losses from enemy air defenses incurred while attacking high-value enemy targets are minimized by reducing exposure times, jinking, using “stand-off” capable weapons, and employing EW.
- **Accuracy Versus Survivability.** Low-level tactics attempt to increase mission success by decreasing exposure to enemy air defenses. Additionally, greater firing accuracy is achieved by reducing the distance between the aircraft and the target. However, the lower an aircraft is and the closer it is to a target, the greater its potential vulnerability to other types of surface-to-air weapons (SAWs), indirect fire weapons, and small arms fire.
- **Weather.** Weather conditions are one of the most critical factors in visual attacks. Weather, as well as the position of the sun or moon, affects contrast and can prevent target acquisition by aircrews or the use of electro-optically guided ordnance. These same considerations also affect enemy air defense weapons that use optical sights. Rain and snow reduce visibility and can prevent an attack. Incorrectly assessed wind velocity can result in delivery errors.

## **CLOSE AIR SUPPORT NAVIGATION PLANNING**

### **Coordinate Systems**

Several different coordinate systems and datums are used around the world, even within U.S. forces. The use of multiple datums has led to inaccuracy and confusion during combat operations. The use



of a common datum reference in the CAS process is essential and should be prescribed by the JFC or MAGTF commander. If the MAGTF commander does not designate a standardized datum or if there is any doubt about which datum is being used, units requesting CAS should specify the datum in the JTAR.

Currently there are 32 separate datums used in map production around the world. Many of these datums have several different ellipsoids. Although the long-term U.S. goal is to eventually refer to all geographic positions on the World Geodetic System, or a compatible ellipsoid, there are still 11 different ellipsoids used on U.S.-produced maps:

- Australian National or South American 1969
- Bessel 1841
- Clarke 1866
- Clarke 1880
- Everest
- Geodetic Reference System 1980
- International
- Modified Airy
- Modified Everest
- World Geodetic System 1972
- World Geodetic System 1984.

## Aircraft Systems

Not all aircraft involved in the CAS process use the same coordinate reference system in their navigation systems. Variations exist in the ways different aircraft types use the military grid reference system (MGRS), the universal transverse mercator (UTM), latitude/longitude, and radar offset data. The standard for target location is MGRS/UTM (6 digit) grid coordinates; however, latitude/longitude may be requested if required by a particular aircraft's system. Many GPS receivers can compute quick, accurate coordinate conversions, if users are properly trained.

It is important to note that the MGRS is not identical to the UTM. Both are based on meters, but each will give a different prefix (number, or number and letter combination) to indicate distance from the equator. However, the last five digits of MGRS and UTM coordinates (nearest 1 meter) of easting and northing are identical. For example, Naval Air Station Oceana, Virginia, in MGRS is "18S VR 07791 75465," and in UTM is "18 407791 4075465." See Appendix C for specific aircraft navigation capabilities and coordinate reference system requirements.

## CLOSE AIR SUPPORT LOGISTIC PLANNING

Preparing weapons, configuring aircraft, and scheduling tankers for aerial refueling requires time and coordination. The more specific and timely a CAS request, the higher the probability the allocated aircraft will be appropriately armed for the mission. Logistic efforts must ensure CAS is timely and responsive to adequately support the ground commander's scheme of maneuver.

## Basing Modes

CAS aircraft may be operationally based in a number of ways. The more traditional basing modes include main operating bases on land and seabasing aboard naval ships afloat. Fixed-base and shipboard deployment generally offer the widest range of available ordnance, mission equipment, logistic support, and so on, but these locations are often well removed from the battle area. As a result, aircraft may have farther to fly to reach CAS target areas and have a longer turnaround time between missions. In addition to using main operating bases and ships, aircraft can be deployed to FOBs.

## Forward Operating Bases

Forward deployment of CAS aircraft offers several advantages. Operating from locations close to the battle area can increase loiter time in the objective area, extend effective combat radius, and, perhaps most importantly, make the CAS firepower more responsive to ground commanders by shortening the response time. Preplanned logistic support is vital to ensure that sufficient ammunition, fuel, and servicing equipment are in position and ready for use when needed.

- **Responsibilities of Supported Units.** Supported units should provide a forecast of anticipated CAS targets, so that appropriate munitions can be transported to FOBs and prepared for use.
- **Responsibilities of Supporting Units.** Supporting units are responsible for keeping FOBs operational by planning for and carrying out logistical support. FOB logistical support is a function of the number and type of aircraft that use the location, operations tempo, quantity and type of munitions employed, and system-specific support requirements.

## Forward Arming and Refueling Points

CAS aircraft can be supported through forward arming and refueling points (FARPs) located in the forward area. (See figure 3-1.) The FARP extends the effective combat radius of CAS aircraft, facilitates their responsiveness, and increases their time in the objective area. Rapid ground refueling (RGR) by appropriately equipped aircraft can also provide these same advantages. Preplanned logistic support is vital to ensure that sufficient ammunition and fuel, as well as the proper servicing equipment, are available when needed.

- **Support to FARPs.** Like FOBs, logistical support to FARPs is a function of the number of aircraft planning to use the FARP, the tempo of operations, the types of munitions to be employed, and other system-specific support requirements. There are aircraft-unique equipment requirements (e.g., munitions handling equipment) that must be addressed. As a minimum, CAS aircraft operations require the following coordination:
  - Number and type of aircraft staging through the FARP
  - Munitions, including weapon- or aircraft-specific munitions handling and support requirements
  - Petroleum, oil, and lubricant support, including specific needs
  - Sequencing (timing) of aircraft through the FARP
  - FARP security
  - Marine air traffic control mobile team (MMT) support.

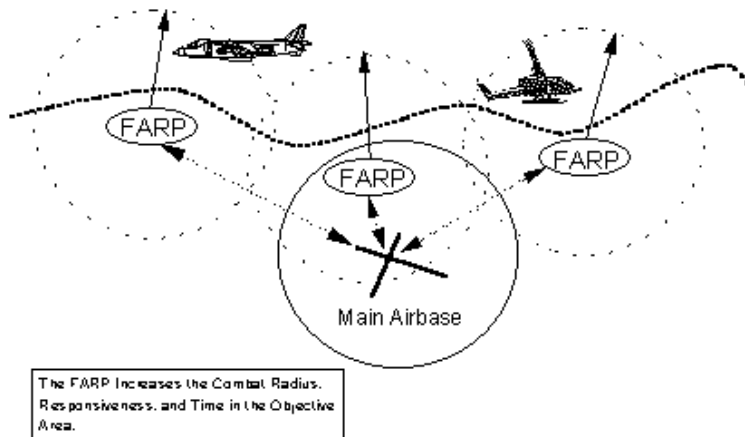

**Figure 3-1. Forward Arming and Refueling Points.**

## **SECTION II. CONTROL AND COORDINATION MEASURES**

Commanders can employ a variety of measures to control and coordinate airspace and airspace users. The senior air control agency is responsible for deconflicting air operations by establishing control procedures to ensure the efficient and safe use of airspace. In joint operations, the airspace control authority deconflicts the airspace by publishing the airspace control plan and the subsequent airspace control orders. The air and ground commanders coordinate the use of control procedures to strike a balance between the ground force use of airspace and protection of aircraft using that airspace. Control and coordination procedures include airspace control measures and fire support coordination measures (FSCMs).

### **AIRSPACE CONTROL MEASURES**

Airspace control measures increase operational effectiveness. They also increase CAS effectiveness by ensuring the safe, efficient, and flexible use of airspace. Airspace control measures speed the handling of air traffic within the objective area. Air C2 systems use airspace control measures to help control the movement of CAS aircraft over the battlefield. Airspace control measures are not mandatory or necessary for all missions.

### **Control Points**

Control points route aircrews to their targets and provide a ready means of conducting fire support coordination. Control points should be easily identified from the air and should support the MAGTF's scheme of maneuver.

The senior FSCC and the ACE select control points based on MAGTF requirements. Appropriate MACCS agencies ensure that command and control issues are addressed during control point selection. The selected control points are then sent to the MAGTF commander for approval.

During amphibious operations, the MAGTF AO sends the MAGTF's list of control points to the ATF commander. The SACC analyzes the control points to determine their effect on other fire support means. The Navy TACC also reviews the selected control points. Once the control points are approved, the list is published in the air annex to the operation order (OPORD). Additions or changes to control points listed in the air annex are approved in the same manner as the original control points.

### **Multiuse Control Points**

If possible, control points should be usable by a variety of aircraft. The Marine TACC identifies the specific use for each control point as the tactical situation dictates. The ATO states the control points' daily intended use. The following paragraphs identify multiuse control points. Figure 3-2 provides an example of multiuse control points used for a CAS mission.

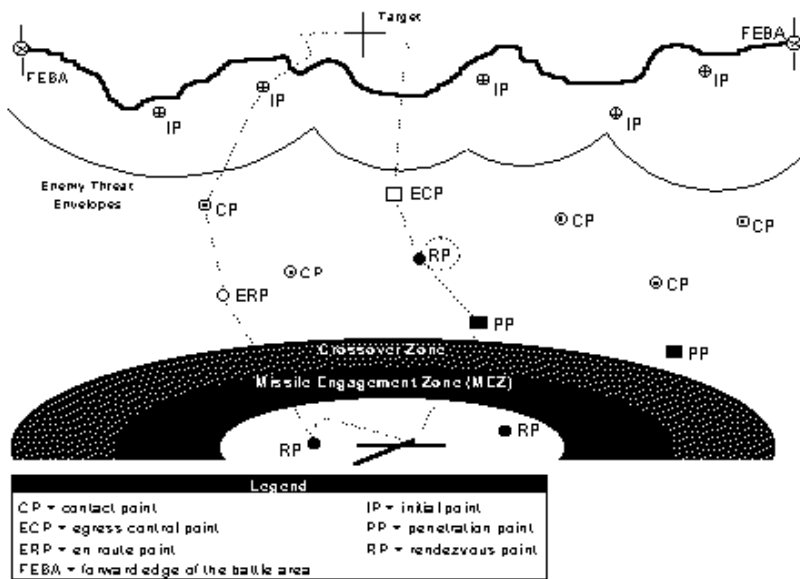

**Figure 3-2. Example of Multiuse Control Points for a Close Air Support Mission.**

- **Entry Point/Exit Point (EP).** EPs are used to enter/exit the AOA. At EPs, the aircrew must contact the TACC (Navy or Marine) for further clearance.
- **En Route Point (ERP).** ERPs are used to define routes of flight to and from the target area. ERPs allow specific routing of aircraft for C2, airspace limitation, or ROE requirements. For the ingress routes, ERPs are placed between the rendezvous point (RP) and the contact point (CP). For the egress routes, the ERPs are placed between the egress control point (ECP) and the penetration point (PP).



- **Orbit Point/Holding Point.** Orbit points and holding points either represent geographic positions or are defined and fixed by electronic means. These points are used to station aircraft inside the AOA, keeping them in a specific area of airspace while they await further routing instructions. An orbit point is used during tactical operations when a predetermined pattern would be predictable and therefore is not set. A holding point prescribes a predetermined pattern and is normally used while awaiting air traffic control clearances. A control point can be dual-designated as both an orbit point and a holding point, although orbit points and holding points are usually separate and distinct locations.
- **CP.** A CP is “the position at which a mission leader makes radio contact with an air control agency.” (Joint Pub 1-02) Normally, a CP is outside the range of enemy SAWS and is 15-30 nautical miles (NM) from the IP. During ingress, the aircrew contacts the terminal controller at the CP. A CP allows coordination of final plans before entering heavily defended airspace.
- **IP.** The initial point is “used as the starting point for the bomb run to the target.” (Joint Pub 1-02) IPs are well defined and easily identified (visually or electronically) and are located 5-15 NM from the target area. Terminal controllers and aircrews use IPs to help position aircraft delivering ordnance.
- **RP.** An RP is a prearranged geographic location where aircraft meet after takeoff or after exiting the target area.
- **ECP.** An ECP is a well-defined geographical control point outside the enemy air defense area. The ECP identifies a CAS aircrew’s egress from the target. Contact with terminal controllers normally ends at the ECP. The DASC is the overall coordinator for the ECP. A FAC, FAC(A), or TAC(A) can control the ECP. An aircrew can use an ECP as a secondary CP to start a second attack.

- **PP.** A PP is used for reentry into the friendly air defense network. PPs are located beyond the intercept zone of the friendly SAM network. Aircraft with operating identification, friend or foe (IFF) equipment or communications with the TAOC continue with their recoveries from the PP. Aircraft without IFF equipment or communications execute prebriefed identification procedures at or before the PP or wait at the PP for rendezvous with friendly escort aircraft.

**Note:** The PP is different from a penetration control point. A penetration control point is used to cross a hostile coastline during amphibious helicopterborne operations.

### Rotary-Wing Control Points

In addition to multiuse control points, there are rotary-wing-specific control points. Figure 3-3 provides an example of control points that are unique to rotary-wing CAS planning and employment.

- **Holding Area (HA).** The HA is occupied while awaiting targets or missions. While in the HA, aircrews receive the CAS briefing and perform final coordination. Aircrews can receive updated target or mission information in a face-to-face brief or over the radio. After receiving the brief, aircrews move along attack routes (ARs) to BPs or individual firing points (FPs).
- HAs can be located near regimental or battalion headquarters to take advantage of their communications connectivity. Terminal controllers can also locate HAs at their position.

**Figure 3-3. Rotary-Wing Control Points.**



communications for coordinating a launch. The availability or use of messengers should also be considered and planned for.

- **BP.** The BP is an airspace coordination area that contains firing points for attack helicopters (Marine Corps Reference Publication (MCRP) 5-2C draft, *Marine Corps Supplement to the DOD Dictionary of Military and Associated Terms*). FPs are normally positioned laterally and in-depth. BPs should allow good cover and concealment, provide necessary maneuvering space, allow for appropriate weapons engagement zones (WEZs), and be reasonably easy to identify. BP selection begins during premission planning. A coordinated effort between air and ground units in the selection of BPs is optimal. Maneuvering time spent in the BP should be minimal to prevent detection and engagement by the enemy. Once the terminal controller clears aircraft into a BP, flight outside of the BP to attack or to egress is not authorized unless cleared by the terminal controller. Uncoordinated egress from the BP may interrupt other supporting fires and endanger CAS aircrews. Aircraft have freedom of movement within the BP unless restricted by the CAS aircraft flight leader. To avoid enemy counterfire, the CAS aircraft may need to displace and resume the attack from a different BP. Therefore, alternate BPs should be established. Often rotary-wing aircraft use BPs in the same manner that IP fixed-wing CAS runs use IPs. BP-to-target distances in these instances will vary depending on the threat, terrain, and weapons systems available. BP selection is based on the following:
  - **METT-T/Supporting Arms Deconfliction.** The BP must support the mission requirements and be integrated into the scheme of maneuver. It must provide deconfliction with gun-target lines and fixed-wing attack profiles. It must also

ensure that potential BPs are examined for communications limitations.

- **Adequate Maneuver Area.** The BP must be large enough to contain the CAS aircraft and provide safe and flexible maneuver between various FPs. It must provide flexible delivery profiles to ensure accurate weaponeering by the CAS flight.
- **Prevailing Wind.** Wind will affect target marks and artificial illumination and may obscure follow-on targets if the first target engaged is upwind from the remaining targets. To maintain the element of surprise and to minimize acoustic signature detection, the BP can be located downwind from the target. However, aircraft remaining downwind after the initial target engagement could experience target obscuration from blowing dust and debris resulting from ordnance detonation and secondary explosions.
- **Visibility and Sensor Performance.** Target area visibility, and its associated effect on sensor performance, will influence the BP range to target. Fog, smoke, smog, low-lying clouds, and haze can degrade laser/IR sensors and weapons systems such that BP-to-target ranges may have to be significantly decreased for effective employment.
- **Target Altitude.** The BP should be at an elevation equal to or higher than the target area to allow for unobstructed weapon-to-target lines.
- **Terrain Relief.** Hilly and mountainous terrain enables the CAS aircrew to mask/unmask easily and aids in navigation. If a radar threat is expected in the objective area, the radar's capabilities should be examined to determine if acquisition is possible at the CAS aircraft's operating altitude.

- **Range.** BPs should be located so that the target area is within the effective WEZ of the aircraft's weapons systems. The BP should be outside the threat's WEZ, unless terrain masking and/or SEAD is available.
- **Field of Fire.** BPs should permit unobstructed sighting of targets throughout the target area. When laser weapons are to be employed, the BP's location must allow for appropriate laser employment geometry and account for safety restrictions.
- **Beaten Zone Optimization.** If area munitions deliveries (rockets/guns) should be required, the maximum amount of the target area should be covered by the beaten zone of the weapons. The BP should be positioned on axis with the long axis of the target area.
- **Sun/Moon.** If possible, the sun or moon should be behind or to the side (night time) of the attacking aircraft. This allows the CAS aircrew to view the kill zone and prevents the enemy from seeing and targeting the aircraft.
- **Background.** Terrain features behind the BP prevent the attacking aircraft from being silhouetted against the horizon.
- **Shadow.** If possible, terrain or vegetation should cover the BP with shadows to provide additional masking.
- **Rotorwash.** The BP location should reduce the effects of rotorwash on surrounding terrain (debris, leaves, snow, sand, and dirt).
- **Backblast.** The BP location should reduce the effects of weapon's backblast on surrounding terrain.

- **Jamming Axis.** Jamming axis alignment considers the positions of the jammer, the BP, and the threat. The intended target may, and many times will, lay outside this axis. The appropriate jammer-to-BP-to-threat alignment must be maintained, or the protection offered will be minimal. If the CAS aircraft exit the BP to attack the target, the jammer axis may require realignment to provide optimal protection to the attacking CAS aircraft.

If an approved BP does not exist, aircrews can plan a hasty BP in coordination with the terminal controller. If there is not a properly placed or existing BP, the terminal controller may create a new one. The new BP is identified by grid, by a known point or prominent terrain feature, or by shifting an existing BP. The terminal controller passes the new BP location to the FSCC for coordination.

- **AR.** CAS aircraft use an AR to move from the HA to the BP. Aircrews select primary and alternate ARs for ingress to and egress from the BP. If an airspace coordination area is required, the terminal controller or aircrew coordinates with the appropriate FSCC. The FSCC passes the airspace coordination area to all appropriate agencies. The ideal AR is a corridor that allows aircraft to move into the BP undetected. Detection, even if beyond the range of enemy air defense weapons, removes the advantage of surprise. ARs that run parallel to preplanned targets should be avoided as this may compromise more than one FP. Terrain and vegetation are used to conceal aircraft movement on the AR. Smoke, supporting arms, and EW measures can also conceal aircraft movement and prevent detection.
- **FP.** An FP is a specific point within the BP that a single aircraft occupies while engaging targets. Alternate FPs should be identified so CAS aircraft can displace after the initial engagement. The flight leader determines movement of aircraft within the BP.

Aircrews choose their own FPs even though the supported commander coordinates and controls the location of the BP.

### Control Point Selection

- **Use of Terrain Features.** Advanced navigational equipment available on many CAS-capable aircraft, such as the GPS and the inertial navigation system (INS), can make the navigation process less difficult. Regardless, CAS planners should still select control points at or near significant terrain features.
- **Techniques.** Aircrews do not need to fly directly over a particular control point. However, precise navigation and adherence to control points may be necessary to deconflict with other fires. In the case of system failures, crews will have to use alternative methods of navigation. Furthermore, friction, stress, uncertainty, fatigue, and other factors common in war may complicate the tactical situation for CAS aircrews and terminal controllers. This may require reverting to simpler means of communication and navigation. Basic pilotage and navigation skills remain critical when conducting CAS.

### FIRE SUPPORT COORDINATION MEASURES

Fire support coordination measures (FSCMs) facilitate the rapid engagement of targets and simultaneously provide safeguards for friendly forces. The supported commander establishes FSCMs based on the recommendations of the force fires coordinator (FFC)/fire support coordinator (FSC). The FFC/FSC coordinates all fire support impacting in the area of operations of the supported



commander. Figure 3-4 depicts common permissive and restrictive FSCMs.

Figure 3-4. Fire Support Coordination Measures.

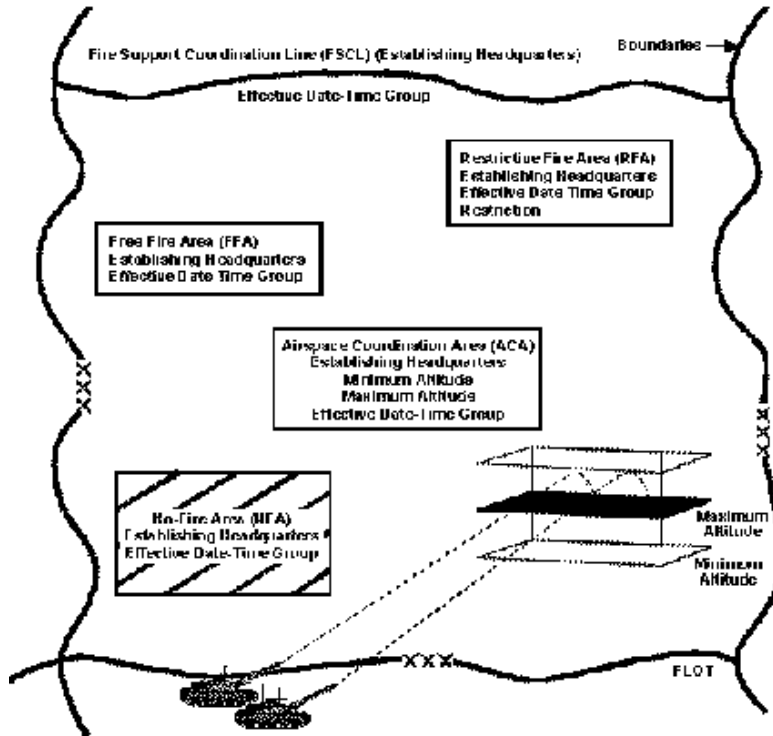

## Permissive Measures

Permissive measures allow the rapid engagement of targets beyond a line or into the area indicated without any further coordination. Permissive FSCMs include:

- **Coordinated Fire Line (CFL).** The CFL is a line beyond which conventional surface fire support means (mortars, field artillery, and naval gunfire ships) may fire at any time within the zone of the establishing headquarters without additional coordination.
- **Fire Support Coordination Line (FSCL).** The FSCL is a line established by the appropriate land or amphibious force commander to ensure coordination of fire that is not under the commander's control but that may effect current tactical operations. The FSCL is used to coordinate fires of air, ground, or sea weapons systems using any type of ammunition against surface targets. The FSCL should follow well-defined terrain features. The establishment of the FSCL must be coordinated with the appropriate tactical air commander and other supporting elements. Supporting elements may attack targets forward of the FSCL without prior coordination with the land or amphibious force commander, provided the attack will not produce adverse effects on, or to the rear of, the line. Attacks against surface targets behind this line must be coordinated with the appropriate land or amphibious force commander.
- **Free-Fire Area (FFA).** The FFA is a specifically designated area into which any weapon system may fire without additional coordination with the establishing headquarters.

## Restrictive Measures

Restrictive measures refer to fires, or the effects of fires, into an area or across a line that must be coordinated with the establishing headquarters or the affected force on a mission-by-mission basis. Restrictive FSCMs include:

- **Restrictive Fire Line (RFL).** The RFL is a line established between converging friendly forces (one or both may be moving) that prohibits fires or the effects from fires across the line without coordination with the affected force.
- **No-Fire Area (NFA).** An NFA is an area into which neither fires nor the effects of fires are allowed. There are two exceptions:
  - When the establishing headquarters approves fires (temporarily) within the NFA on a mission-by-mission basis
  - When an enemy force within the NFA engages a friendly force, the commander may engage the enemy to defend his force.
- **Restrictive Fire Area (RFA).** An RFA is an area in which specific restrictions are imposed and in which fires that exceed those restrictions will not be delivered without coordination with the establishing headquarters.
- **Airspace Coordination Area (ACA).** An ACA is a three-dimensional block of airspace that protects friendly aircraft from friendly surface fires. An ACA can be formal or informal and is an effective means of coordinating air support and surface fire support on the battlefield, thereby allowing commanders to deliver supporting fires over and around this area.

## INTEGRATING CLOSE AIR SUPPORT WITH OTHER FIRES

### Surface Fire Support

One of the most difficult functions performed by an FSCC is integrating CAS with surface fires. The goal is to integrate air support with all other supporting arms and with ground force maneuver to achieve a combined-arms effect. The desire is to accomplish this without suspending the use of any of the supporting arms or unnecessarily affecting the scheme of maneuver. An additional goal is to offer a reasonable measure of protection to aircraft from the unintended effects of friendly surface fires.

- **Inform Supporting Arms Units.** When CAS is requested, the FSCC of the requesting unit (battalion, regiment, or division) informs other concerned FSCCs and all supporting arms units of details of the mission as quickly as possible. The aircraft's time of arrival on station and TOT or TTT is passed on. TOT/TTT is the desired CAS ordnance impact time. Aircraft may also be given a time block in which to conduct CAS attacks (e.g., 1200-1230Z). CAS aircraft conduct attacks within this time block to meet the TOT/TTT. TOT is expressed in terms of a synchronized clock at full minute increments, normally with reference to the current hour omitted (e.g., "TOT is 05," which indicates five minutes past the closest hour). TOT can also be provided in reference to a previously scheduled event, such as an H-hour (e.g., "TOT is H-02," which indicates two minutes before H-hour). TTT is expressed as the number of minutes and seconds required to elapse before ordnance impact. The clock start time is provided by the terminal controller and referred to as a time "hack."

- **Surface Fires Supporting Close Air Support Missions.** There are two primary forms of surface fires that support the conduct of CAS missions: target marking and SEAD. They are often used in combination.

### Target Marking

A target mark should be provided for CAS aircraft whenever possible. A target mark should be planned to include sufficient time before weapons employment to ensure target acquisition by the CAS aircrew. When one of the following marking methods is not possible, the CAS target may be identified by a “talk-on” description provided by the terminal controller. The talk-on may be enhanced by the terminal controller marking his position with devices such as strobe lights, mirrors, or air panels. The target mark can be provided by:

- Indirect fire weapons (mortars, artillery, or naval gunfire)
- Direct fire weapons (tank main gun or machine guns)
- Laser designators
- FAC(A) aircraft (e.g., laser devices, infrared (IR) devices, rockets, GPS)
- IR pointers
- Combined GPS-derived grid and laser spot
- Visual talk-on.

## Suppression of Enemy Air Defenses

The objective of SEAD is to allow friendly aircraft to operate in airspace defended by an enemy air defense system. This involves the suppression of air defense weapons that can threaten friendly aircraft in the immediate vicinity of the target and on ingress and egress routes. Effective SEAD depends on accurate intelligence concerning the location and types of enemy weapons.

- **Surface-Delivered SEAD.** Surface-delivered SEAD involves planning and coordination by the FSCC along with maneuver units down to the company level. Like other suppression missions, surface-delivered SEAD normally requires only a few rounds per target for a short period. The FSC working with the terminal controller and forward observer (FO) coordinate surface-delivered SEAD with target marking.
- **Air-Delivered SEAD.** Air-delivered SEAD and EA must be coordinated and deconflicted to provide necessary support during the time CAS is being conducted.

See MCWP 3-22.2 and Joint Pub 3-01.4 for more information.

## Airspace Coordination Area

Aircraft and surface fire weapons both use airspace in the performance of their missions. What must be avoided is both using the same airspace at the same time. The simultaneous use of airspace by aircraft and surface fire weapons increases the chance for interference and possibly fratricide. An ACA helps in fire support coordination by deconflicting airspace use. ACAs are designed to allow the

greatest freedom of action for air support and surface fire support. An ACA's size and shape depend on:

- Aircraft type, ordnance type, and aircraft delivery profile
- Enemy air defense threat
- Location, range, ordnance type, and trajectory of surface indirect fire support systems.

An ACA can vary from a physically defined area or location to various methods of vertical, horizontal, and time separation or deconfliction. Physically defined areas can include routes (CP to IP, HA to BP) or areas (over the target, IP, BP). Methods of separation or deconfliction include lateral separation, altitude separation, timed separation, or any combination of these.

ACAs are referred to as formal or informal. The method selected depends on the time available, the tactical situation, unit SOP, and the state of training. Because formal ACAs require detailed planning, development of formal ACAs is not always used when time is limited. Informal ACAs are temporary control measures. An informal ACA is an expedient measure designed to provide immediate control and deconfliction. As such, informal ACAs are normally short-lived and not as widely disseminated as formal ACAs. Informal ACAs are also known as separation plans. See MCWP 3-16.2, *Techniques and Procedures for Fire Support Coordination*, for more information on ACAs.

- **Formal ACA.** The airspace control authority or component commanders establish formal ACAs. Formal ACAs require detailed planning. Although not always necessary, formal ACAs should be considered. The vertical and lateral limits established

in an ACA are designed to allow freedom of action for air and surface fire support and consider the greatest number of foreseeable targets. Because only the fire direction center (FDC) can determine the trajectory for a particular battery firing at a specific target, each target must be evaluated to ensure the trajectories of the artillery rounds do not penetrate the ACA. The FSC should consult the FDC when deciding the altitude of an ACA. This coordination will determine if the altitude chosen would allow the majority of targets to be attacked without interference with supporting aircraft operations. (See figure 3-5.)

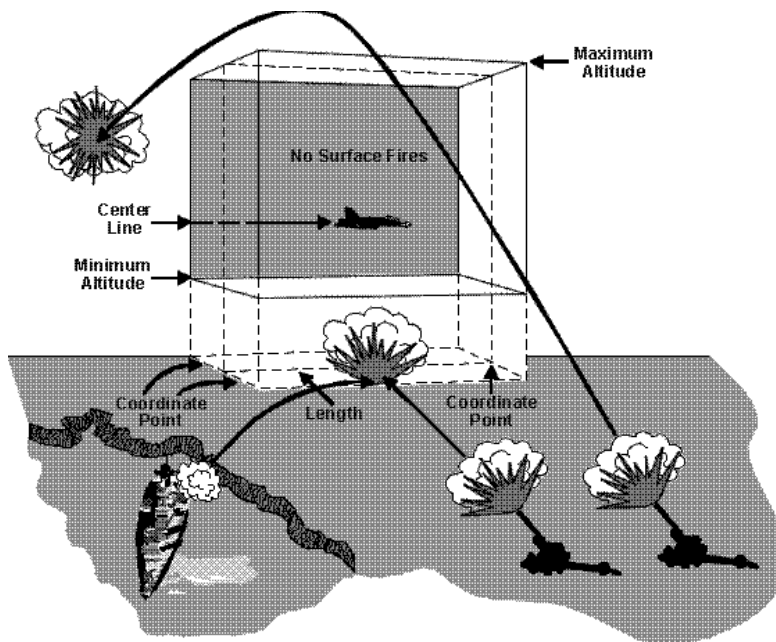

**Figure 3-5. Formal Airspace Coordination Area.**



- **Informal ACA.** Informal ACAs can be designed by using separation plans and are established by the maneuver commander. Aircraft and surface fires may be separated by distance (lateral, altitude, or a combination of lateral and altitude) or by time. Distance separation requires less detailed coordination between aircraft and firing units, but can be the most restrictive for aircraft routing. Fire support personnel should select the separation technique that requires the least coordination without adversely affecting the aircrew's ability to safely complete the mission.
- **Lateral Separation.** (See figure 3-6, page 3-36.) Lateral separation is effective for coordinating fires against targets that are adequately separated from flight routes and ensures that aircraft are protected from the effects of friendly fires. This is an appropriate technique when CAS aircraft and ground firing units engage separate targets; the CAS aircraft will not cross gun-target lines. Lateral distances are based on the probable errors associated with the particular delivery system. Generally, the distances of 600 meters for artillery, 750 meters for naval gunfire less than or equal to 6 inch, and 1000 meters for naval gunfire greater than 6 inch are used for lateral separation. Terminal controllers must know the gun-target line so they can restrict aircraft from crossing trajectories. (For example, the terminal controller description of the ACA could be, "Stay west of grid line 62" or "Remain west of the river.")
- **Altitude Separation.** Altitude separation is effective for coordinating fires when aircraft will remain above indirect fire trajectories and their effects. (See figure 3-7 on page 3-37.) This technique is effective when aircraft and firing units engage the same or nearby targets. (For example, "Remain above 3000 feet mean sea level (MSL) in the quadrant northwest of grid 7325" or "Orbit above 5000 feet mean sea level at Possum Kingdom Lake.")

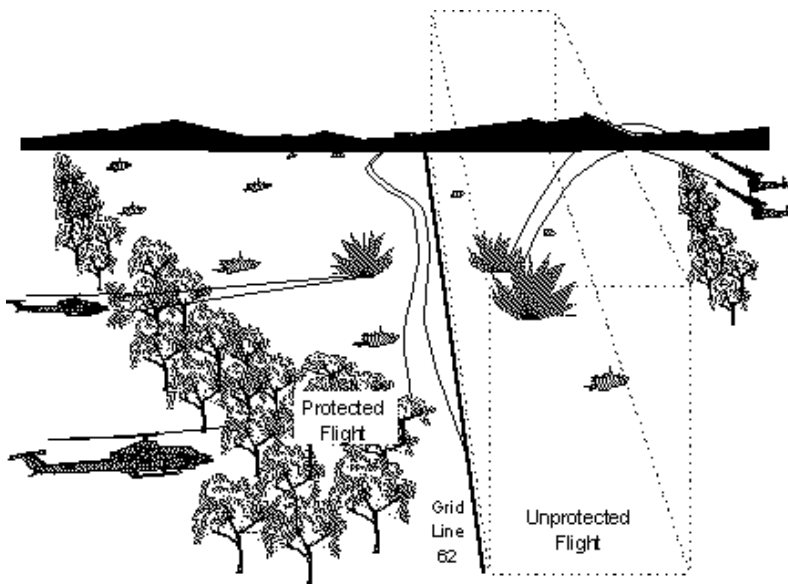

**Figure 3-6. Artillery-Close Air Support Aircraft Lateral Separation.**

- **Altitude and Lateral Separation.** Altitude and lateral separation is the most restrictive technique for aircrews and may be required when aircraft must cross the firing unit's gun-target line. (See figure 3-8 on page 3-38.) This is an appropriate technique when aircraft and firing units engage separate targets and the CAS target is along the gun-target line. This requires CAS aircraft to remain below indirect fire trajectories. Aircraft maneuvering requirements may also dictate that firing units deliver fires by high angle or reduced charge. For example, "Stay between north-south grid lines 58 and 62 and below 3000 feet MSL."

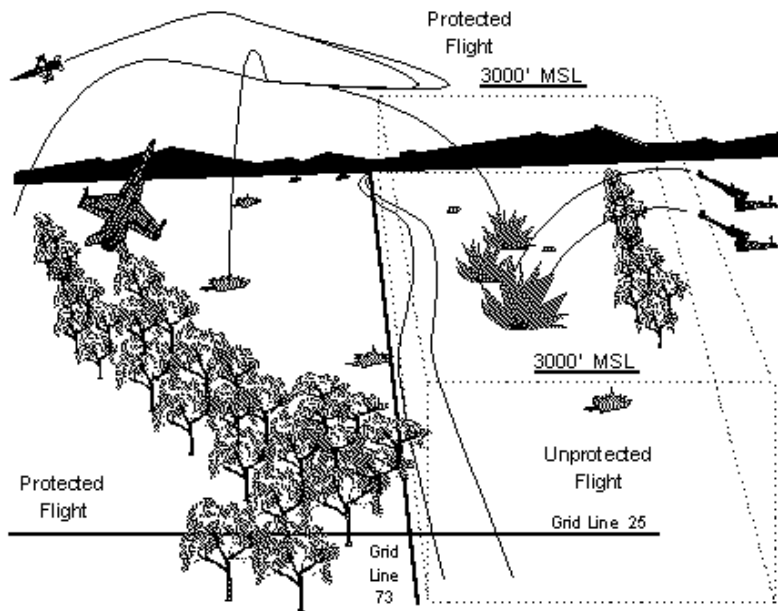

**Figure 3-7. Artillery-Close Air Support Aircraft Altitude Separation.**

- **Time Separation.** Time separation requires the most detailed coordination, and it may be required when aircraft must fly near indirect fire trajectories or ordnance effects. The timing of surface fires must be coordinated with aircraft routing. This ensures that even though aircraft and surface fires may occupy the same space, they do not do so at the same time. All timing for surface fires will be based on the specific aircraft event time (TOT/TTT). This technique

is appropriate when aircraft and firing units engage the same or nearby targets. The weapon's fragmentation envelope and the likelihood of secondary explosions need to be considered when deconflicting aircraft and surface fires. Figures 3-9a, b, and c (pages 3-39 through 3-41) illustrate time separation. Figure 3-10 (page 3-42) summarizes appropriate separation techniques for typical CAS scenarios.

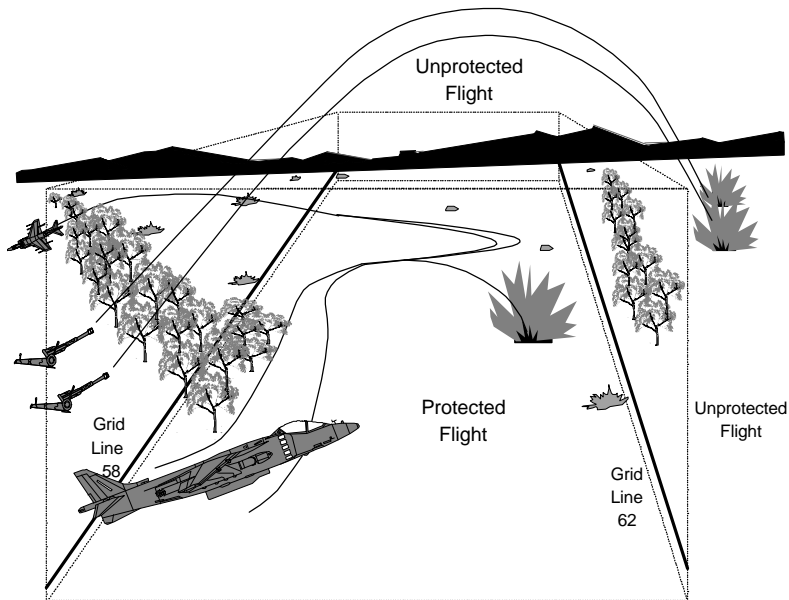

**Figure 3-8. Artillery-Close Air Support Aircraft Altitude and Lateral Time Separation.**

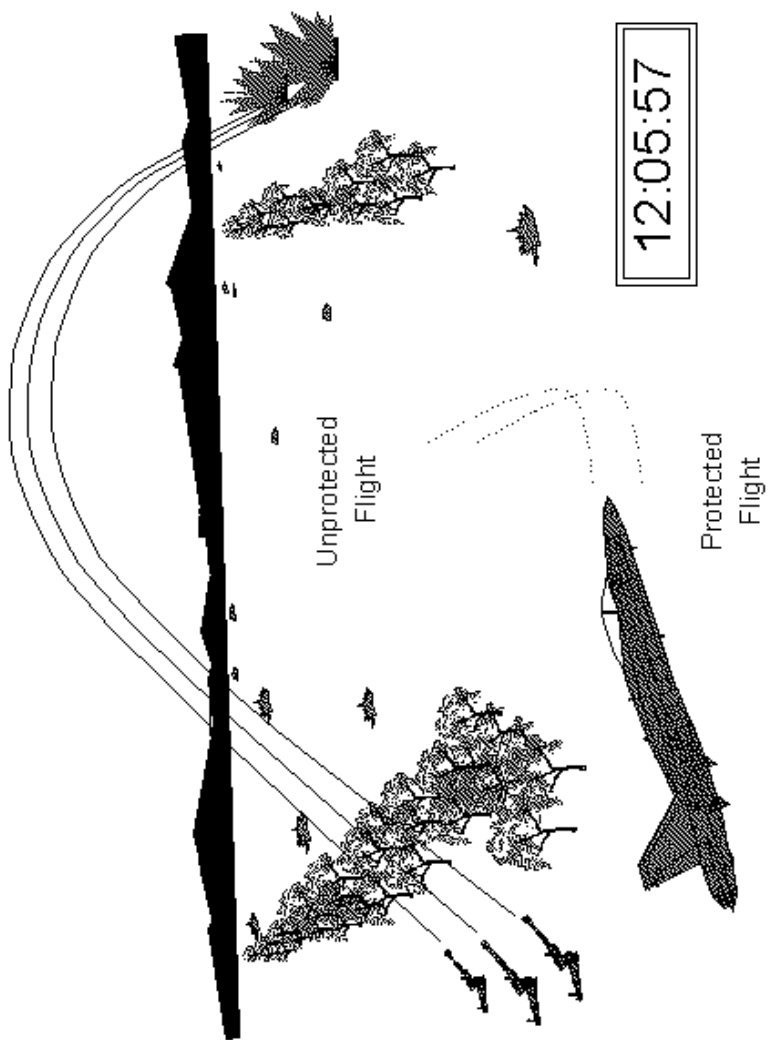

**Figure 3-9a. Artillery-Close Air Support Aircraft Time Separation.**

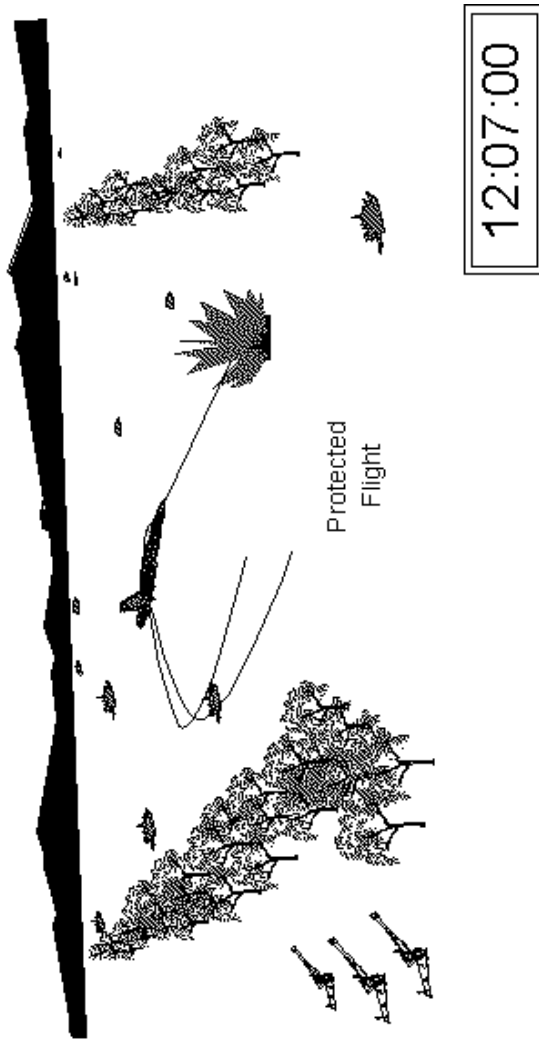

**Figure 3-9b. Artillery-Close Air Support Aircraft Time Separation.**

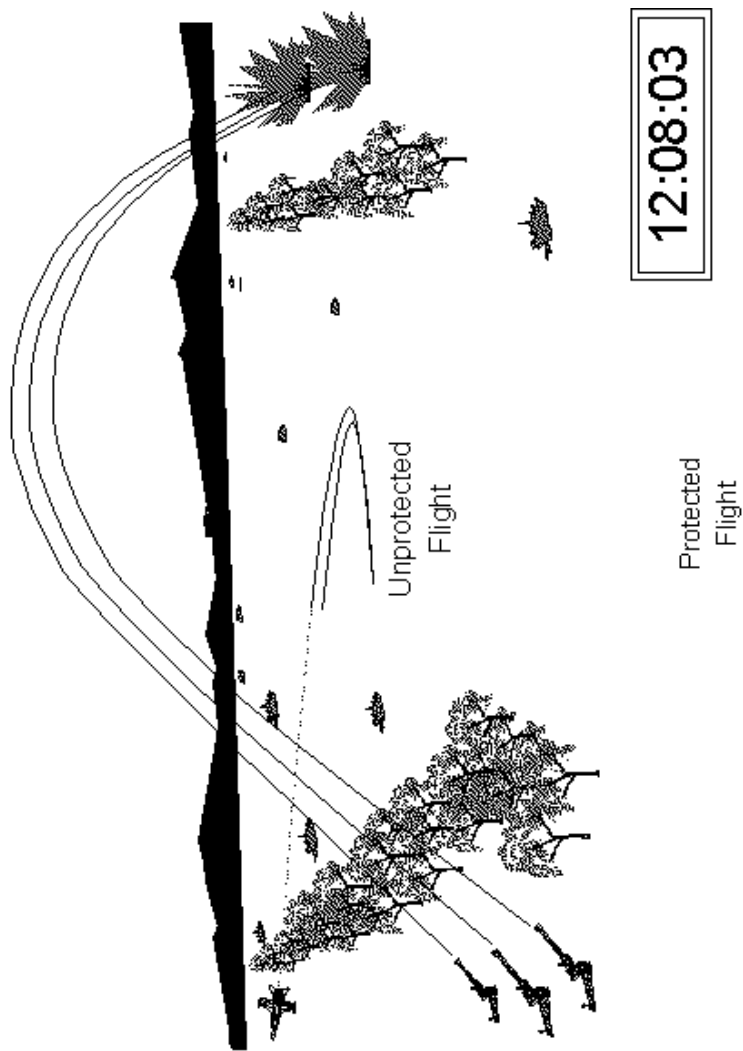

**Figure 3-9c. Artillery-Close Air Support Aircraft Time Separation.**

	CAS Target Same as/ Near Surface Target	CAS Target Distance From Surface Target	CAS Target Along Gun- Target Line
High/Medium Altitude Attack	Altitude Separation	Altitude Separation	Altitude and/or Lateral Separation
Low/Very Low Altitude Attack	Time Separation	Altitude or Lateral Separation	Altitude and/or Lateral Separation

**Figure 3-10. Separation Techniques.**

### COORDINATED OPERATIONS

A joint air attack team (JAAT) operation is a coordinated attack against one target by attack helicopter units and fixed-wing attack aircraft, normally supported by artillery or NSFS. Terminal controllers may perform duties from airborne positions. JAAT planning considerations and employment methods are discussed in MCRP 3-23A, *The Joint Air Attack Team*.



## SECTION III. REQUESTING AND TASKING

### MAGTF COMMANDER'S GUIDANCE

The MAGTF commander provides guidance on the use of aviation to accomplish the mission. The MAGTF commander's guidance relating to aviation tasks will focus the efforts of subordinate commanders and staffs. The amount of air support that will be dedicated to CAS is decided by the MAGTF commander in the air apportionment decision. The MAGTF commander's air apportionment decision is normally based on the recommendation of the ACE commander. As part of the air apportionment decision, the MAGTF commander may identify CAS priorities by geographic area or by percentage. The translation of the apportionment decision into total numbers of sorties by aircraft type is the allocation process and is the responsibility of the ACE commander. The ACE commander considers the JTARs submitted, then estimates the number of sorties required to attack each CAS target. The ACE allots sorties for CAS based on the support required by the main effort, priorities of fire, and requests submitted by other units.

### CLOSE AIR SUPPORT REQUESTS

As the requesting commander plans and conducts operations, situations are identified where CAS can be employed to enhance mission accomplishment. The requesting commander submits either pre-planned or immediate CAS requests. Once CAS is approved, it will be coordinated and integrated into the scheme of maneuver and fire support plan of the requesting unit.

## Preplanned Requests

- **Process.** Commanders normally request CAS to augment organic supporting fires. CAS requirements identified early enough to be included in the ATO or mission order are forwarded as preplanned requests. Some preplanned requests may not include detailed target information or timing information because of the longer lead time involved. Once determined by the requesting unit, information such as potential targets, desired effects, timing, and priority are submitted to prepare the ATO. Air officers and operations officers at all echelons must ensure that necessary information is forwarded through the FSCC as soon as it is made available by their respective echelon's planners and commanders. The important consideration in preplanning CAS is for requesting forces to forward their requests early—as soon as they anticipate the need for CAS—and then regularly update and refine their requests as the support time approaches.
- **Procedures.** Units requesting preplanned CAS submit JTARs through their fire support coordination agencies (FFCCs, FSCCs, or rear area operation centers (RAOCs)). Commanders, AOs, and FSCs at each echelon evaluate and consolidate requests, and coordinate requirements (such as airspace, fires, and intelligence). If the request is approved, a priority and precedence is assigned. The FSC then forwards approved requests to the next higher echelon. If a request is disapproved at some level, the request is returned to the originator with an explanation or a substituted fire support asset. The senior fire support coordination agency in the force approves and prioritizes requests. The prioritized requests are then sent to the MAGTF commander for approval. After approval, these consolidated requests become the commander's request for CAS. The senior fire support coordination agency sends the requests to the Marine TACC for planning and execution. The Marine TACC

publishes the daily ATO, which includes approved CAS missions. The Marine TACC distributes the ATO to other MACCS agencies and the MAGTF. (See figure 3-11.) In joint operations, the JFACC publishes and distributes the ATO. The TACC prepares the Marine forces' portion and forwards it to the JFACC to be merged with the ATO.

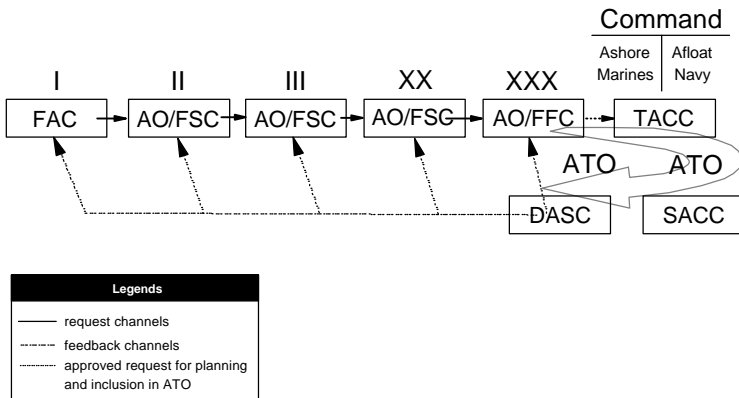

**Figure 3-11. Preplanned Close Air Support Request Channels.**

**Note:** Before commencing operations, MAGTFs should develop

numbers are assigned to subordinate units. The use of predetermined numbers allows requesting units to follow their request from initiation to execution. The request number stays with the request as it is processed through the FSCCs to the TACC. The published ATO includes the request number. Once the supported unit contacts the DASC, the DASC will contact the aircraft and provide routing and other required information.

- **Categories.** Preplanned requests are categorized as either scheduled or on call.
  - **Scheduled Requests.** Scheduled requests require the requesting unit to identify the target and the desired TOT well in advance. The TACC assigns aircraft to meet the scheduled TOT. Scheduled requests offer greater opportunity for effective coordination and provide a higher likelihood that the aircraft will have the proper weapons load for the assigned targets. Scheduled air support requires the requesting commander to identify a specific target and time for the attack beforehand, so that after launch only minimum communications will be necessary for final coordination. However, this specification is often difficult on a fluid battlefield.
  - **On-Call Requests.** On-call requests identify an anticipated requirement for CAS to be available during a period of time, but the exact time and place is coordinated as the battle develops. On-call CAS allows the requesting commander to indicate a time frame, probable target type, and place where the need for CAS is most likely. On-call aircraft are configured with the proper ordnance for anticipated targets, and normally maintain an alert status. Requesting units must be specific as to the location and the duration of the on-call mission. If aircraft are to operate from a forward location, consideration should be given to providing security for the aircraft and allowing for communications with the DASC. On-call requests can indicate the responsiveness necessary by specifying either ground or airborne alert. The TACC then places aircraft on alert in the requested manner for the period specified on the JTAR.

### **Immediate Requests**

- **Process.** Immediate requests arise from situations that develop once the battle is joined with the enemy. Requesting commanders use immediate CAS to exploit opportunities or protect the force. Because immediate requests respond to developments on a dynamic battlefield, they cannot be identified early enough to allow detailed coordination and planning. This may preclude the optimum ordnance load for the particular targets to be attacked. If CAS aircraft are unavailable, the DASC may request the TACC to divert lower priority missions to fill CAS requirements. When diverting aircraft from preplanned CAS missions, it should be realized that those units that have requested preplanned CAS lose the same amount of firepower gained by the immediate requester, if the immediate request is approved. The mission and commander's intent may necessitate the requirement to divert CAS sorties and forgo preplanned missions to meet certain immediate requests.
- **Procedures.** Requests are broadcast directly from the TACP to the DASC using the TAR net. The AOs in each FSCC monitor the TAR net. The DASC processes requests for immediate missions and coordinates with the senior FSCC. Each FSCC will either approve or deny the request based on the commander's intent and after considering whether organic assets are available, appropriate, or sufficient to fulfill the request. Two options are available for subordinate FSCCs to signify approval of requests. Subordinate FSCCs may provide positive verbal approval of each request or may use silence as the consent procedure. If coordination is required for approval, the FSCCs will coordinate at the lowest possible level. If a request is disapproved at some level, the request is returned to the originator with an explanation or a substituted fire support asset. The DASC assigns aircraft according to the type of mission and the terminal control agency's capabilities. For ground alert aircraft, the TACC may retain launch authority or delegate it to the DASC. If the DASC

has launch authority, it launches the aircraft and directs aircrews until they contact the terminal control agency. If the DASC does not have launch authority, it contacts the TACC to launch the aircraft. (See figure 3-12.)

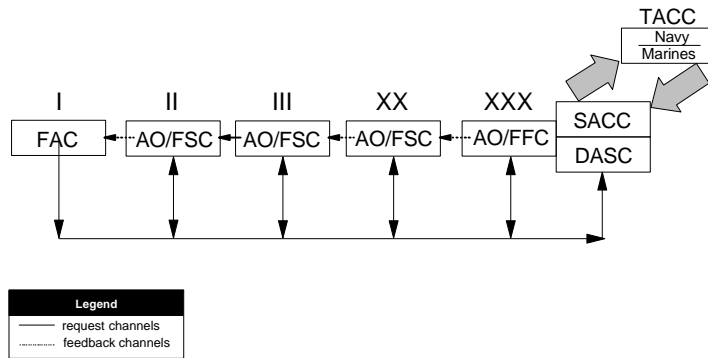

**Figure 3-12. Immediate Close Air Support Request Channels.**

### CLOSE AIR SUPPORT REQUESTS AFLOAT

The following paragraphs address requesting CAS while the Navy TACC controls air support and the SACC has responsibility for coordination.

- **Preplanned Requests.** Units requesting preplanned CAS proceed through the chain of command to the landing force AO. At lower echelons, unit AOs combine and integrate requests with those for NSFS and artillery to reduce duplication and coordinate the fire support effort. The landing force operations officer

examines the combined and coordinated fire plan to confirm that it supports projected operations. After approval by the landing force operations officer, the landing force AO submits these documents to the Navy TACC for approval and coordination with other projected air operations within the AOA. If CAS requirements exceed available assets, the commander, landing force (CLF), recommends priorities for the requests.

- **Immediate Requests.** Units requesting immediate CAS send requests to the ASCS on the TAR net. The air support controller receives, processes, and records these requests. The air support controller coordinates these requests with other members of the SACC. The air support controller informs the requesting unit of request approval and approximate time of execution.

### **JOINT CLOSE AIR SUPPORT REQUEST PROCEDURES**

Units requesting preplanned CAS submit JTARs to their normal fire support coordination agencies. If approved, the requests are evaluated, coordinated, consolidated, and forwarded through component communications nets, with an assigned priority and precedence. If a request is disapproved at some level, the request is returned to the originator with an explanation or a substituted fire support asset. In the Marine Corps component, for example, the FSCC/FFCC of the highest maneuver echelon in the force prioritizes the requests and submits them to the MAGTF commander for approval. After approval, these consolidated requests become the MAGTF commander's requirement for CAS. If the total of all CAS requests exceeds the MAGTF's organic capability, those requests that cannot be met are forwarded to the JAOC via the air support request (AIRSUPREQ) message.

- At the JAOC, the JFACC/JFC staff reviews the requests, matches them in priority order against the JFC's air apportionment decision, and fills those requests with the sorties available according to the air apportionment guidance. The MAGTF is then notified of approval/disapproval via the sortie allotment (SORTIEALOT) message.
- If requests exceed the joint air apportionment for CAS, the JFACC/JFC staff must ask the JFC to modify the CAS air apportionment, request components to produce more joint CAS sorties, or deny the requests exceeding the joint air apportionment for CAS.
- During the execution phase of the joint ATO, the JFACC/JFC staff may need to redirect joint air missions to meet immediate requests for high priority CAS. The JFACC/JFC staff may also seek additional support from other components to meet the immediate request.
- Immediate requests are forwarded to the appropriate command post by the most rapid means available. Requests are broadcast directly from the TACP to the air support operations center by using the applicable component communications nets. The AO at each intermediate headquarters monitors the request and informs the operations officer and FSC. Based on the commander's intent and after considering whether organic assets are available, appropriate, or sufficient to fulfill the request, they approve or deny the request. Either positive approval or silence by intermediate headquarters, whichever is in effect, will indicate approval. See Joint Pub 3-56.1 and Joint Pub 3-09.3, for an expanded discussion.

### **REQUEST FORMAT**



Units will use the JTAR voice format when requesting CAS. See Appendix D, Joint Tactical Airstrike Request Form, for an illustration and the complete instructions.

### **MISSION DATA**

For preplanned requests, mission information is relayed through GCE communications channels, normally over the TAR net. Data may be included in the joint ATO, mission order, or fire support plan. For approved immediate requests, mission data is relayed through the same air request net as that used by the unit requesting the immediate mission. Mission data is passed using the JTAR section 3 format to the requesting unit. As preplanned requests are submitted and refined, as much information as possible concerning the supported unit commander's intent, scheme of maneuver, control measures, and fire support plan should be included. At a minimum, mission data will include mission number, call sign, number and type of aircraft, ordnance, estimated TOT/time on station (TOS), CP, initial contact (whom the aircrew contacts first), and call sign and frequency of final control agency.

## **SECTION IV. NIGHT/ADVERSE WEATHER CLOSE AIR SUPPORT PLANNING**

The execution of night CAS is one of the most difficult missions on the battlefield. Ground forces, both friendly and enemy, conduct operations around the clock. Therefore, the requirement exists to provide CAS at night, during periods of limited visibility, or under adverse weather conditions. Successful night and adverse weather CAS demands rigorous training and detailed mission planning, as well as solid communications and procedural discipline. Aircraft and aircrews conducting night CAS employ modern NVDs, IR pointers, laser systems, battlefield illumination, and standard procedures.

### **BASIC CONSIDERATIONS**

#### **Advantages**

The most important advantage of night and adverse weather CAS is the limitation it imposes on enemy optically-directed antiaircraft artillery and optical-/IR-guided SAMs. This advantage is greatest if the enemy air defense operators do not possess NVDs. Selectively placed airborne and ground illumination may further degrade enemy night vision capabilities while preserving or enhancing those of friendly forces. As an example, overt airborne illumination flares, selectively placed at a distance well behind and above friendly positions (so as not to silhouette friendly positions), could be employed to “degain” enemy NVDs, to improve insufficient light conditions, and to counter enemy IR-guided SAMs. Radar-directed threat systems may remain as lethal at night as in daylight, but gun muzzle

flashes, tracers, and missile/rocket motors are generally easier to see and react to at night.

### **Disadvantages**

Darkness and weather can impose several limitations on CAS employment. During periods of low illumination and reduced visibility, both CAS aircrews and ground forces may have difficulty pinpointing targets and accurately locating enemy or friendly forces. Night and adverse weather CAS missions may also require greater TOS. Thus, fuel capacity and combat radius may be important considerations when tasking aircraft for night CAS. Twilight and overcast conditions may also highlight aircraft to enemy ground forces. If planners have the option, dawn and dusk missions should be avoided in favor of missions flown in total darkness.

### **Friendly Force Location and Identification**

Perhaps the single most important task in conducting CAS is correctly locating and identifying friendly ground forces in close proximity to the intended target. The challenges of identifying friendly and enemy locations, acquiring targets, and maintaining situational awareness become acute at night or in an adverse weather environment. The training, equipping, planning, tasking, and execution processes must recognize these challenges and establish proper CID procedures.

## **AIRCRAFT MUNITIONS AND EQUIPMENT SELECTION**

CAS planners should select those combinations of munitions and aircraft that offer the greatest accuracy, firepower, and flexibility.

When possible, NVD-equipped aircraft that are compatible with laser or IR marking/designation systems and munitions should be used. (See Appendix C.)

- **Precision-Guided Munitions (PGMs).** PGMs are the most accurate munitions for day or night CAS. PGMs span the entire spectrum of delivery means, including fixed- and rotary-wing aircraft, artillery, and naval guns. PGMs include laser-guided, IR-guided, and radar-homing weapons. Hazards associated with PGMs relate to the unlikely probability of missile malfunction, which accounts for the large surface danger zone for this type of ordnance. Overall, the circular error probable (CEP) for PGMs is much smaller than for general-purpose or cluster bomb munitions. Some PGMs, such as the laser Maverick, have a safing feature in case the missile's guiding laser energy is lost.
- **Equipment Selection.** Systems to identify and mark friendly positions or mark/designate targets are important (e.g., IR pointers, IR tape, GPS, and laser target designators (LTDs)). When possible, terminal controllers, FAC(A)s, and CAS aircraft should be equipped with such systems, and the ground force systems should be compatible with those on the CAS aircraft.
- **Equipment Compatibility.** Figure 3-13 compares laser equipment compatibility to other systems relative to the operating areas of the electromagnetic spectrum. As illustrated, compatibility exists only between LTDs and laser spot trackers (LSTs). All coded LTDs can work with all coded laser acquisition/spot trackers and coded laser-guided weapons (LGWs). Likewise, IR pointers and night vision goggles (NVGs) are compatible only with each other. IR pointers cannot designate for LSTs, and NVGs cannot see targets designated by LTDs. Forward-looking infrared (FLIR) systems are not compatible with either laser or IR equipment.

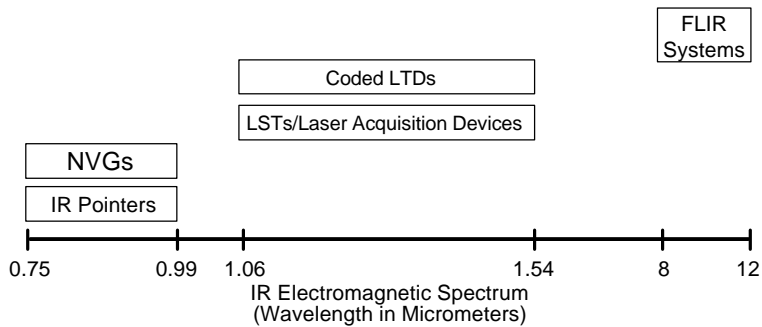

**Figure 3-13. Laser Equipment Compatibility.**

### **VISUAL EMPLOYMENT**

Visual deliveries during night or adverse weather are difficult, but are still a viable option. Artificial illumination may be used to enhance target acquisition. The target may be illuminated or marked by the FAC(A), artillery/mortars, small arms, or by a dedicated flare ship. Airborne delivered marks/illumination may be provided by forward firing rockets or by using parachute flares. Coordination and approval for illumination will be made before entering the target area. Artillery-, mortar-, and airborne-delivered flares that burn on the ground are available as target spotting rounds. After the target area is illuminated, specific targets may be marked by white/red phosphorous rockets, mortars, or artillery to aid the aircrew in acquiring, identifying, and attacking these targets.

### **SYSTEM-AIDED EMPLOYMENT**

System-aided target acquisition and weapons delivery methods are relied on more heavily during the night and adverse weather. System-aided employment options can be used independently, but combining the systems increases the probability of mission success. These include laser, electro-optical (EO)/IR systems, radar, GPS, or a combination of systems.

- **Laser.** Night procedures for target identification and designation by laser are the same as those used during daytime operations. However, adverse weather may limit the use of lasers. Cloud cover and precipitation, as well as battlefield conditions (smoke, dust, haze, specular reflectors, and other obscurants), can seriously degrade laser effectiveness. Using the EO tactical decision aid (EOTDA) will help planners to determine the effects of weather on sensors and weapons. See Joint Pub 3-09.1, *Joint Laser Designation Procedures*, for further information.
- **EO/IR Systems.** The capabilities of low-light-level television (LLLTV) and FLIR systems are the same for day as they are for night. Cloud cover, humidity, precipitation, thermal crossover, and battlefield conditions (smoke, dust, haze, and other obscurants) may degrade the effectiveness of FLIR and LLLTV.
- **Radar.** Although not preferred, radar deliveries are an option in certain instances. During severe weather or when the target cannot be marked, this type of weapons delivery may be the only option available. Appendix C lists the aircraft that are capable of radar-directed bombing. To perform a radar delivery, the target or offset aim point(s) must be radar significant.
- **GPS.** Weapons can be delivered at night or through bad weather at specific coordinates by GPS-equipped aircraft. When supplied with GPS coordinates by terminal controllers, computed deliveries can be extremely accurate.

- **Combined System Employment.** The use of a combination of complementary systems can greatly aid and refine target acquisition. A GPS-derived target grid and laser spot, combined with an aircraft equipped with an LST and the ability to input the target grid into its fire control system, can provide very accurate target location information.

## **NIGHT VISION DEVICE EMPLOYMENT**

NVDs include NVGs and IR systems. NVGs and IR systems (e.g., FLIR systems) and low-altitude navigation and targeting IR for night (LANTIRN) may provide the primary navigation, targeting, and terrain avoidance reference for the night CAS mission. NVGs and IR systems operate on the same basic principle by using the red and near-IR regions of the light spectrum to produce a visible image. NVGs feature image intensifier tubes that produce a bright monochromatic (green) image in light conditions that are too low for normal unassisted vision. This image is based on the relationship between the amount of light present, referred to as illuminance, and the amount of light that is reflected from objects in the scene, referred to as luminance or brightness. IR systems use the far-IR wavelengths to create an image that is based on object temperature and emissivity relative to the surroundings.

### **Advantages**

NVDs are used as an additional sensor with existing systems; this allows all NVD-equipped ground and air units to maintain enhanced situational awareness and crew confidence levels. NVDs, used

under the proper weather and illumination conditions, provide the ability to “see in the dark” and to allow target detection, recognition, and attack at night. This enhances the elements of surprise and survivability in all threat environments. Ground forces (especially special operations forces (SOF)) benefit from the smaller, lightweight NVD equipment by providing pre-H-hour and H-hour methods of attacking targets, along with CAS target marking. NVDs and associated IR devices can play a key role in minimizing the risk of fratricide when employed to enhance situational awareness of friendly and enemy positions.

### **Disadvantages**

Reduced illumination levels caused by the moon phase, weather, or battlefield obscurants may degrade the ability to effectively employ NVDs without artificial illumination. Under certain conditions, reduced illumination levels may be mitigated by properly placed artificial illumination sources. Used improperly, the limited field of view of NVGs can lead to loss of situational awareness, given the increased task workload demanded for CAS missions. Extensive training for all units is required to ensure mission success. Additional disadvantages may exist if the enemy possesses NVDs, thus limiting or even negating friendly use. Decoy and deceptive lighting can easily be employed, but this can cause confusion for the aircrews if the terminal controller cannot communicate the correct lighting marks to CAS aircraft.

### **Planning Considerations**

NVDs can significantly increase the capability of ground and airborne units to detect ground targets in a night CAS environment. Certain natural conditions determine the aircrew’s ability to acquire



the target visually. NVDs are particularly useful for increasing situational awareness and in some instances can be used for target acquisition.

- **Moon Phase, Elevation, and Azimuth.** The moon phase, or percent of moon disk as a fraction of the full moon, is the most significant night illumination factor. A full moon provides considerable lighting for NVDs. The elevation of the moon and its relative azimuth in the night sky also play a significant role. Low moon angles can create significant shadowing, and moon positions that lay behind a target and are reciprocal to final attack headings may degrade NVD operations. Moon elevations of 20 degrees or more and moon offsets of 30 degrees or more may be required to prevent NVD degradation.
- **Mean Starlight.** Light from nonmoon celestial sources provides limited illumination and on relatively clear nights will suffice for general situational awareness. Depending on the target size and orientation, there may not be enough light under mean starlight conditions for target acquisition.
- **Weather Conditions.** Cloud cover, cloud base height, and reduced atmospheric visibility significantly degrade any benefits provided by moon and mean starlight illumination. The same conditions may also degrade IR target sources.
- **Cultural Lighting.** Light sources (e.g., city lights, highway lighting, and other sources, such as fires) provide lighting that can help with general illumination. Extremely bright light sources will wash out the NVD field of view when viewed directly.

## TARGET IDENTIFIERS

IR devices and illumination can be used to aid in specific target location and acquisition at night. Both can significantly increase the effectiveness of CAS accuracy in the night environment. Additionally, IR devices can provide a covert means to mark night CAS targets. IR devices can also be used by FAC(A)s to guide NVD-equipped CAS aircraft to targets.

- **IR pointers.** IR pointers are low-power, uncoded designators used for target cueing and identification in conjunction with NVDs. They do not provide terminal weapons guidance and they are not compatible with LSTs. These systems operate in the lower portion of the IR spectrum and are compatible only with NVDs. Aircraft and ground personnel operating with NVDs use IR pointers to visually acquire targets. IR pointers or IR illuminators can aid in target acquisition by highlighting the target with IR light. The IR pointer should be offset from the aircraft run-in heading to facilitate aircrew acquisition. Moving the pointer beam will also help in acquisition of the beam, and once acquired, the FAC can guide the pilot's eyes and sensors onto the intended target. Two-way communication between the FAC and aircrew during this process is essential.
- **IR Strobe Lights.** IR strobe lights can be used by FACs and by properly equipped aircraft to provide covert position identification to NVD-equipped personnel. This provides positive location of the FAC and/or friendly forces to CAS aircrews.
- **IR Flares.** IR flares can provide general target area illumination that is visible only to NVD-equipped personnel and can be useful from several miles away.

- **Airborne Illumination.** Many aircraft that are capable of providing CAS can deploy illumination flares. The aircraft capabilities tables in Appendix C list flare-capable aircraft and the types of flares/illuminating devices each can carry.
- **Surface-Delivered Illumination.** Illumination can be delivered by ground units, artillery, mortars, and naval gunfire to illuminate the target area, to mark the target, or to identify friendly positions.
- **Laser Designators (Ground/Airborne).** Coded LTDs are ground and airborne systems that are well suited for night target marking. LTDs provide terminal weapons guidance for LGWs, and they designate targets for coded LSTs. Coded LTDs emit laser energy at a distinct pulse repetition frequency (PRF), and they require input of a particular laser code for operation. Codes are assigned to LGWs and directly relate to the PRF that harmonizes the designator and seeker interface. The aircraft capabilities tables in Appendix C list aircraft equipped with LTDs.
- **Radar.** Aircraft can use radar-significant terrain points or radar reflectors to enhance bombing. The radar beacon, employed by terminal controllers, is a portable manpack transponder that emits an electronic pulse on compatible radar-equipped aircraft. Appendix C lists radar beacon-compatible aircraft.
- **Enemy Ground Fire.** Enemy ground fire, tracer rounds, AAA, and SAM firings can disclose targets.
- **Friendly Small Arms.** Tracers that impact on or near the target are excellent marks. However, tracers may also help confirm friendly positions.

## **Chapter 4**

# **Execution**

CAS provides the MAGTF with flexible, responsive fire support and is able to accurately employ a wide range of weapons. CAS can surprise the enemy and create opportunities for the maneuver or advancement of ground forces. CAS can protect flanks, blunt enemy offensives, and protect forces during a retrograde. More importantly, CAS may at times be the only supporting arm available to the commander. The following should be considered during CAS execution.

### **SECTION I. BASIC CONSIDERATIONS**

#### **SYNCHRONIZED TIMING**

A common reference time is essential for accomplishing the high degree of coordination necessary for effective CAS. All participants—aircrews, terminal controllers, the TACC, the SACC, the DASC, and the FSCC—use the same timing method. There are two methods of timing: TOT and TTT. A synchronized clock using TOT is the standard method of timing aircraft attacks. The synchronized clock also solves the problem of coordinating a TOT “Hack” over several different radio nets. The ATO and OPORD should specify the clock time (local or Zulu) and should also identify the unit or agency responsible for coordinating the synchronized time. The synchronized clock is normally based on GPS or U.S. Naval Observatory time. Aircrews can update the clock on check-in with

air control and fire support coordination agencies. Aircrews may request a TTT if preferred, or if they are unable to use a TOT.

**Note:** Zulu time is available from the U.S. Naval Observatory master clock as an automated, continuous broadcast on the following high frequency wavelengths: 5.000, 10.000, 15.000, 20.000, and 25.000 MHz. It is also available by telephone on DSN 762-1401 or (202) 762-1401. Alternatively, GPS satellites provide a standard time reference for using GPS equipment.

## **SECURITY**

MAGTF commanders prescribe standardized cryptologic and authentication procedures in the OPORD and distribute updated instructions in the ATO, in special instructions, and in fragmentary orders (FRAGOs) to the MAGTF OPORD.

## **CHECK-IN**

Check-in procedures are essential for establishing the required flow of information between CAS aircrews and control agencies. Control agencies should update all en route CAS aircrews on the current intelligence situation in the target area and on any changes to pre-planned missions. The CAS check-in briefing format found in figure 4-1 is used on check-in with terminal controllers.

## **CLOSE AIR SUPPORT BRIEFING FORM**

The CAS brief (Figure 4-2, page 4-4), also known as the “nine-line brief,” is the standard brief used for all aircraft conducting CAS. The brief is used for all threat conditions and does not dictate the

## Close Air Support 4 - 3

CAS aircrew's tactics. The mission brief follows the numbered sequence (1-9) of the CAS briefing form. Use of a standardized briefing sequence improves mission direction and control by allowing terminal controllers to pass information rapidly and succinctly.

(Aircraft Transmits to Controller)

Aircraft: \_\_\_\_\_, this is \_\_\_\_\_  
(controller call sign) (aircraft call sign)

1. Identification/Mission Number: \_\_\_\_\_

Note: Authentication and an appropriate response are suggested here.  
The brief may be abbreviated for brevity or security ("as fragged" or "with exception").

2. Number and Type of Aircraft: \_\_\_\_\_

3. Position and Altitude: \_\_\_\_\_

4. Ordnance: \_\_\_\_\_

5. Time on Station: \_\_\_\_\_

6. Abort Code: \_\_\_\_\_  
(if applicable)

**Figure 4-1. Close Air Support Check-In Brief.**

This mission information and sequence may be modified to fit the tactical situation. The CAS briefing helps aircrews to determine the information required to perform the mission. When the terminal controller needs a confirmation that the aircrew has correctly received critical items of the brief, the terminal controller will request a "read back." When a "read back" is requested, the aircrew will repeat back items 1, 6, 8, and any restrictions. North Atlantic Treaty

Omit data not required; do not transmit line numbers. Units of measure are standard unless otherwise specified.

\* Denotes minimum essential information required in a limited-communication environment. Bold denotes readback items when requested.

Terminal controller: \_\_\_\_\_, this is \_\_\_\_\_  
(aircraft call sign) (terminal controller)

\*1. IP/BP: \_\_\_\_\_

\*2. Heading: \_\_\_\_\_ Offset \_\_\_\_\_ (left/right)

\*3. Distance: \_\_\_\_\_

\*4. Target elevation: \_\_\_\_\_ (in feet above MSL)

\*5. Target description: \_\_\_\_\_

\*6. Target location: \_\_\_\_\_  
(latitude/longitude, grid coordinates, offsets or visual)

7. Type mark: \_\_\_\_\_ Code: \_\_\_\_\_  
(W/P Laser/IR/beacon) (actual code)

Laser-to-target line: \_\_\_\_\_ degrees

\*8. Location of friendlies: \_\_\_\_\_  
 Position marked by: \_\_\_\_\_

9. Egress \_\_\_\_\_

.....

Remarks (as appropriate): \_\_\_\_\_  
(Threats, hazards, weather, restrictions, ordnance delivery, attack heading, danger close, or SEAD)

Time on target: TOT \_\_\_\_\_

— or —

Time to target: standby \_\_\_\_\_, plus \_\_\_\_\_ ... Hack

**Figure 4-2. Close Air Support Briefing Form (9-Line).**

Organization (NATO) check-in and CAS briefing formats differ slightly from the U.S. joint format. See Appendix G for NATO CAS briefing formats. The following paragraphs detail the line-by-line elements of the CAS brief:

- **IP/BP.** The IP is the starting point for the run-in to the target. For rotary-wing aircraft, the BP is where attacks on the target are commenced.
- **Heading.** The heading is given in degrees magnetic from the IP to the target or from the center of the BP to the target. Terminal controllers give an offset (offset left/right) if a restriction exists. The offset is the side of the IP-to-target line on which aircrews can maneuver for the attack.
- **Distance.** The distance is given from the IP/BP to the target. For fixed-wing aircraft, the distance is given in NM and should be accurate to a tenth of an NM. For attack helicopters, the distance is given in meters from the center of the BP and is accurate to the nearest 5 m.
- **Target Elevation.** The target elevation is given in feet above MSL.
- **Target Description.** The target description should be specific enough for the aircrew to recognize the target. The target should be described accurately and concisely.
- **Target Location.** The terminal controller can give the target location in several ways (e.g., grid coordinates, latitude and longitude, navigational aid fix, or visual description from a conspicuous reference point). Because of the multiple coordinate systems available for use, the datum that will be used must always be specified in the JTAR. If using grid coordinates, terminal controllers must include the 100,000-m grid identification.



For an area target, give the location of the target's center or location of the greatest concentration. For a linear target, give the location of the ends of the target.

- **Mark Type.** Mark type is the type of mark the terminal controller will use (smoke or laser) and the laser code (code) the terminal controller will use.
- **Friendlylies.** The distance of friendlylies from the target is given in meters and is a cardinal heading from the target (north, south, east, or west). If the friendly position is marked, identify the type of mark.
- **Egress.** These are the instructions the aircrews use to exit the target area. Egress instructions can be given as a cardinal direction or by using control points. The word "egress" is used before delivering the egress instructions.
- **Remarks.** The following information should be included if applicable:
  - Laser-to-target line (in degrees magnetic)
  - Ordnance delivery
  - Threat and location
  - Final attack heading (final attack cone headings)
  - Hazards to aviation
  - ACAs
  - Weather
  - Restrictions

- Additional target information
- SEAD and location
- Laser, illumination, and night vision capability
- Danger close.
- **TOT/TTT.** The terminal controller gives aircrew a TOT or TTT.
  - **TOT.** TOT is the synchronized clock time when ordnance is expected to hit the target. TOT is the timing standard for CAS missions. There is no time “Hack” statement when using TOT.
  - **TTT.** TTT is the time in minutes and seconds, after the time “Hack” statement is delivered, when ordnance is expected to hit the target. The time “Hack” statement indicates the moment when all participants start the timing countdown.

### RISK-ESTIMATE DISTANCE

#### Troops in Contact

Terminal controllers and aircrews must be careful when conducting CAS when friendly troops are in direct contact with enemy forces. The terminal controller should regard friendlies within 1 km as a “troops in contact” situation and so advise the supported commander. However, friendlies outside 1 km may still be subject to weapons effects. Terminal controllers and aircrews must carefully weigh the choice of munitions and delivery profile against the risk of fratricide.

## Danger Close

Ordnance delivery inside the 0.1% probability of incapacitation (PI) distance will be considered “danger close.” The supported commander must accept responsibility for the risk to friendly forces when targets are inside the 0.1% PI distance. Risk acceptance is confirmed when the supported commander passes his initials to the attacking CAS aircraft, signifying that he accepts the risk inherent in ordnance delivery inside the 0.1% PI distance. Risk-estimate distances allow the supported commander to estimate the danger to friendly troops from the CAS attack. Risk-estimate distances are listed in Appendix F. When ordnance is a factor in the safety of friendly troops, the aircraft’s axis of attack should be parallel to the friendly force’s axis or orientation. This will preclude long and/or short deliveries from being a factor to friendlies. Forward-firing ordnance such as 20-mm, 25-mm, or 30-mm cannon fire; Maverick missiles; or rockets should be expended with the ricochet fan oriented away from friendly locations.

## TARGET MARKING

Target marking aids aircrews in locating the target that the supported unit desires to be attacked. Terminal controllers should provide a target mark whenever possible. To be effective, the mark must be timely and accurate. Target marks may be confused with other fires on the battlefield, suppression rounds, detonations, and marks on other targets. Although a mark is not mandatory, it assists in CAS accuracy, enhances situational awareness, and reduces the possibility of fratricide.

- **Mark Timing.** Laser marks are initiated by a 10-second warning and “Laser On” command from the CAS aircrew. IR pointers and indirect fire munitions marks (except illumination) should

appear/impact 30 to 45 seconds before the scheduled CAS aircraft ordnance impact. Illumination rounds should impact in sufficient time before target engagement to allow the illumination flare to become fully visible. In high winds, the target mark should arrive closer to ordnance impact time (and upwind if possible) as the effects of the mark (smoke/dust) tend to dissipate rapidly. An exception is timing for standoff or precision guided weapons, which may require the mark up to 60 seconds before air-delivered ordnance impact. When the time of fall or time of flight of the weapon is greater than 15 seconds, the CAS aircrew should request an earlier mark. Delaying the request for a change to the standard mark timing will prevent proper coordination and can cause an aborted mission due to an inaccurate or missing mark.

- **Mark Accuracy.** The visual mark should impact within 300 m of the target to ensure a successful attack. Visual marks that land beyond 300 m from the target may not provide the CAS aircrew with a visual cue that allows attack of the correct target. The most accurate mark is a laser when the FAC or laser designator operator can maintain line of sight with the target. IR and munitions marks should be placed as near the target as possible to help ensure target identification.
- **Laser Marking.** Missions involving LGWs require coordination of laser-compatible designators, ordnance, and attack parameters. For preplanned missions, include the designation code in line 7 of the CAS briefing form. For immediate missions, the requesting unit includes the availability of a laser designator/code. If the aircraft has an LST, the preferred method of marking a target is by laser. The laser ensures the accurate engagement of the target by LGWs and assists the CAS aircrew in more accurately delivering unguided ordnance. If using lasers (ground or airborne) to mark the target, laser designation must be selective and timely because laser devices can overheat and lengthy laser

emissions may compromise friendly positions. For laser marks, the aircrew will normally provide a 10-second warning to activate the mark. See section III of this chapter for more information.

- **IR Marking.** IR pointers and other IR devices can be used by terminal controllers to mark targets at night for aircrews who are using NVDs. Unlike laser designators, these IR devices cannot be used to guide or improve the accuracy of aircraft ordnance. Caution should be used when using IR pointers as they may expose the terminal controller to an enemy with night vision capability. IR marks should be initiated 20 to 30 seconds before the CAS TOT/TTT, or when requested by the aircrew, and continue until the aircrew transmits "Terminate" or the weapon hits the target. See section II of this chapter for more information.
- **Marking by Indirect Fire.** Artillery, naval gunfire, or mortar fires are an effective means of assisting aircrews in visually acquiring the target. Before choosing to mark by artillery, naval gunfire, or mortars, observers should consider the danger of exposing these supporting arms to the enemy's indirect fire acquisition systems and the additional coordination between supporting arms required for this mission. Munitions marking rounds should be delivered as close to CAS targets as possible, with white/red phosphorous marks timed to impact 30 to 45 seconds before the CAS TOT/TTT. Illumination marks should be timed to impact 45 seconds before the CAS TOT/TTT. This lead time ensures that the marking round is in position early enough and remains visible long enough for the terminal controller to provide final control instructions and for the aircrew of the lead aircraft to acquire the target. Indirect fire marking rounds are most effective when delivered within 100 m of the CAS target, but those within 300 m of the CAS target are generally considered effective enough to direct CAS aircraft. If the indirect fire marking round is not timely or accurate, terminal controllers

should be prepared to use a backup marking technique or to rely completely on verbal instructions to identify the target to the CAS aircrews. If the situation requires a precise mark, observers or spotters can adjust marking rounds early to ensure that an accurate mark is delivered to meet the CAS schedule. This may, however, alert the enemy to an imminent attack.

- **Marking by Direct Fire.** Direct-fire weapons can be used to deliver a mark. Although this method may be more accurate and timely than an indirect fire mark, its use may be limited by range and the visibility of the weapon's burst effect on the battlefield.
- **Marking by Aircraft.** Aircraft may be used to deliver a mark. The preferred method is for FAC(A) aircraft to mark with white or red phosphorous, high explosive rockets, illumination, and/or lasers. See Appendix C for a complete listing of aircraft target marking capabilities.
- **Backup Marks.** Whenever a mark is provided, a plan for a backup mark should be considered. For example, artillery may be tasked to deliver the primary mark, while a mortar or aircraft may be assigned responsibility for the backup mark.
- **Additional Marking Techniques**
  - **Voice-Only.** In a medium- or low-threat environment, the terminal controller may "talk the aircrew onto the target" by verbally describing the target to be attacked. The standard brevity terms listed in figure 4-3 are used in these circumstances.

Call	Meaning
Visual	The terminal controller has the attack aircraft in sight, or the attack aircraft has positively identified the terminal controller's or friendly position.
Contact	Attacking aircraft acknowledges sighting of a specified reference point.
Tally	The enemy position/target is in sight.
Note: All terms may be further amplified by including additional words (e.g., "Tally Target").	

**Figure 4-3. Standard Close Air Support Brevity Terms.**

- **Combination.** When necessary, and when conditions permit, terminal controllers can use a combination of verbal and visual marking to aid in orienting CAS aircrews on the target.
- **Marking Friendly Positions.** Friendly forces can mark their own position with NVDs, IR strobes, smoke, signal panels, or a mirror. This achieves the same results as target marking as long as the mark is understood by the CAS aircrews. Marking friendly positions is the least desirable method of providing a target mark and should be used with caution because marking friendly positions can be confusing. This technique should be used only when no other method is available.

## FINAL ATTACK CONTROL

After the aircraft depart the CP or HA, the terminal controller provides target and threat updates to the aircrews. The terminal controller may direct the aircrews to report departing the IP or arrival in the BP. This information may be used to coordinate the CAS

attack with SEAD, marking, or the maneuver of the supported unit. The terminal controller attempts to acquire the CAS aircraft visually and give final corrections to assist in target acquisition by the aircrew. Corrections are given in two parts—direction and distance. Corrections from a visual mark will be passed by using the eight points of the compass and a common distance reference.

- **From Ordnance Impact.** Corrections can be made from the last ordnance to impact the target. (See figure 4-4.)

“Blade 11, this is Tango Four Whiskey, from the mark, northeast—two hundred meters.”

**Figure 4-4. Correction From Ordnance Impact.**

- **From a Reference Point.** Corrections can be made from a recognizable reference point. The terminal controller also selects a ground feature to establish a common distance reference. (See figure 4-5.)

“T-bolt 22, this is Tango Four Whiskey. The tree line runs east to west. From the road intersection east to the bridge is one unit. From the bridge, the target is northeast three units.”

**Figure 4-5. Correction From a Reference Point.**

**Clearance to Drop/Fire**



Responsibility for expenditure of ordnance rests with the ground commander. The terminal controller has the authority to clear aircraft to release weapons after specific or general release approval from the ground commander. Battlefield conditions, aircrew training, ordnance capabilities, and terminal controller experience are factors in the decision to authorize weapons release. The two levels of weapons release authority are positive control and reasonable assurance. A “Cleared Hot” clearance should be given as soon as possible in the delivery sequence after the terminal controller is convinced the attacking aircraft sees the target and will not release on friendly positions. This allows the aircrew to concentrate on the weapons solution and improves delivery accuracy, further reducing the possibility of fratricide.

**Positive Control.** Positive control will be used to the maximum extent possible. The terminal controller or an observer in contact with the terminal controller must be in a position to see the attacking aircraft and target and must receive verbal confirmation that the objective/mark is in sight from the attacking aircrew before issuing the clearance to drop/fire. A positive clearance by the terminal controller (“Cleared Hot”) is *mandatory* before any release of ordnance by the aircrew. The “Cleared Hot” call can be made only after the terminal controller confirms the aircraft is:

- On the proper attack heading
- Wings level
- Pointing at the correct target.

The terminal controller should request the following calls from the aircrew in the remarks portion of the CAS brief: “IP Inbound,” “Popping” or “In,” and “Wings Level.” This will facilitate positive

control and aid the terminal controller in successfully conducting the CAS mission. Aircrew call “In” (commencing an attack run) using the format in figure 4-6. Following the “Wings Level” call, all other CAS aircrews should maintain radio silence, except to make threat calls, and allow the terminal controller to transmit the appropriate control and clearance communications listed in figure 4-7. During peacetime training/exercises, personnel involved in CAS missions follow training range regulations for the release of ordnance. The two methods of exercising positive control are direct and indirect control.

\_\_\_\_\_ (call sign), in from \_\_\_\_\_ (cardinal heading).  
Mark in sight/not in sight (if appropriate).

**Figure 4-6. Attack Aircrew “In” Call Format.**

- **Direct Control.** Direct control will be used whenever possible. It occurs when the terminal controller is able to observe and control the attack. The terminal controller transmits “Cleared Hot” when he sees the aircraft is attacking the correct target. There may be times when the terminal controller may not be able to see the attacking aircraft (because of high altitude, standoff weapons, night, or poor visibility). In these cases, clearance to drop will be given only if the terminal controller can use other means to confirm that the aircraft is attacking the correct target and has friendly positions in sight. These means include, but are not limited to, confirming with a verbal description that the aircraft has friendly positions in sight, the mark in sight, and the target in sight, as appropriate.

Call	Meaning
Continue	Continue the pass. You are not yet cleared to release any ordnance.
Abort (abort code)	Abort the pass. Do not release any ordnance.
Cleared Hot	You are cleared to release ordnance on this pass.
Continue Dry	You are cleared to proceed with the attack run but you may not release any ordnance.
<b>Warning</b>	
The word "Cleared" will be used only when ordnance is actually to be delivered. This will minimize the chances of dropping ordnance on dry passes and further reduce the risk of fratricide.	

**Figure 4-7. Terminal Controller's Calls.**

- **Indirect Control.** Indirect control is not the preferred method of positive control. It is used when the terminal controller cannot observe the attack, but is in contact with someone who can. The terminal controller can issue clearance or abort the attack based on information from the observer. This form of control must be authorized by the ground commander.
- During combat operations, battlefield conditions such as communications jamming or low-altitude flight can prevent receipt of positive clearance to complete the attack. Commanders can establish guidelines that allow CAS aircrews to continue attacks on targets under such unusual circumstances.

### Reasonable Assurance

Reasonable assurance is a circumstance under which the supported ground commander assumes an acceptable level of risk in allowing

aircrews to attack targets by releasing ordnance *without* positive control. Specific employment criteria ensure that the supported ground commander, the terminal controller, and the aircrew are reasonably assured, *during each CAS mission*, that ordnance will not adversely affect friendly forces. Careful consideration must be given to using reasonable assurance in combat operations. Reasonable assurance is not a routine procedure. Reasonable assurance allows the delivery of ordnance without positive verbal clearance if the aircrew is reasonably assured that the proper target will be attacked.

Reasonable assurance is considered when the terminal controller, supported commander, and aircrews are confident the attack will not harm friendly forces. The MAGTF commander establishes the procedures for situations where reasonable assurance may be used. Precise guidelines for the use of reasonable assurance are established and distributed throughout the MAGTF and supporting forces.

### **Reattacks**

Reattacks allow CAS aircraft to expeditiously maneuver, at the aircrew's discretion while in compliance with any restrictions in force, to a wings-level attack position subsequent to a CAS attack. Clearance for immediate reattack is issued by the terminal controller.

Each reattack is a separate evolution from any previous attack, and positive clearance is required each time. Clearance for a reattack does not obviate the need for another sequence of "Wings Level" and "Cleared Hot" calls by the aircrew and terminal controller. Once positioned for the reattack, the aircrew reports "Wings Level." As was required in the initial CAS attack, clearance to drop/fire on a reattack *must* be issued by the terminal controller before ordnance release. Clearance for reattack *is not* an indefinite clearance to

drop/fire. Information regarding targeting (corrections, shift to new target, new restrictions) can be given to the aircrew during maneuvering. Positive confirmation of a subsequent target must be asked of and received from the aircrew if the target has changed.

## **ABORT PROCEDURES**

The terminal controller must direct CAS aircrews to abort if they are not aligned with the correct target, if it appears that friendly troops may be endangered, or for the safety of the CAS aircrew.

### **Abort Code**

The CAS abort procedure uses the “challenge-reply” method to authenticate the abort command. During the CAS check-in briefing, the flight lead gives the terminal controller a two-letter challenge code for use with his flight only. The terminal controller refers to his authentication document, finds the reply, and notes but does not transmit it. The reply “letter” becomes that flight’s abort code. If no abort code was briefed, then the CAS attack is aborted by simply transmitting, “Abort, Abort, Abort.” (See figure 4-8.)

The terminal controller is "DEVILDOG"; the CAS attack flight is "GUNRUNNER 31." GUNRUNNER 31 flight has chosen "BR" (authenticated "D") as its abort code.	
Radio Call	Required Action
(During the CAS check-in briefing):  "DEVILDOG, this is GUN-RUNNER 31, abort code Bravo Romeo."	DEVILDOG notes the correct reply for "BR" is "D".
(The CAS attack is in progress and the FAC calls for an abort):  "GUNRUNNER 31, DEVIL-DOG, Abort Delta, Abort Delta, Abort Delta".	GUNRUNNER 31 is not cleared to release ordnance and discontinues the CAS attack.

**Figure 4-8. Abort Call Example.**

**BATTLE DAMAGE ASSESSMENT**

BDA is used to update the enemy order of battle. Accurate BDA is critical for determining if a target should be reattacked. The BDA should include:

- Information relating the BDA being given to a specific target (e.g., target coordinates, target number, mission number, munitions expended, or target description)
- Time of attack

- Damage actually seen (e.g., secondary explosions or fires, enemy casualties, or number and type of vehicles/structures damaged or destroyed)
- Mission accomplishment. (Were the desired effects achieved?)

### **Terminal Controller Responsibilities**

Whenever possible, the terminal controller provides attack flights with the BDA of their attack as they egress. The terminal controller gives BDA for the flight, not for individual aircraft in the flight. At times, it may not be possible to pass all BDA information. At a minimum, the terminal controller should pass an assessment of mission accomplishment. Additionally, the terminal controller should provide all available BDA information to the DASC or appropriate C2 agency.

### **Aircrew Responsibilities**

CAS aircrews use the MISREP to provide information on mission results (See figure 4-9.) Joint CAS missions use the abbreviated United States message text format (USMTF) in-flight report (INFLTREP). For more information on in-flight reporting, see Joint Pub 3-09.3. The MISREP should be sent directly to the supported unit or the DASC. Message recipients may provide additional information and forward it via another MISREP.

**Note:** See NWP 3-22.5-AH1, Vol. I, *AH-1 Tactical Manual*, for target area weather information (TARWI) code explanation and use.

**Mission Report**

\_\_\_\_\_, this is \_\_\_\_\_, Mission Number \_\_\_\_\_, MISREP to  
(reporting agency) (call sign)  
follow."

*"Ready to Copy"*

A. Location Identifier \_\_\_\_\_

B. TOT/TOS/Time of Sighting \_\_\_\_\_

C. Results\* \_\_\_\_\_

D. Other Information\*\* \_\_\_\_\_

E. TARVM Code (target area) \_\_\_\_\_

\* Target Results/BD A.

\*\* Vital intelligence, additional sighted enemy activity, and threat updates (times).

**Figure 4-9. Mission Report Briefing.**



## **SECTION II. NIGHT/LIMITED-VISIBILITY CLOSE AIR SUPPORT**

The fundamentals of CAS during the day apply equally to CAS at night and during times of limited visibility. However, night and adverse-weather CAS demand a higher level of proficiency that can be realized only through dedicated, realistic CAS training. Night and limited-visibility CAS relies heavily on systems and sensors and makes terminal controller and aircrew proficiency critically important. Terminal controllers and aircrews must routinely train and exercise CAS procedures and equipment at night and in adverse weather conditions. Specific attack and delivery techniques for night/limited-visibility CAS vary depending on the aircraft. There are three general categories of night/limited-visibility employment: visual, system-aided, and NVG.

### **VISUAL EMPLOYMENT**

During night visual employment, terminal controllers and aircrews must rely on lower ambient light conditions, battlefield fires, or artificial illumination to successfully attack targets. Threat permitting, the use of aircraft lights or flares may be required to see the CAS aircraft.

### **SYSTEM-AIDED EMPLOYMENT**

Aircraft systems (radar, radar beacon, laser, FLIR, and TV) are relied on more at night and in adverse weather because of decreased visual target acquisition ranges and recognition cues. Aircrews and terminal controllers should incorporate redundant methods (e.g., radar, laser, and FLIR) in system-aided attacks while including a

target mark when possible. The temptation to rely on a single system as an information source should be avoided.

### NIGHT VISION GOGGLE EMPLOYMENT

NVGs are an additional sensor for aircrews. NVGs are used together with other systems to allow the detection and attack of targets at night. To fully exploit the potential of NVGs to enhance survivability and mission success, terminal controllers should be equipped with IR marking devices. Terminal controllers and aircrews must ensure that there is no confusion between conventional and NVG terms. Figure 4-10 lists night CAS brevity terms.

Term	Meaning
Rope	Call made by exception if the terminal controller is to illuminate the aircraft with an IR pointer.
Visual	The terminal controller has the attack aircraft in sight, or the attack aircraft has positively identified the terminal controller or friendly position.
Contact	Acknowledges sighting of a specified reference point.
Snake	Call made by exception for the terminal controller to oscillate the beam of an IR pointer about a target. This aids the aircrew in confirming the friendly position while helping maintain sight of the target during conditions when the IR beam/mark is difficult to see.
Sparkle	The terminal controller marks the target with an IR pointer.
Tally	Sighting of a target, bandit, bogey, or enemy position.
Steady	The terminal controller stops oscillation of the IR pointer.
Stop	The terminal controller stops IR illumination of the target.
Note: All terms may be further amplified by including additional words, for example "Contact, Road Intersection."	

**Figure 4-10. Night IR Close Air Support Brevity Terms.**

- **Friendly Marking.** Ground forces can illuminate their position with IR devices. These IR lights should be placed where aircrews overhead can visually acquire and maintain sight of friendly positions. During low illuminance levels, the entire IR beam will be seen with NVDs. The shape of the IR beam can be used to identify the terminal controller and target positions. The IR beam will appear narrower or pencil-like at the terminal controller's position and will appear wider near the target. IR pointers can also be used to direct NVG-equipped aircrews to the terminal controller's position by oscillating the IR pointer to designate to the aircrews the terminal controller's position (the non-moving end of the pointer). Planning an attack axis (preplanned or as directed by the terminal controller) with only a small offset from the controller's pointer-to-target line can also help the aircrews confirm the controller's position.
- **Clearance Parameters.** Aircrews conducting night/limited-visibility CAS must be in positive communication with ground forces. When LTDs are employed, ground forces must hear "Spot," meaning the aircrew has acquired laser energy. When IR pointers are employed, ground forces must hear "Visual" (meaning the terminal controller's position is positively identified) and "Tally" (meaning the enemy position/target is positively identified).
- **CAS Briefing Form.** When using an IR pointer to mark a CAS target, indicate the target mark type in line 7 of the CAS briefing form as "IR" or "IR pointer." Include the pointer-to-target line in the remarks section of the CAS briefing form.

### **SECTION III. CLOSE AIR SUPPORT EXECUTION WITH LASER-GUIDED SYSTEMS**

Laser-guided systems provide the MAGTF with the ability to locate and engage high-priority targets with an increased first-round hit probability. The accuracy inherent in laser-guided systems requires fewer weapons to neutralize or destroy a target. Laser-guided systems can effectively engage a wider range of targets, including moving targets. Laser-guided systems provide additional capabilities, yet have distinct limitations. This section provides CAS-specific TTP and background information on laser-guided system employment. See Joint Pub 3-09.1 for further information on lasers and laser employment.

#### **BASIC REQUIREMENTS**

There are five basic requirements for using LSTs or LGWs:

- Line of sight must exist between the designator and the target and between the target and the LST/LGW.
- The PRF codes of the laser designator and the LST/LGW must be compatible.
- The direction of attack must allow the LST/LGW to sense enough reflected laser energy from the target for seeker lock-on.
- The laser designator must designate the target at the correct time.
- The delivery system must release the weapon within the specific weapon's delivery envelope, while the spot remains on the target through weapon impact.

Environmental factors can affect laser designators and seeker head performance. Aircrews may be required to adjust tactics and techniques when accounting for low clouds and fog, smoke, haze, snow and rain, solar saturation, and other visually limiting phenomena.

## **LASER-GUIDED WEAPONS**

All LGWs home on PRF-coded reflected laser energy. Some LGWs require target designation before launch and during the entire time of flight. Other LGWs require target designation only during the terminal portion of flight. All LGWs require designation through impact. Typical LGWs include the following:

- **Laser-Guided Bombs (LGBs)**
  - PAVEWAY I
  - PAVEWAY II
- **Low-Level LGBs**
  - PAVEWAY III
- **Laser-Guided Missiles (LGMs)**
  - AGM-65E Laser Maverick
  - AGM-114 HELLFIRE
- **Laser-Guided Projectiles**
  - COPPERHEAD

- Semi-active laser, general purpose.

## LASER TARGET DESIGNATORS

Coded LTDs are ground and airborne systems that have two specific purposes. First, they provide terminal weapons guidance for LGWs. Second, they designate targets for coded LSTs. Coded LTDs emit laser energy with a particular PRF and require input of specific laser codes for operation. Codes that are assigned to LGWs correspond to the PRF that harmonizes the designator and seeker interface.

Coded LTDs used for terminal weapons guidance must be set to the same code as the LGW. Certain LGWs, such as LGBs, are coded before takeoff and cannot be changed once the aircraft is airborne. However, all coded LTDs, with the exception of the AC-130H, can change codes while in the tactical environment. (**Note:** The AC-130H's LTD is permanently preset with only one code (1688) and cannot be changed. Terminal weapons guidance of LGBs by an AC-130H is possible provided this code is set. The AC-130U has a codable LTD that allows code changes in flight). For more information on AC-130 employment see Appendix H. Laser code coordination is normally conducted through the joint ATD or CAS briefing form. A designator may serve the dual purpose of designating for an LST and terminal weapons guidance for LGWs. In these cases, the designator, the spot tracker, and the weapon must all have the same code.

The employment of LGBs in conjunction with coded LTDs is either autonomous or assisted. Autonomous LGB employment uses the CAS aircraft's on-board LTD for terminal weapons guidance. Most aircraft capable of delivering LGBs can provide on-board autonomous self-designation. Assisted LGB employment uses an off-board

LTD for terminal weapons guidance. This is typically accomplished by a ground team operating a designator (such as a MULE) or by another aircraft (known as “buddy lasing”). Assisted LGB employment is required by aircraft without on-board LTDs. These aircraft can carry and deliver LGBs but have no on-board terminal weapons guidance capability.

## **LASER SPOT TRACKERS**

LSTs are systems that allow visual acquisition of coded laser-designated targets. LSTs must be set to the same code as the laser target designator for the aircrew to see the target being lased. In the case of airborne LSTs, the aircrew acquires the laser “spot” (target) and either delivers LGBs by using an LTD or executes visual deliveries with nonlaser ordnance. The aircrew can select PRF codes for the LST while in flight. See Appendix C for a listing of aircraft with LSTs.

## **LASER PROCEDURES**

### **Attack Headings**

Terminal controllers provide aircrews with an attack heading. The attack heading must allow acquisition of the reflected laser energy and should be outside the laser designator safety zone. The safety zone is defined as a cone (generally 20 degrees wide) whose apex is at the target and extends equidistant on either side of the target-to-laser designator line. This cone has a vertical limit of 20 degrees. Aircraft may engage targets from above the cone, as long as they remain above the 20-degree limit. The minimum safe altitude for aircraft will vary with the aircraft’s distance from the target.

Aircrew may have difficulty determining the altitude required to remain above the 20-degree vertical limit; aircraft should therefore remain well above these altitudes or maintain the proper lateral separation from the safety zone. (See figure 4-11.)

**Warning: The safety zone is not an absolute safety measure. In some situations, LSTs have acquired the laser energy caused by atmospheric scatter in front of the laser designator even though the LSTs were outside the safety zone.**

At times, the tactical situation may dictate the use of the 20-degree safety zone. This will require extra caution as LGWs launched within the 20-degree safety zone could receive false target indications.

The optimal acquisition/attack zone is inside a 120-degree cone whose apex is at the target and extends to 60 degrees on either side of the target-to-laser designator line, excluding the 20-degree safety zone. This leaves an ideal attack zone of 50 degrees on either side of the safety zone. (See figure 4-12 on page 4-31.)

Generally, LST-equipped aircraft can operate throughout the optimal acquisition/attack zone without hazard to ground personnel operating LTDs. Risk to the laser designator operator may be reduced by increasing the delivery aircraft's altitude/offset angle or the designator-to-target distance.



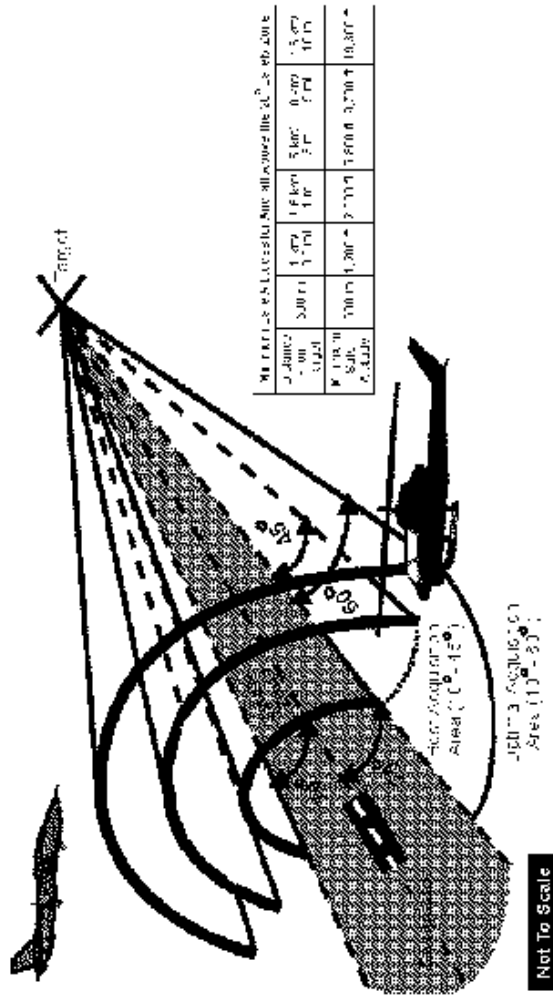
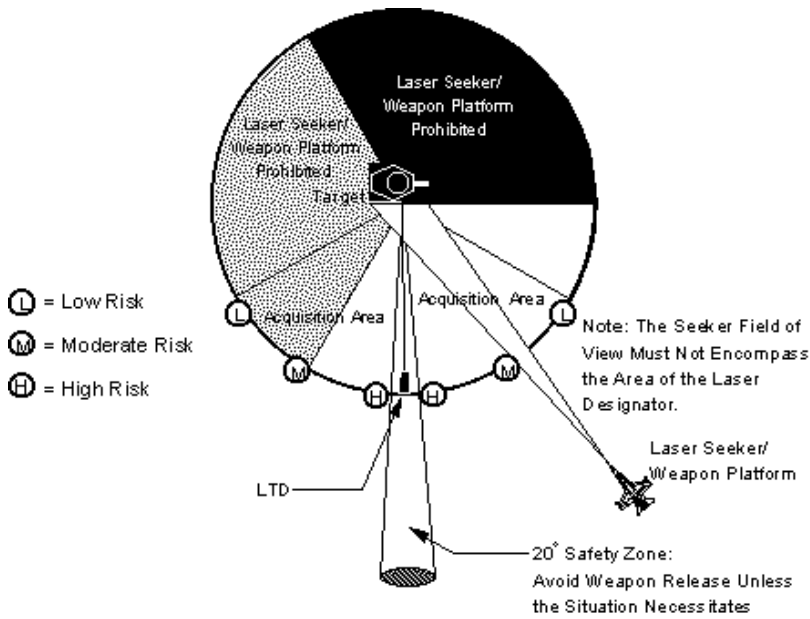

Figure 4-11. Laser Attack Headings and Safety Zone.



**Figure 4-12. Safety Zone and Optimal Attack Zones.**

Although increasing the delivery offset angle improves safety, it may degrade the LST's ability to acquire the laser spot. The best acquisition/attack area is therefore from 10 to 45 degrees on either side of the target-to-laser designator line.

**Attack Angles**

Aircrews release or launch LGWs so the target-reflected laser energy will be within the LGW seeker/LST field of view at the appropriate time. The allowable acquisition or attack angle

(designator-to-target-to-seeker/LST) depends on the characteristics of the weapon system employed. If the angle is too large, the LGW seeker or LST will not receive enough reflected energy to sense the laser spot. In instances where the attack angle positions the weapon seeker or LST field of view to include the laser designator, atmospheric attenuation of laser energy near the designator aperture could cause LGW seeker or LST lock-on. *For this reason, aircrews should not use LSTs as the sole source for target verification.* The CAS aircrew should verify that they are attacking the correct target through additional means (such as visual description, terrain features, nonlaser target marks, etc.) to preclude inadvertent weapon seeker or LST lock-on at or near the designator. *Whenever possible, planned attacks should avoid placing the designator in the field of view of the LST or LGW.*

### **Coordination With Terminal Controller**

Laser-guided systems improve the delivery accuracy of unguided ordnance. If the attack aircraft has an LST, the terminal controller can designate the target for aircrew identification. An aircrew can use the LST to visually locate the target. Once the target is located, the aircrew can conduct an accurate attack by using unguided ordnance. Aircraft equipped with LTDs can also be “talked onto” the target by the terminal controller, then designate the target and deliver the weapon by using their own spot. Final clearance to release still comes from the terminal controller. The standard laser brevity terms listed in figure 4-13 should be used.

### **Laser Designation Time**

The aircrew may request a longer “laser-on” time based on munitions characteristics. If communications are unreliable, the terminal

controller should begin designating 20 seconds before TOT or with 20 seconds remaining on TTT (unless the aircrew is using a loft delivery). Reducing laser operating time is important in a laser countermeasure environment or when using battery-operated designators. Offset lasing should also be considered where a target laser warning receiver capability exists. Nevertheless, designation time must be long enough to guarantee mission success.

<b>Call</b>	<b>Meaning</b>
Ten Seconds	Directive call to standby for "Laser On" call in approximately 10 seconds.
Laser On	Directive call to start laser designation.
Spot	Acquisition of laser designation.
Shift	Directive call to shift laser illumination.
Terminate	Cease laser illumination of the target.

**Figure 4-13. Standard Laser Brevity Terms.**

## **SECTION IV. FIXED-WING EXECUTION**

This section identifies the TTP used by fixed-wing aircrews to conduct CAS. Standardized procedures and tactics provide a baseline for further refinement and improvement. Commanders should adjust these TTP as the combat situation develops. Aircrews can build on these basic TTP by using innovative thinking, experience, and the information from aircraft tactical manuals to improve CAS.

### **LAUNCH AND DEPARTURE PROCEDURES**

Based on the recommendations by the GCE and ACE commanders, the MAGTF commander sets required response times for on-call aircraft. The appropriate air C2 agency issues launch orders to the ground alert aircrew. This may require land-line or courier communications.

### **EN ROUTE TACTICS (BEFORE THE CONTACT POINT)**

Ideally, en route tactics allow CAS aircrews to avoid concentrated enemy air defenses and prevent early enemy acquisition of the attack force. If en route tactics are successful, they can delay or hamper enemy air defense coordination and increase aircrew survival and mission success.

### **Techniques**

Aircrews and mission planners use support aircraft and other countermeasures to degrade the threat. Aircrews, terminal controllers, and air controllers select routes that avoid known threat weapon

envelopes. Routes should include course changes to confuse and deceive the enemy concerning the intended target area. Aircrews use formations that complicate enemy radar resolution and improve lookout capability against enemy fighters. Aircrews constantly watch for air defense weapons. Aircrews use electronic protection and radar warning receiver/radar homing and warning equipment to detect and defeat enemy air defense systems. Aircrews should delay entry into a heavily defended target area until they have a clear understanding of the mission.

### Navigation

En route navigation tactics depend on the threat, the need for and availability of support aircraft, friendly air defense requirements, weather, and fuel. En route navigation tactics include the use of high altitude, medium altitude, low/very low altitude, or a combination of the above.

- **High Altitude.** High-altitude en route tactics are flown higher than 15,000 feet above ground level (AGL). Aircrews use high-altitude tactics to remain above short-range air defenses. Advantages of high-altitude tactics include:
  - Reduced fuel consumption rate
  - Reduced navigation difficulties
  - Improved formation control
  - Increased maneuver airspace, which allows aircrews to concentrate on mission tasks instead of terrain avoidance tasks

- Improved communications, unaffected by terrain, between aircrew and control agencies
- Reduced exposure to certain AAA and man-portable IR SAMs.
- Disadvantages of high-altitude tactics include:
  - Enemy acquisition radar can detect the attack force at long range. (This allows the enemy to prepare its air defenses.)
  - The attack force may be vulnerable to some enemy SAM systems and enemy fighter interceptors before entering the target area if local air superiority has not been achieved.
  - Weather may prevent visual navigation and obscure the target area.
- **Medium Altitude.** Medium-altitude en route tactics are flown between 8,000 feet AGL and 15,000 feet AGL. Medium-altitude tactics may not be advisable in a medium- or high- threat environment. Medium-altitude tactics have many of the same advantages and disadvantages as high- and low-altitude tactics.
- **Low/Very Low Altitude.** Low-altitude en route tactics are flown below 8,000 feet AGL. Very low altitude is flight below 500 feet AGL. Aircrews use low-/very-low-altitude tactics to keep the attack force below enemy early warning/ground-control intercept (GCI) radar coverage for as long as possible. Adverse weather can cause aircrews to use low-/very-low- altitude navigation. Advantages of low-/very-low-altitude tactics include:
  - Reduced enemy radar detection by using the earth's curvature for masking

- Reduced chance of attack from enemy SAW systems by using terrain for masking
- Degraded enemy GCI radar coverage (This denies intercept information to enemy fighters and forces enemy aircraft to rely on visual or onboard acquisition systems.)
- Reduced enemy weapons envelope lethal zones during high-speed, low-altitude ingress
- Improved friendly aircraft maneuvering performance.
- Disadvantages of low-/very-low-altitude tactics include:
  - High fuel consumption rates
  - Extremely demanding navigation that requires a high level of aircrew skill (Navigation is easier for aircraft equipped with INS or GPS.)
  - Increased exposure to small arms, AAA systems, and IR-guided weapons
  - Difficulty in communication and control
  - Reduced target acquisition.
- **Combination of Low/Very Low, Medium, and High Altitude.**  
Aircrews combine low-/very-low- and medium-altitude tactics to gain the advantages of both while reducing the disadvantages of each. The en route portion of the flight is normally beyond the range of enemy air defense weapons and flown at a medium or high altitude. The attack force descends to low/very low altitude to avoid detection by certain enemy SAM threats and/or gain surprise.



## INGRESS TACTICS (CONTACT POINT TO INITIAL POINT)

Ingress tactics apply from arrival at the CP until the target attack phase begins at the IP. The expected threat intensity and sophistication influence the selection of ingress tactics. Terminal controllers and aircrews tailor communications and control requirements to counter the threat. Normally, control of CAS flights is handed over to the terminal controller at the CP. In an intense jamming environment, preplanned scheduled missions may be the primary CAS method. Proper planning provides for mission success even if there is little or no chance of radio communications after the flight becomes airborne.

### Navigation

Ingress tactics depend on the threat, the need for and availability of support aircraft, weather, and fuel. Ingress navigation tactics include high altitude, medium altitude, low/very low altitude, and a combination of low/very low and medium altitude.

- **High Altitude.** Aircrews use high-altitude ingress tactics to remain above the enemy AAA and short-range SAM threat. High-altitude ingress reduces fuel consumption rates and eases navigation.
- **Medium Altitude.** Medium-altitude ingress tactics are a continuation of medium-altitude en route tactics. Aircrews can use medium-altitude ingress tactics if support aircraft, air strikes, artillery strikes, or onboard electronic protection equipment can suppress the enemy air defense threat or if they can remain above the enemy SAW threat. Medium-altitude ingress reduces fuel consumption rates and eases navigation. These tactics may

provide better CAS for the requesting commander than low-/very-low-altitude methods.

- **Low/Very Low Altitude.** In high- and medium-threat environments, aircrews use low-/very-low-altitude ingress tactics to degrade enemy detection capabilities. These tactics can increase aircrew survivability but also increase fuel consumption rates. Extensive training is required to develop accurate navigation techniques and the ability to perform effective evasive maneuvers. Detailed planning is critical. Aircrews plot, brief, and study the ingress routes to gain the maximum advantage from terrain masking.

Extreme terrain can dictate that the size of each attack element be small if flying low/very low altitudes. The terrain dictates the type of formation flown by the attack element.

Fixed-wing aircrews must maintain adequate clearance from helicopter flights. Helicopter aircrews using terrain flight (TERF) techniques must remain close to the terrain. This becomes critical when fixed-wing aircrews traverse vertically-developed terrain.

- **Combination Low/Very Low and Medium Altitude.** The attack force enters the target area at low/very low altitude to avoid early enemy radar detection. At a predetermined point, the attacking force climbs to medium altitude for the attack.

This tactic protects the attack force from early engagement by enemy long-range SAW systems and fighter aircraft. The climb to medium altitude removes the attack force from the low-altitude AAA and short-range IR missile envelopes and aids target acquisition. This tactic does increase the attacking force's vulnerability to SAW systems in the target area but is designed to beat SAW system reaction times.

Aircrews should consider this tactic when AAA is the major threat in the target area. This tactic includes climbing to a medium altitude before entering the lethal zone of LAAD weapons. The climb should be delayed as long as possible to reduce vulnerability to long-range air defense systems.

- **Communications and Control.** Communications and control procedures at the CP vary by the type of CAS, the threat, the support package, communication capabilities, and planned ingress tactics. A preplanned, scheduled mission may require little or no communications. However, an immediate mission will probably be very communications-intensive. In the presence of an EW threat, communications discipline becomes more important, as effective communications may be considerably more difficult to conduct.
- **Mission-Essential Information.** The aircrew must receive mission-essential information before arriving at the target area. If communications at the CP permit, missions may be launched without specific targets or IP assignments. Such flights receive only a CP and a terminal controller call sign/frequency either before launch or from an air control agency once airborne. The aircrew receives the rest of the target brief at the CP. Aircrews may have to divert or abort if they are unable to receive mission-essential briefing items.
- **Flexible Communications.** Communications between the aircrew and the terminal controller may be difficult or nonexistent. If the terminal controller cannot talk to the aircrew, the appropriate air control agency must pass mission-essential information.
- **Minimum Communications.** Preplanned, scheduled missions leave the CP to meet a TOT/TTT with minimal communications. The terminal controller makes brief, coded

transmissions or assignment changes. Airborne alert aircraft remain at a CP for immediate mission assignment. Aircrews given immediate CAS missions plan fuel or time cutoff points. The CP location may not allow communication between aircrews and terminal controllers because of radio range or line-of-sight considerations. Aircrews should expect communication problems and plan to use other air control agencies to provide radio relay.

### **ATTACK PHASE (INITIAL POINT TO TARGET)**

The attack phase, or the final run-in from the IP to the target, is the most crucial phase of the CAS mission. Aircrew tasks increase because the aircrew must follow a precise timing and attack profile to produce the necessary effect on the target in a timely manner. Figure 4-14 illustrates the attack phase of a typical fixed-wing CAS mission.

#### **Attack Tactics**

Attack tactics permit integration of CAS attacks into fire support plans. Specific techniques used to attack a target are the choice of the pilot in command or the mission commander. Because of the risk to friendly ground forces, the FAC should avoid loft attacks with weapons release behind friendly positions.

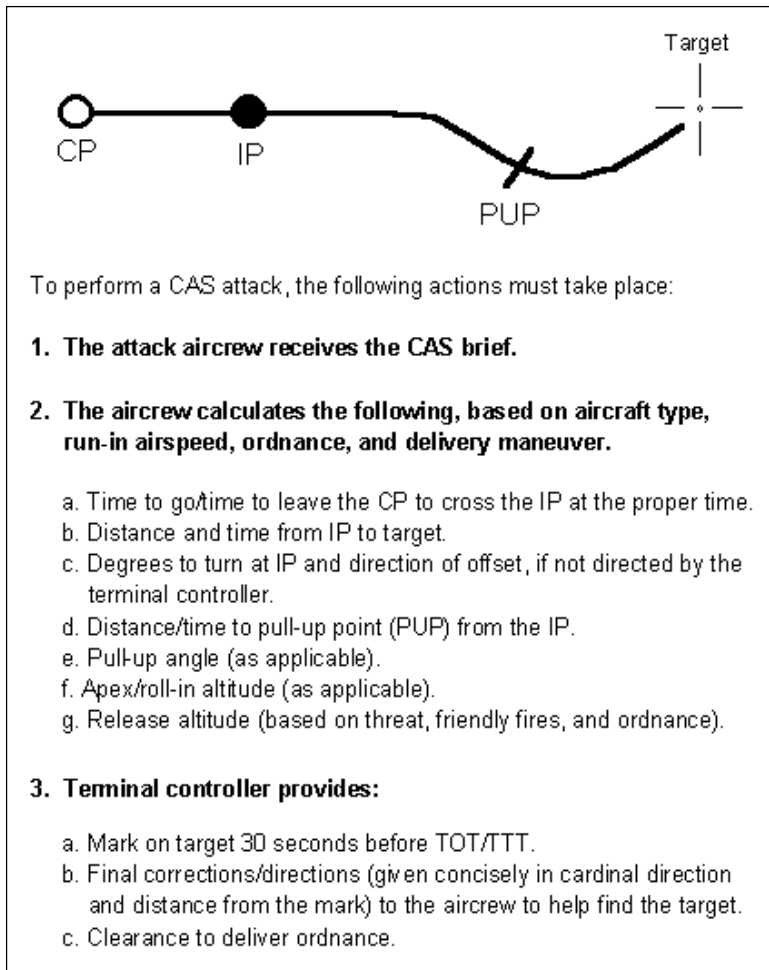

**Figure 4-14. Key Actions in a Fixed-Wing Close Air Support Attack.**

- **High/Medium Altitude.** High-/medium-altitude attacks are normally executed in a low-/medium-threat environment. However, aircrews can perform a high-/medium-altitude attack after any type of ingress. High-/medium-altitude attack advantages and disadvantages are similar to those listed in the discussion on en route tactics. More time may be available for target acquisition, but bombing accuracy may be degraded. Terminal controllers can issue to aircrews minimum altitude restrictions that reduce aircraft vulnerability to indirect fires. High-/medium-altitude tactics may prevent the terminal controller from visually acquiring the aircraft.
- **Low/Very Low Altitude.** During low-/very-low- altitude attacks, the same considerations apply as in high-/medium-altitude attacks. Aircrews may have less time to acquire the target and position their aircraft for a successful attack. When planning ordnance and attack profiles, consider the requirement for fragmentation pattern avoidance in the low-altitude environment.
- **Multiple Axes of Attack.** Tactical formations using multiple axes of attack provide effective mutual support throughout the attack. Multiple axes of attack increase the concentration of ordnance on target and force the enemy to split air defense assets. The size of the attack force depends on control requirements, time of exposure to enemy defenses, and time available in the target area. Multiple axes of attack depend on the threat. Regardless of the attack profile, the briefing format remains the same.
- **Deconfliction Procedures.** The following procedural guidelines are considered standard: Aircraft in the route of egress from the target must have the right-of-way; reattacks must be approved by the terminal controller after coordination with the ground force commander; if an aircraft enters another flight's sector, the aircrew must immediately notify the other

flight, the terminal controller, and deconflict or exit that sector; munitions that may enter the other flight's sector must be coordinated before the attack.

## Procedural Control Measures

Terminal controllers use procedural control measures to provide target orientation for the aircrew; to align aircraft for the attack or egress; to provide separation from other supporting fires; to provide separation from enemy air defense weapons; and to provide procedural control measures that include IP selection, offset direction, and attack heading.

- **IP Selection.** The terminal controller selects the IP based on enemy capabilities, target orientation, friendly location, weather, and fire support coordination requirements. IPs should be radar- and visually-significant and normally located from 5 to 15 NM or 1 to 2 minutes from the target. If aircrews are not restricted, they are free to ingress and attack the target from any direction after they leave the IP. Attacks should have as few restrictions as possible.
- **Offset Direction.** The offset direction tells the aircrews on which side of the IP-to-target line they can maneuver for the attack. See figure 4-15 to understand the relationship between offset direction and IP-to-target heading. Terminal controllers use an offset direction to ease fire support coordination, aid target acquisition, align the aircraft for the attack or egress, or keep aircrews away from known threats.

An offset direction aids fire support coordination by restricting aircrews from using airspace on the other side of the IP-to-target

line. An offset direction keeps aircraft clear of enemy air defenses and reduces interference with gun target lines. It also reduces an aircrew's chance of being hit by direct/indirect fires. The offset direction regulates the attack quadrant without assigning a specific attack heading.

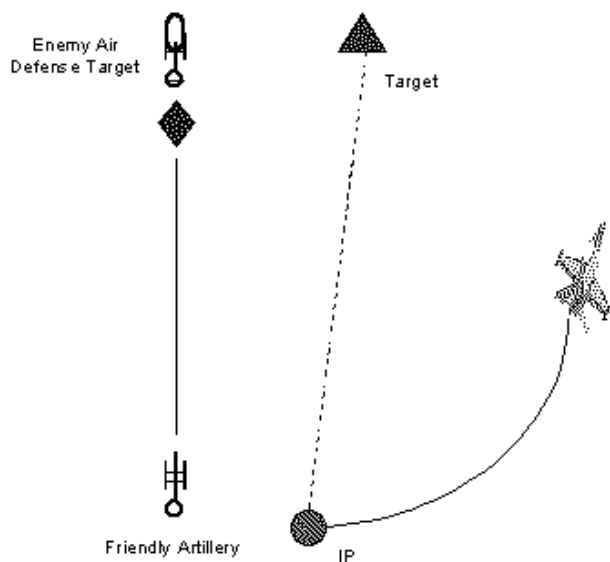

Offset Right Example

Plot an IP and a target and connect them with a straight line. Specify the offset direction as either right or left. If told to offset right, as in the example above, proceed on or to the right of this line while inbound to the target. Aircrews cannot fly to the left of this line. An offset restriction applies from the time aircrews leave the IP until ordnance is released and egress begins.

**Figure 4-15. Offset Direction.**

### Types of Delivery



- **Level Delivery.** Ordnance is delivered with a wings-level pass over the target.
- **Dive Delivery.** Ordnance is delivered by using a dive delivery.
- **Loft Delivery.** To execute a loft delivery, the aircrew proceeds inbound to the target from the IP. At a calculated point, the aircrew starts a loft maneuver pull up. Once released, the weapon continues an upward trajectory while the aircrew egresses the target area. After the weapon reaches the apex of its trajectory, it follows a ballistic path to impact. (**Note:** If the delivery is conducted over friendlies, ground commander approval is required.)
- **Pop-up Delivery.** To execute a pop-up delivery, the aircrew proceeds to the target from the IP at low/very low altitude. As the aircrew nears the target, they pop up to the desired altitude and execute a dive delivery.

## Final Attack Heading

A final attack heading is the assigned magnetic compass heading that an aircrew flies during the ordnance delivery phase of the attack. Terminal controllers assign final attack headings for several reasons: to increase ground troop safety, to aid in laser spot or target acquisition, and to help fire support coordination.

Final attack cones may be used to satisfy the same requirements of the final attack heading while offering increased flexibility. A final attack cone is an assigned range of magnetic compass headings that an aircrew may fly during the ordnance delivery phase of the CAS attack. The terminal controller assigns the magnetic headings for the left and right boundaries of the cone (e.g., “restriction— final attack heading between 090 degrees and 135 degrees”). This limits

the CAS aircraft to the range of final attack headings falling within, and inclusive of, the boundary headings. This technique may aid the terminal controller in visually acquiring the aircraft while increasing CAS aircrew flexibility and survivability.

### **Immediate Reattacks**

The aircrew's goal is to complete a successful attack on the first pass. Once acquired by the enemy in the target area, an aircraft that remains for reattacks may be more vulnerable. In low- and medium-threat environments, immediate reattacks may be a practical option, although single-pass attacks require less time in enemy air defense envelopes. A reattack can help assure the desired effect on the target, aid visual orientation for the aircrew, and increase responsiveness to the supported commander.

- **Terminal Controller Responsibilities.** Terminal controllers authorize reattacks. If a reattack is necessary and possible, the terminal controller may give the aircrew a pull-off direction and may assign different attack headings. The terminal controller may provide additional target marks for the reattack. The terminal controller can describe reattack target locations by using the last mark, last hit, terrain features, or friendly positions. The reattack may engage other targets within a specific target area.
- **Reduced Threat Considerations.** Often threat conditions allow aircrews to loiter safely in the target area. This may be a high loiter, to stay above effective AAA fire, or a lower loiter if there is no effective AAA threat. In this case, a "wheel" may be flown around the target. Advantages are:
  - Continued observation of the target area, the marks, and hits from other aircraft by all flight members

- Improved mutual support
- Increased ability to roll-in from any axis requested by the terminal controller
- Lower fuel consumption and increased TOS
- Easier timing of TOT
- Better ability to conduct reattacks.

### **FIXED-WING LASER-GUIDED SYSTEM EMPLOYMENT**

Laser systems offer improved CAS weapons delivery capability and accuracy. However, they require detailed coordination and additional procedures. See Joint Pub 3-09.1 for more information.

#### **Types of Employment**

- **Laser Acquisition and LGWs.** Typically, this combination requires the longest period of laser designation and can provide the best results. Laser designation must allow the aircraft's LST adequate time to find the target. Laser designation may begin 20 seconds before planned TOT/TTT. Designation continues until ordnance impact. If communications permit, the aircrew may give "10 Seconds," "Laser On," "Spot," and "Laser- Off" calls.
- **Laser Acquisition and Unguided Weapons.** This combination produces excellent results if the delivery aircraft has some type of computer-aided release system. Laser designation can begin before or shortly after the aircraft crosses the IP. The aircrew

may give a “Laser On” call if communications permit. Designation continues until all ordnance has impacted the target or the aircrew calls “Terminate.”

- **LGWs Only.** This combines “dumb” aircraft (no LST or LST failure) and “smart” (laser-guided) weapons. A supplemental mark (e.g., smoke) must be visible to the aircrew for them to be able to locate the target. Unless coordinated otherwise, designation should begin with ordnance release and continue until impact.

## Employment Considerations

- **LGBs.** If designating for LGBs, terminal controllers and designator operators must consider the following:
  - Older LGBs have preset codes that cannot be changed.
  - Some newer LGBs have codes that are manually set before the aircraft launches. *Aircrews cannot change these codes while airborne.* On check-in, aircrews pass the designator code to the terminal controller.
  - Certain aircraft/LGW combinations allow in-flight cockpit selection of codes.
  - The terminal controller selects the IP/offset to ensure that the attack heading allows LST lock-on and ordnance delivery on the first pass.
  - Aircraft carrying both guided and unguided ordnance release LGBs first. This allows the LGB a relatively dust- and debris-free environment and helps reduce interference. Unguided bombs are dropped during later passes.

- LGBs provide greater accuracy.
- Because there is an increased hazard to friendly forces when aircrews release weapons behind friendly lines, the approval of the ground commander is required.
- Designators should coordinate “Laser On” times with the aircrew. The aircrew provides “Laser On” and “Laser Off” radio calls to the designator.
- **LGMs.** LGMs for fixed-wing aircraft include the AGM-65E Maverick. LGMs generally provide greater standoff launch ranges than LGBs. Greater range provides increased survivability for aircrews operating in a high-threat environment. Aircrews and terminal controllers must exercise caution when launching LGMs from behind friendly troops. Without a TOT or TTT, the aircrew gives a “10 Seconds” warning call to the terminal controller. This alerts the terminal controller to begin laser designation in 10 seconds. The aircrew gives a “Laser On” call to begin target designation. The aircrew may call “Laser Off” to end designation.
- **Laser Maverick Employment.** The Maverick system allows aircrews to engage targets designated by either air or ground sources with in-flight selectable PRF codes. In the event that the laser signal is lost, the weapon will safe itself and overfly the target. The missile and the laser designator must be set to the same PRF code before launch, and the missile must be locked-on to a laser source before launch. For other than self-designation, the attack heading must be adjusted to optimize the reflected laser energy.
- **Attacks by Multiple Aircraft.** Use of laser designators and LST-equipped aircraft simplifies rapid attacks by multiple aircraft. If numerous aircraft operate under the control of a single

terminal controller and use the same heading (threat permitting), it simplifies control of the attack.

- **Attacks on a Single Target.** Multiple aircraft attacking a single target increase the chance of target destruction at the earliest possible time. The attack requires a single designator with one (or all) aircraft achieving lock-on and ordnance release. The terminal controller may clear the second aircrew to perform a follow-up attack on the target using guided or unguided ordnance.
- **Attacks on Multiple Targets.** Multiple aircraft attacking multiple targets require increased coordination and planning. Attacks on multiple targets can be performed by using a single designator or multiple designators. Separate designators on different codes for each target are preferred. Using multiple designators reduces the time any single designator is on and exposed to enemy countermeasures.

## EGRESS

In a high-threat environment the need for a rapid egress may delay the ability to rendezvous and regain mutual support. Egress instructions and RPs should avoid conflict with ingress routes and IPs. Egress instructions may be as detailed as ingress instructions. Egress fire support coordination and deconfliction requirements are the same as those used during ingress. On completion of the mission, aircrews follow the egress instructions and either execute a re-attack, return to a CP for future employment, or return to base.

## **SECTION V. ROTARY-WING EXECUTION**

Rotary-wing CAS execution differs in some aspects from fixed-wing CAS execution primarily because of the difference in aircraft performance and flight regimes. This section identifies some of the TTP that attack helicopter aircrews can use to perform the CAS mission. These TTP should not be interpreted rigidly. Rigid standardization reduces flexibility and results in predictability. However, CAS TTP involve close coordination between ground units, aircrews, and control agencies, and therefore some standardization is necessary. Standard tactics provide aircrews with a baseline for further refinement and change. Operation plans and orders reflect initial standardization criteria. Commanders should adjust these procedures as the tactical situation dictates. Aircrews take advantage of initiative, imaginative thinking, experience, and basic aviation tactics found in aircraft tactical manuals to refine and improve mission tactics.

### **LAUNCH AND DEPARTURE PROCEDURES (TAKEOFF TO RENDEZVOUS POINT)**

Rotary-wing aircraft should be positioned near the supported commander to reduce response time or increase TOS. The appropriate controlling agency issues launch orders through the proper C2 or fire support agency.

### **EN ROUTE TACTICS (RENDEZVOUS POINT TO HOLDING AREA)**

Ideally, en route tactics (route and altitude selection, TERF profile, and formations) allow rotary-wing aircrews to avoid concentrated

enemy air defenses and prevent early enemy acquisition of the attack force. If en route tactics are successful, they can delay or hamper enemy air defense coordination and increase aircrew survival and mission success.

### Navigation

En route navigation tactics depend on the threat, the need for and availability of support aircraft, friendly air defense requirements, weather, and fuel. In some circumstances, missions may be conducted above TERF altitudes (1,500 feet and above). Examples are missions during which the enemy threat consists of small arms only and during which early detection of CAS aircraft would not adversely affect mission accomplishment. Otherwise, as rotary-wing CAS aircraft approach the target area or probable point of enemy contact, they fly lower and with increased caution to arrive undetected in the HA. Aircrews use TERF to deny/degrade the enemy's ability to detect or locate the flight visually, optically, or electronically. En route TERF profiles fall into three categories: low level, contour, and nap of the earth (NOE).

- **Low Level.** Low-level flight is conducted at a constant airspeed and altitude above MSL. Low-level flight reduces or avoids enemy detection or observation. Aircrews use low-level flight to reach a control point in a low-threat environment.
- **Contour.** Contour flight conforms to the contour of the earth or vegetation to conceal the aircraft from enemy observation or detection. Contour flight uses varied airspeeds and altitudes above MSL as vegetation and obstacles dictate. Aircrews vary MSL altitude to produce constant altitude AGL. Aircrews use contour flight until reaching a higher threat area.



- **NOE.** NOE flight is as close to the earth's surface as vegetation and obstacles permit while following the earth's contours. Terrain and vegetation provide the aircraft with cover and concealment from enemy observation and detection. NOE flight uses varied airspeeds and altitudes AGL based on the terrain, weather, ambient light, and the enemy situation. When flying NOE, aircrews may maneuver laterally within a corridor that is compatible with the ground scheme of maneuver and assigned route structures. Within the corridor, aircrews use a weaving, unpredictable path to avoid detection by the enemy. NOE flight should be used in high-threat environments.

### **INGRESS TACTICS (HOLDING AREA TO BATTLE POSITION)**

Ingress tactics apply from arrival at the HA until the target attack phase begins at the BP.

#### **Control Points**

Terminal controllers and aircrews select HAs and BPs that are tactically sound, that support the scheme of maneuver, and that are coordinated with other supporting arms. Rotary-wing CAS can be performed with or without HAs or BPs.

- **HAs.** HAs may be established throughout the battlefield to be used for rotary-wing aircraft awaiting targets or missions. These HAs serve as informal ACAs while they are in use. HAs provide the rotary-wing CAS aircrew with an area in which to loiter. HAs may be established during planning, referred to by name or number, and activated/established during operations.

- **BPs.** BPs are maneuvering areas that contain firing points for attack helicopters. Like HAs, BPs serve as informal ACAs while in use. Planning considerations and methods of establishment for BPs are the same as those used for HAs.
- **IPs.** IPs may be used by rotary-wing aircraft in the same manner as they are used by fixed-wing CAS aircraft. Rotary-wing aircraft proceed from an HA/BP to the IP to commence a running fire attack.

**Techniques of Movement**

Due to proximity to the threat, aircrews use TERF to move from the HA to the BP. If aircrews are close to friendly artillery and mortars, they use TERF in conjunction with airspace control measures to de-conflict with artillery and mortar trajectories. Aircrews use three techniques of movement in TERF: traveling, traveling overwatch, and bounding overwatch. When flying TERF, rotary-wing aircraft movement must be coordinated with the applicable FSCC/SACC. (See figure 4-16.)

Techniques of Movement	Likelihood of Contact	TERF Profile
Traveling	Remote	Low Level or Contour
Traveling Overwatch	Possible	Contour or NOE
Bounding Overwatch	Imminent	NOE

**Figure 4-16. Movement Techniques.**

- **Traveling.** Traveling is a technique that aircrews use when the possibility of enemy contact is remote. The flight moves at a constant speed using low-level or contour TERF. Movement should be as constant as the terrain allows. Traveling allows rapid movement in relatively secure areas.
- **Traveling Overwatch.** Traveling overwatch is a technique that aircrews use when enemy contact is possible. The flight moves by using contour or NOE TERF. Although caution is justified, speed is desirable. The flight consists of two major elements: the main element and the overwatch element. The overwatch element may contain multiple subelements. The main element maintains continuous forward movement. The overwatch elements move to provide visual and weapons coverage of the main element. The overwatch elements provide weapons coverage of terrain from which the enemy might fire on the main element.
- **Bounding Overwatch.** Bounding overwatch is a technique that aircrews use when enemy contact is imminent. The flight moves using NOE TERF. Movement is deliberate, and speed is not essential. The flight consists of two elements. One element moves, or “bounds,” while the other element takes up an overwatch position. The overwatch element covers the bounding elements from covered, concealed positions that offer observation and fields of fire.

## Communications and Control

A rotary-wing aircraft's inherent flexibility allows a variety of communication and control procedures. TERF techniques of movement restrict the terminal controller's ability to exercise control through radio communications. Typically, communications may not be desirable during the ingress phase. To preserve operational security,

aircrews can land to receive face-to-face mission briefs and mission-essential information from the supported commander or terminal controller before leaving the HA. An airborne relay may be used to maintain communications.

### **ATTACK PHASE (WITHIN THE BATTLE POINT)**

The attack phase is the most important phase of the rotary-wing CAS mission. The attack must produce the necessary effect on the target in a timely manner. Figure 4-17 illustrates an example of a rotary-wing CAS attack.

#### **Control**

Once the aircrews reach the BP, the terminal controller or mission commander issues final instructions to the flight. Aircrews select individual FPs and remain masked while awaiting the TOT/TTT.

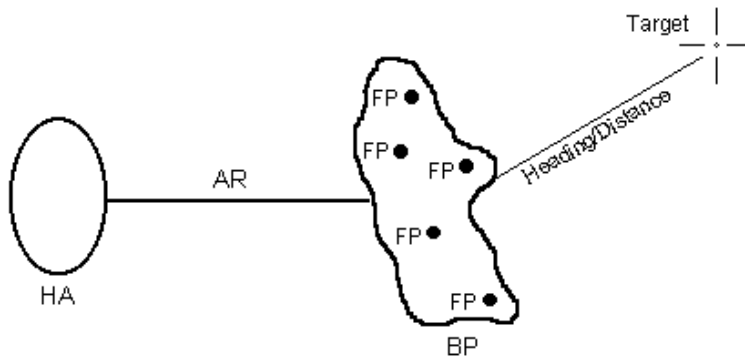

**Figure 4-17. Rotary-Wing Close Air Support Attack Phase Example.**

### Attack Tactics

The specific techniques used to attack a target are the choice of the AMC. Attack tactics are determined by considering the threat, target size and vulnerability, the weather, the terrain, accuracy requirements, weapons effectiveness, and fragmentation patterns.

- **Hovering Fire.** Hovering fire is performed when the aircraft is stationary or has little forward motion. Aircrews perform hovering fire after unmasking from a defilade position. To prevent being targeted by enemy weapons, aircrews maintain the hovering fire position for only short periods. Indirect hovering fire should be delivered from FPs hidden from the enemy by terrain features. After delivering hovering fire, aircrews remask behind terrain. If the terrain permits, aircrews should move to an alternate FP. Unguided ordnance (rockets, cannons, or 20-/25-/30-mm gunfire) is normally less accurate because the aircraft is less

stable in a hover. Precision-guided weapons are the most effective ordnance fired from a hover.

- **Running Fire.** Running fire is performed when the aircraft is in level, forward flight. Forward flight adds stability to the aircraft and improves the accuracy of weapon delivery. Running fire used at TERF altitudes reduces an aircrew's vulnerability to enemy air defenses. Running fire offers a moving target and produces a smaller dust or debris signature than is produced in hovering fire. While performing running fire, aircrews can use direct or indirect fire techniques. Aircrews must be constantly aware of the direction and trajectory of all ordnance to be released. Running fire attacks may require the aircraft to fly outside the BP to effectively engage targets. This will necessitate clearance from the terminal controller after coordination and deconfliction with other supporting arms.
- **Unmasked Fire.** Unmasked fire is a combination of running and diving fire. Aircrews climb slightly and then perform a shallow-angle dive. Unmasked fire provides aircrews with the protection from enemy air defenses of running fire and the increase in accuracy of diving fire.
- **Diving Fire.** Diving fire is delivered while the aircraft is at altitude and in descending forward flight. If delivering unguided ordnance, diving fire may produce the most accurate results. Diving fire should be used if the aircrew can remain above or outside the threat envelope. Diving fire is particularly useful in a small-arms or limited-air-defense threat environment.

### Scout/Attack Team Tactics

Scout/attack teams provide a highly mobile, powerful, combined-arms capability while executing CAS. They consist of two or more

rotary-wing aircraft acting in the scout and attack roles. This capability allows the scout/attack team to quickly and effectively react to a rapidly changing battlefield. Commanders can use the scout/attack team separately, as a reinforcing asset, or reinforced with other assets. Team elements consist of:

- **Scout Element.** The scout element contains one or more rotary-wing aircraft. Multiple aircraft are preferred to provide mutual support within the scout element. The AMC is normally a member of the scout element. He is responsible for CAS mission planning and execution. The AMC's duties include providing liaison and coordination between the scout/attack team and the supported unit to receive the current situation and mission brief, providing reconnaissance of the HA and BP if time and threat permit, briefing the attack element, planning and coordinating target marking/designation, providing security for the attack element from ground and air threats, and controlling the mission's supporting arms.
- **Attack Element.** The attack element contains a minimum of two rotary-wing aircraft. The attack element is subordinate to the mission commander. The attack element leader's duties include assuming all the duties of the mission commander if required and attacking specified CAS targets with the proper ordnance.

## **DISENGAGEMENT AND EGRESS**

Following the attack, the CAS flight disengages and egresses from the BP. Egress instructions may be as detailed as ingress instructions. Egress fire support coordination and deconfliction requirements are the same as those used during ingress. On mission completion, the flight can:

- Proceed to an alternate BP
- Return to the HA for further operations
- Return to the FARP for refueling/rearming
- Return to the FOB/ship.

### **ROTARY-WING LASER-GUIDED SYSTEMS EMPLOYMENT**

The AGM-114 HELLFIRE missile allows attack helicopters to engage targets with precision LGWs. Aircrews use the HELLFIRE system to engage critical hardpoint targets at extended ranges. The HELLFIRE system provides the ability to engage multiple targets simultaneously, allows aircrews to select or change missile-seeker PRF codes from the cockpit, increases standoff and lethality, and reduces the risk to aircrews by reducing or eliminating exposure time. Figure 4-18 illustrates an example of a HELLFIRE designator exclusion zone. HELLFIRE employment considerations include designator/launcher separation angle, aircrew/designator coordination, weather effects and obscurations, and enemy countermeasures.

**Figure 4-18. HELLFIRE Designator Exclusion Zone.**



## Coordination

When coordinating engagement procedures for HELLFIRE-equipped aircraft, terminal controllers and aircrews consider the following factors:

- Communications between the terminal controller, laser designator, and aircrews must be adequate.
- The terminal controller must provide accurate target location information and laser-to-target line to the aircrew.
- The PRF code settings must be coordinated before the attack.
- The number of missiles and the interval between missiles for rapid or ripple fire must be decided.
- Proper geometry between the laser, the target, and the attack aircraft must exist to maximize the probability of kill.

## Characteristics

The HELLFIRE LGM homes on targets designated by U.S. and NATO laser designators. The HELLFIRE system should use PRF codes in the range of 1111 to 1688 to achieve the desired probability of a hit. The HELLFIRE system allows the aircrew to conduct multiple, rapid launches by using one or two designation codes simultaneously. The aircrew can set or change the PRF code from the cockpit. If using a single designator, the aircrew delays launching subsequent missiles (all set on the same PRF code) until the terminal controller shifts the laser designator to the next target. If using two designators (each set to a different PRF code), the missile launch interval can be less than 2 seconds. The use and coordination

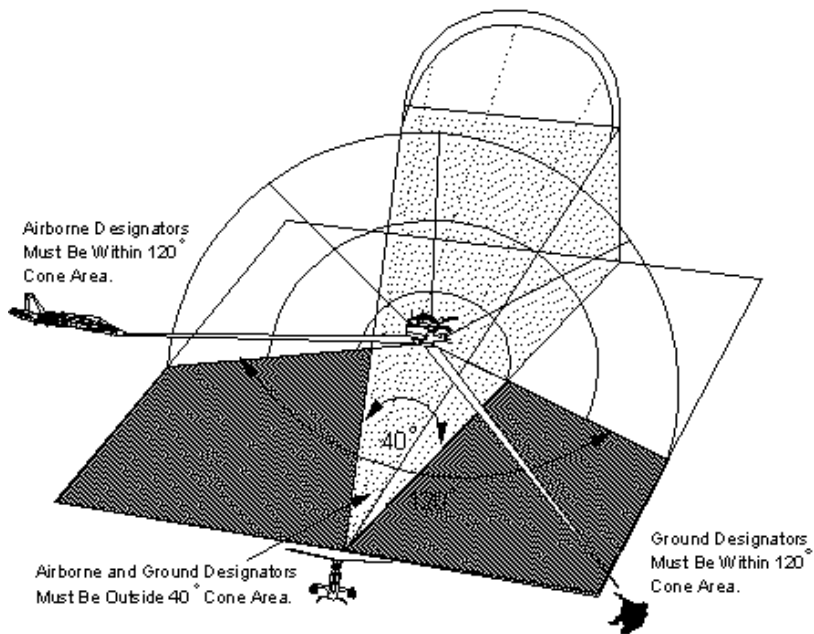

of multiple designators presents a complex problem for the aircrew and the terminal controllers.

### HELLFIRE Missile Lock-On Options

- **Lock-On Before Launch (LOBL).** Aircrews use the LOBL mode of fire to launch missiles after they have locked onto and tracked the properly coded reflected laser energy. The LOBL method requires direct line of sight from the missile to the target. Terminal controllers and aircrews use LOBL when they want to confirm that the aircraft is within launch parameters before launch. LOBL allows a higher probability of kill against obscured or close-range targets. LOBL should be used when the

threat does not require delayed designation (laser countermeasures) or launch from a defilade position.

- **Lock-On After Launch (LOAL).** Aircrews use the LOAL mode of fire to launch missiles without acquiring or locking onto any laser energy. Lock-on occurs after the aircrew launches the missile. LOAL allows the aircrew to launch missiles without exposing themselves to the threat. Three trajectories are available for LOAL launch: low (LOAL LO), high (LOAL HI), direct (LOAL DIR). The trajectory selected depends on terrain obstacles and the distance to the target. The LOAL LO mode allows the missile to clear a low terrain obstacle. The LOAL HI mode allows the missile to climb to a higher altitude to clear a high terrain obstacle. Aircrews use the LOAL DIR mode when the target is within line of sight but enemy countermeasures prevent designation before launch or when the cloud ceiling is low.

### Types of HELLFIRE Delivery

- **Direct Fire.** Direct fire can be used for either the LOBL or LOAL options. The LOBL option requires direct line of sight to the target and seeker lock-on before launch. If the target is not designated by the delivery aircraft, the aircrew can fly behind terrain after missile launch.
- **Indirect Fire.** Aircrews use indirect fire to fire the missile before achieving lock-on (LOAL). The aircrew launches the missile while the aircraft is masked. Aircrews can also use indirect fire when the missile cannot receive the laser energy reflecting off the target because of distance. The aircrew launches the missile in a preprogrammed sequence that causes it to fly an elevated trajectory. The missile then locates and locks onto the laser-reflected energy of the designated target.

### **HELLFIRE Attacks on Multiple Targets**

Multiple missiles attacking multiple high-threat targets reduce aircrew exposure and laser operating time. During multiple launches, the aircrew normally fires the missiles at an 8-second (minimum) interval. Longer intervals can be used based on experience, terrain, target array, and battlefield obscuration. During target attacks, the terminal controller must be sure that subsequent missiles can receive reflected laser energy without interruption. Dust and smoke from initial detonations can block or interrupt the reception of laser energy by follow-on missiles. The terminal controller should consider wind speed and direction when selecting multiple targets. Multiple missile launches require close coordination and timing.

## SECTION VI. RETURN-TO-FORCE

### PROCEDURES

Procedures must be established to allow friendly aircraft to safely move in, out, and through airspace within the area of operations. Planning for friendly air operations to support the MAGTF while concurrently protecting it from enemy air attack is a difficult task. Control procedures must be thoroughly examined, especially for safe passage of friendly aircraft through restricted areas and back through the friendly integrated air defense system. The use of these control procedures should maximize the safety of the defended area while minimizing the possibility of fratricide. Return- to-force (RTF) procedures are based on the threat, friendly posture, friendly aircraft capabilities, and weather. RTF control procedures include the use of:

- Ingress/egress corridors and routes for both helicopters and fixed-wing aircraft (examples of these corridors and routes include low-level transit routes (LLTRs) and minimum risk routes (MRRs))
- Control points
- Visual identification (VID)
- Electronic identification via noncooperative target recognition (NCTR)
- The tactical air navigation (TACAN) system
- IFF equipment
- Altitude and air speed restrictions

- Lame-duck procedures (when aircraft have no communications, no IFF, battle damage, etc.)
- ACAs.

See MCWP 3-22, *Antiair Warfare*, for more information on RTF procedures.

### **DEBRIEFING**

On completing the mission, aircrews should debrief the salient aspects of the flight. The debriefing can provide valuable information by evaluating the mission and its effect on the enemy, enemy resistance, and enemy tactics and techniques. Successes should be highlighted and expanded on to aid in future CAS missions. Difficulties and failures should be identified and the appropriate corrections made to prevent further occurrences. Key points and items of importance should be passed on during the intelligence and operations section debriefs of the aircrew. The information obtained can aid in planning and executing future MAGTF operations.

## Appendix A

# Close Air Support Aircrew Mission Planning Guide

**Note:** This is a notional mission planning guide. It provides a generalized list of planning considerations and information found to be useful by various combat units. *Units should always prepare their own checklists and guidelines, and these should be tailored to their mission, situation, and equipment.*

### CLOSE AIR SUPPORT OVERVIEW

#### Friendly Situation

- Forward line of own troops (FLOT)
- CPs/IPs
- Scheme of maneuver
  - Target area
  - Key terrain
  - Terminal controller position and call sign
  - Supporting arms:
    - (1) Artillery positions

(2) Mortars

(3) NSFS

(4) Gun target lines

• Control Measures:

(1) FSCL/CFL

(2) NFAs

(3) FFAs

(4) RFAs

(5) Missile engagement zone (MEZ)/fighter engagement zone (FEZ) and status

(6) Airspace control areas

## **Intelligence**

- Enemy position and number
  - Projected intent
  - Likely avenues of approach
  - Observed tactics
- Supporting elements
- Threats



- Locations
- Threat guidance (radar/optical/IR systems)
- Threat capabilities
- Indications and warnings
- Employment doctrine

**Weather: Takeoff/Target/Land**

- Ceiling
- Visibility
- Temperature/dew point
- Winds

**Environment**

- Sun azimuth
- Sun elevation
- Sunset time
- Moon azimuth
- Moon elevation
- Percent illumination

- Lux level
- Absolute humidity
- Historical temperature
- Predominant albedos
- Urban lighting

**Mission/Objective**

- Mission statement
- Unit supporting
- Target precedence
- Priority of fires
- Preplanned Missions
  - USMTF
  - Groups/series
  - Search sectors
- TOT/TOS
- Divert authority
- ROEs

## **Control Procedures**

- AOA Entry
  - Routing
  - Altitude/airspeed
  - Available control agencies
  - Air asset deconfliction
  
- CEOI
  - Authentication
  - HAVE QUICK
  - Secure voice
  - Code/procedure words (pro words)
  - Changeover

## **EXECUTION**

### **Ground Procedures**

- Alert posture and upgrades
- Mission tape/cartridge load (DSU/DTUC, etc.)

- NVG eye lane
- AKAC issue/checkout
- Walk time
- Weapons preflight
- Aircraft preflight
- Engine start time
  - INS alignment anomalies
  - Aircraft lighting
  - FLIR checks
  - Built-in test (BIT) checks
- Marshal
- Go/no-go criteria (aircraft and systems)
- Check-in
  - HAVE QUICK checks
  - KY-58/secure voice checks
- Taxi plan
  - Foreign object damage (FOD) prevention
  - NVD checks
- Weapons arming

## **Airborne Transition**

- Takeoff
  - Position
  - Arresting gear
  - Takeoff type
  - Calls
  - Takeoff aborts with ordnance
- Climb out
  - Rendezvous
  - Profile:
    - (1) Altitudes
    - (2) Airspeed
    - (3) Power settings
  - Formation: lookout/scan tasking
  - NVD donning
  - Light package

## **En route**

- C2
  - Primary check-in
  - Alternate check-in
  - Terminology
- Combat checks
  - Sensor boresight
  - Weapon boresight
  - Expendable checks
  - Environmental assessment
  - Radar altimeter check
- Routing
  - Stack/hold/push points
  - Time/fuel management
  - Emitter/lights management

## **Aerial Refueling**

- Time

- Track
- Base altitude/altitude blocks
- Tanker call sign
- Offloads
- Tank window/time on boom/cycle sequence
- Formation procedures
- Post-aerial refueling
- Aerial refueling emergencies

### **Attack Phase**

- Threat zones
- Combat checks
- CAS brief
  - Holding:
    - (1) Profile
    - (2) Formation
    - (3) Tasking/responsibility
    - (4) Deconfliction
  - System interface

- Cadence
- System update
- Terminal control
  - Communications:
    - (1) Required calls
    - (2) Reasonable assurance
  - Restricted run-ins
  - Available marks
  - Laser code/code words
  - Minimum capable TOT
- Attack blueprint
  - Preplanned missions: changes to the plan
  - Immediate missions:
    - (1) Push profile:
      - (a) Formation
      - (b) Tasking
    - (2) Separation:
      - (a) Initiation
      - (b) Geometry/timing



(3) Attack Parameters:

- (a) Lead
- (b) Wingmen

(4) Acquisition Predictions:

- (a) Mark
- (b) Mil size of corrections
- (c) Target scan technique
- (d) Primary sensor
- (e) System aids

(5) Release:

- (a) Parameters
- (b) Mode
- (c) Weapons allocation
- (d) Abort criteria

(6) Off-Target:

- (a) Maneuver
- (b) Expendable
- (c) Cadence
- (d) Routing

(e) Mutual support

(7) Rendezvous:

(a) Profile

(b) Deconfliction

(c) Cadence

- Attack blueprint variations
- Reattack plan
  - Criteria
  - Minimum disengagement:
    - (1) Time
    - (2) Distance
    - (3) Terrain
  - Communication requirement:
    - (1) Interflight
    - (2) Terminal controller
  - Deconfliction

## **Return to Force**

- Rendezvous

- Position
- Profile
- Damage assessment
- Dump target plan
- Combat checklist
- C2
  - Route
  - Profile
  - Tasking
  - Lamé-duck/wounded-bird procedures
  - C2 agencies
  - BDA/S-2 push
  - Integrated Air Defense System (IADS) penetration:
    - (1) IFF/lights/other emitters
    - (2) Air defense warning condition and weapons release status
- Divert/alternate/emergency airfields

## Recovery

- C2
- Recovery type
  - Primary
  - Secondary
- NVD stowage
- Formation break-up
- Landing
  - Primary
  - Secondary
- Darming/safing procedures

## Appendix B

# Planning Considerations for Close Air Support Using Night Vision Goggles and Infrared Pointers

- Can an NVD acquire the target well enough to mark it with an IR marker?
- What will the light conditions be at TOT?
  - Moon phase/rise/set/angle/azimuth/elevation
  - Overall lux level
  - Ambient light sources that will interfere with both the aircrew's and the terminal controller's ability to acquire the target
  - Environmental conditions, including fog, smoke, haze, humidity, and thermal crossover.
- Are any actions planned on the terminal controller's part that will change the light conditions before TOT?
- Are there any actions anticipated by the enemy that will change the light conditions before TOT?
- Will anticipated periods of low visibility negate the use of IR pointers?

- Are the aircrews NVG qualified and have they worked with IR pointers? Do they require a face-to-face permission brief?
- What profile must the aircraft fly to acquire the IR beam?
- Is the background sufficient for the aircrews to acquire the beam?
- Is there a run-in heading or final attack heading that optimizes the ability of the aircrews to acquire the pointer's location, the beam, and the target?
- Does the FAC mark his location with an IR source and/or acquire the aircraft with NVGs? (Does the aircraft have IR lights?)
- Will other activities (attack helicopters) using IR pointers confuse the CAS aircrew?
- Can the strike be conducted under EMCON?
- After this TOT, can IR pointers still be used as a primary mark or should an alternate marking means be used?

## Appendix C

# Aircraft Weapons and Capabilities Guide

**Table C-1. Fixed-Wing Aircraft.**

Aircraft M/D/S	Owning Service	Ordnance	Laser Capability		Marketing Capability	Beacon Capability	Other Systems
			LST	LTD			
AV-8B	USMC	LGBs <sup>1</sup> AGM-65 Maverick General-purpose bombs CBUs <sup>2</sup> Napalm 2.75" rockets 5.00" rockets LUU-2 flares 25-mm cannon AGM-122 Sidearm	Yes	No	Rockets	None	TV NVG GPS
AV-8B "Plus"	USMC	As above	Yes	No	Rockets	None	FLIR LLTV Radar
AC-130H	United States Air Force (USAF) (SOF)	105-mm howitzer 40-mm cannon 20-mm cannon	No	Yes <sup>1</sup>	GLINT 105-mm White-Phosphorous (WP) 105-mm High Explosive (HE) 40-mm MISCH LTD (1688 only)	PPN-19 SST-181 SSB PLS	FLIR LLTV Radar GPS

<sup>1</sup>Although these aircraft can carry and release LGBs, they require off-board designation for terminal guidance.  
<sup>2</sup>CBU = cluster bomb units.

**Table C-1. Fixed-Wing Aircraft (continued).**

Aircraft M/D/S	Owning Service	Ordnance	Laser Capability		Marketing Capability	Beacon Capability	Other Systems
			LST	LTD			
AC-130U	USAF (SOF)	105-mm howitzer 40-mm cannon 25-mm cannon	No	Yes	GLINT 105-mm WP 105-mm HE 40-mm MISCH Codable LTD	SST-181	FLIR ALLTV Radar GPS
F-14 (with LANTIRN)	United States Navy (USN)	LGBs General-purpose bombs 20-mm cannon CBUs Aerial mines LUU-2 flares	No	Yes	Laser WP rockets	None	FLIR GPS NVG Radar
F-15E	USAF	LGBs General-purpose bombs CBUs 20-mm cannon	No	Yes	Laser	PPN-19 PPN-20	FLIR Radar Air-to-air missile (AAM)
F-16 (without LANTIRN)	USAF	AGM-65 Maverick LGBs <sup>1</sup> General-purpose bombs CBUs 29-mm cannon	No	No	WP rockets	PPN-19 PPN-20	Radar GPS <sup>2</sup>
F-16C/D (with LANTIRN)	USAF	LGBs AGM-65 Maverick General-purpose bombs CBUs 20-mm cannon	No	Yes	Laser	PPN-19 PPN-20	FLIR GPS NVG Radar
F/A-18	USN (A/C) USMC (A/C/D)	LGBs AGM-65 Maverick AGM-62 Walleye AGM-84 SLAM AGM-88 HARM JDAM JSOW General-purpose bombs CBUs Aerial mines LUU-2 flares 2.75" rockets 5.00" rockets Napalm 20-mm cannon	Yes	Yes	Laser WP rockets HE rockets	None	FLIR GPS NVG Radar

<sup>1</sup> Although these aircraft can carry and release LGBs, they require off-board designation for terminal guidance.

<sup>2</sup> GPS on some aircraft (Blocks 40/42: 50/52).



**Table C-2. Rotary-Wing Aircraft.**

Aircraft M/D/S	Owning Service	Ordnance	Laser Capability		Marketing Capability	Other Systems
			LST	LTD		
AH-1W	USMC	BGM-71 tube launched, optically tracked, wire command link guided missile (TOW) AGM-114L Hellfire 5" rockets 2.75" rockets 20-mm cannon LUU-2 flares AGM-122 Sidarm	No	Yes	Rockets Laser	FLIR NVG GPS
AH-64A	United States Army (USA)	AGM-114L Hellfire 2.75" rockets 30-mm cannon	Yes	Yes <sup>1</sup>	Laser Rockets	FLIR NVG
AH-64D (including Longbow)	USA	AGM-114L Hellfire 2.75" rockets 30-mm cannon	Yes	Yes <sup>1</sup>	Laser Rockets	FLIR NVG Radar IDM <sup>2</sup> GPS
UH-1N	USMC	2.75" rockets .50 cal machine gun 7.62-mm machine gun (GAU-17)	No	No	Rockets	FLIR NVG GPS
OH-58D (Kiowa Warrior)	USA	AGM-114L Hellfire 2.75" rockets .50 cal machine gun	Yes	Yes	Laser Rockets	FLIR NVG

<sup>1</sup> The AH-64 helicopters cannot designate laser codes 1711 to 1788.  
<sup>2</sup> IDM = improved date modem.

**Table C-3. Aircraft Navigation Capabilities.**

Aircraft M/D/S	Preferred Reference System	MGRS/UTM Capability	Latitudinal/Longitudinal Capability	Offset Data
AH-1W	UTM <sup>1</sup>	None <sup>2</sup>	Yes	None
UH-1N	UTM	None <sup>2</sup>	Yes	None
OH-58D	UTM	8 digits	Degrees, minutes, tenths, hundredths	None
AH-64	UTM	8 digits; need grid zone and spheroid	Degrees, minutes, tenths	Degrees magnetic, meters
AC-130	UTM	8 digits; need grid zone and spheroid	Degrees, minutes, seconds; GPS on all aircraft	Degrees magnetic, meters
AV-8B	UTM	6 digits	Degrees, minutes, tenths	Degrees magnetic, meters
F-14	Latitude/ Longitude		Degrees, minutes, tenths	
F-15E	Latitude/ Longitude	10 digits; conversion faults	Degrees, minutes, thousandths	Degrees true and feet (target to offset)
F-16A	Latitude/ Longitude	6 digits; need latitude/ longitude of 0000 corner of UTM square; conversion faults	Degrees, minutes, tenths	Degrees true and feet (target to offset)
F-16C/D Block 25/30	Latitude/ Longitude	6 digits; need latitude/ longitude of 0000 corner of UTM square; conversion faults	Degrees, minutes, tenths, hundredths	Degrees true and feet (target to offset)
F-16C/D Block 40/50	Latitude/ Longitude	6 digits; need latitude/ longitude of 0000 corner of UTM square; conversion faults	GPS; degrees, minutes, tenths, hundredths, thousandths	Degrees true and feet (target to offset)
F/A-18	Latitude/ Longitude	6 digits; need grid zone and spheroid; degrees, minutes, seconds	Degrees, minutes, seconds	Range: feet, meters, nautical miles or yards; Bearing: degrees true; Elevation: feet, meters

<sup>1</sup> UTM = universal transverse mercator.  
<sup>2</sup> The AH-1W 1686 and UH-1N CDNU aircraft are equipped with GPS.

## **Appendix D**

# **Joint Tactical Airstrike Request**

All U.S. Armed Forces use the JTAR Request Form (DD Form 1972) to request CAS. The use of this form is mandatory unless otherwise authorized by a higher authority. The following paraphrased instructions are included for reference only. A sample JTAR request form is shown in figure D-1.

JOINT TACTICAL AIRSTRIKE REQUEST			See JCS Pub 12, Vol II, for instructions for preparation.	
<b>SECTION I - MISSION REQUEST</b>			DATE	
1. UNIT CALLED	THIS IS	REQUEST NUMBER	TIME	SENT BY
PREPLANNED: <input type="checkbox"/> A PRECEDENCE _____ <input type="checkbox"/> B PRIORITY _____ IMMEDIATE: <input type="checkbox"/> C PRIORITY _____			RECEIVED	
TARGET IS / NUMBER OF <input type="checkbox"/> A PERS IN OPEN _____ <input type="checkbox"/> B PERS DUG IN _____ <input type="checkbox"/> C WPNS/MG/RR/AT _____ <input type="checkbox"/> D MORTARS, ARTY _____ <input type="checkbox"/> E AAA ADA _____ <input type="checkbox"/> F RKTS MISSILE _____ <input type="checkbox"/> G ARMOR _____ <input type="checkbox"/> H VEHICLES _____ <input type="checkbox"/> I BLDGS _____ <input type="checkbox"/> J BRIDGES _____ <input type="checkbox"/> K PILLBOX, BUNKER _____ <input type="checkbox"/> L SUPPLIES, EQUIP _____ <input type="checkbox"/> M CENTER (CP,COM) _____ <input type="checkbox"/> N AREA _____ <input type="checkbox"/> O ROUTE _____ <input type="checkbox"/> P MOVING N S E W _____ <input type="checkbox"/> Q REMARKS _____			TIME	
TARGET LOCATION IS <input type="checkbox"/> A (COORDINATES) _____ <input type="checkbox"/> B (COORDINATES) _____ <input type="checkbox"/> C (COORDINATES) _____ <input type="checkbox"/> D (COORDINATES) _____ <input type="checkbox"/> E TGT ELEV _____ <input type="checkbox"/> F SHEET NO. _____ <input type="checkbox"/> G SERIES _____ <input type="checkbox"/> H CHART NO. _____			CHECKED BY	
TARGET TIME / DATE <input type="checkbox"/> A ASAP _____ <input type="checkbox"/> B NI T _____ <input type="checkbox"/> C AT _____ <input type="checkbox"/> D TO _____				
DESIRED ORD / RESULTS <input type="checkbox"/> A ORDNANCE _____ <input type="checkbox"/> B DESTROY _____ <input type="checkbox"/> C NEUTRALIZE _____ <input type="checkbox"/> D HARASS / INTERDICT _____				
FINAL CONTROL <input type="checkbox"/> A FAC/RABFAC _____ <input type="checkbox"/> B CALL SIGN _____ <input type="checkbox"/> C FREQ _____ <input type="checkbox"/> D ASRT _____ <input type="checkbox"/> E *FREQ _____ <input type="checkbox"/> F FIX / CONT PT _____				
8. REMARKS				
			ACKNOWLEDGED	
			BDE / REGT	
			DIVISION	
			OTHER	

Figure D-1. Joint Tactical Airstrike Request Form.

SECTION II - COORDINATION								
9. NGF	10. ARTY	11. AIO / G - 2 / G - 3						
12. REQUEST <input type="checkbox"/> APPROVED <input type="checkbox"/> DISAPPROVED	13. BY	14. REASON FOR DISAPPROVAL						
15. RESTRICTIVE FIRE PLAN / AIR PLAN [A] IS NOT [B] NUMBER		16. IS IN EFFECT [A] (FROM TIME) _____ [B] (TO TIME) _____						
17. LOCATION [A] _____ [B] _____ (FROM COORDINATES) (TO COORDINATES)		18. WIDTH (METERS)	19. ALTITUDE / VERTEX [A] _____ [B] _____ (MAXIMUM / VERTEX) (MINIMUM)					
SECTION III - MISSION DATA								
20. MISSION NUMBER	21. CALL SIGN	22. NO. AND TYPE AIRCRAFT	23. ORDNANCE					
24. EST / ACT TAKOFF	25. EST TOT	26. CONT PT / RDNVS (COORD / NAVOID FIX)	27. INITIAL CONTACT					
28. FAC/ASRT/TAC(A) CALL SIGN FREQ	29. RESTRICTIVE FIRE / AIR PLAN SEE 15 -19	30. TGT DESCRIPTION	31. TGT COORD /ELEV					
32.								
<table border="1"> <tr><td>ACKNOWLEDGED</td></tr> <tr><td>TUOC</td></tr> <tr><td>CRC</td></tr> <tr><td>TACP</td></tr> <tr><td>ASRT</td></tr> </table>				ACKNOWLEDGED	TUOC	CRC	TACP	ASRT
ACKNOWLEDGED								
TUOC								
CRC								
TACP								
ASRT								

**Figure D-1. Joint Tactical Airstrike Request Form (continued).**

## SECTION I - MISSION REQUEST

<b>Line Title and Elements</b>	<b>Explanation</b>
1    Unit Called	Identifies the unit designation/call sign/preassigned number.
This is	Identifies the request originator by unit designation/call sign/preassigned number.
Request Number	For preplanned missions, indicates the originator's request number in series. For immediate missions, this number is assigned by the ASCS/DASC.
Sent	Indicates the time and the individual who transmitted the request.
2    (Mission categories)	
Preplanned:	
A. Precedence	For preplanned requests, enter precedence (block A) or priority (block B). Precedence is stated numerically in descending order of importance, as determined by the requester. Priority is expressed as shown below.
B. Priority	
Immediate:	
C. Priority	For immediate requests, enter priority (block C). A precedence entry is not required for immediate requests because, by definition, all

		immediate requests have a precedence of 1.
<b>Line Title and Elements</b>	<b>Explanation</b>	
		Use the numerical designation below to determine priority (e.g., define the tactical situation) for preplanned (block B) or immediate (block C):
		1. Emergency: Targets that require immediate action and supersede all other categories of mission priority.
		2. Priority: Targets that require immediate action and supersede routine targets.
		3. Routine: Targets of opportunity. Targets that do not demand urgency in execution.
3	Target is/ Number of	Describes the type, approximate size, and mobility of the target to be attacked. It is necessary to specify, even if a rough estimate, the number of targets (i.e., 10 tanks) or the size of the target area (i.e., personnel on a 500-meter front). Otherwise planners cannot accurately determine what force is required—aircraft numbers/type and ordnance amount/type.
4	Target Location is	Locates the target by using the MGRS prescribed for the area concerned.

<b>Line Title and Elements</b>	<b>Explanation</b>
A. Coordinates	Locates a point target or starting point.
B. Coordinates	When used together with A, provides from ____ to ____ coordinates.
C. Coordinates	When used together with A and B, provides a route.
D. Coordinates	When used together with A through C, provides a route or describes a target area.
E. Target Elevation	Target elevation in feet above sea level.
F. Sheet Number	Self-explanatory.
G. Series	Self-explanatory.
H. Chart Number	Self-explanatory.
Checked	Indicates with whom target information has been cross-checked.
5 Target Time/ Date	Indicates the time/date when the airstrike is requested.
A. ASAP	As soon as possible.
B. NLT	The target is to be attacked before, but not later than (NLT) the time indicated.



<b>Line Title and Elements</b>	<b>Explanation</b>
C. At	Indicates time at which target is to be attacked.
D. To	Denotes the end of the period of time in which support such as airborne alert or column cover is required. When D is used with C, B is unnecessary.
6 Desired Ordnance/ Results	Indicates the requester's desired results. This is essential information for the planner and must be carefully considered by the requester.
A. Ordnance	Desired ordnance.
B. Destroy	Self-explanatory.
C. Neutralize	Self-explanatory.
D. Harass/ Interdict	Self-explanatory.
7 Final Control	Identifies the final controller (FAC, FAC(A), etc.) who will conduct the briefing and control the release of the ordnance.
A. FAC	Transmits the type of terminal control.
B. Call Sign	Call sign of terminal controller.
C. Frequency	Recommended TAD frequency that is

usable on the FEBA.

Line Title and Elements	Explanation
D. Fix/Control Point	Military grid coordinates and/or navigation aid (NAVAID) fix of a control point that is the furthest limit of the attack aircraft's route of flight before control by the final controller.
8 Remarks	Allows incorporation of briefing information not included elsewhere in the request. Enter data for the standard CAS brief.
1. IP/BP _____	
2. Heading _____ MAG: Offset Left/Right	
3. Distance _____	
4. Target Elevation _____ Feet MSL	
5. Target Description _____	
6. Target Location _____	
7. Mark Type _____ Code _____	
8. Friendlies _____	
9. Egress _____	

**SECTION II - COORDINATION**

Line Title and Elements	Explanation
9 NGF	Now known as NSFS.
10 Artillery	Artillery coordination.
11 AIO/G-2/G-3	Air Intelligence Officer, G-2, G-3, or other Service equivalent coordination.

<b>Line</b>	<b>Title and Elements</b>	<b>Explanation</b>
12	Request A. Approved B. Disapproved	Indicates the approval or disapproval of the request.
13	By	Indicates the individual who approved or disapproved the request.
14	Reason for Disapproval	Self-explanatory.
15	Airspace Coordination Plan A. Is Not B. Number	The ACA establishes airspace that is reasonably safe from friendly, surface-delivery, nonnuclear fires. The ACA provides a warning to aircraft of the parameters of surface-delivered fire in a specific area. A plan number or code name is issued, as appropriate.
16	Is in Effect A. From Time ___ B. To Time ___	Establishes the time period that the applicable ACA plan will be in effect.
17	Location A. From Coordinates B. To Coordinates	Grid coordinates of the start/end points of the ACA's centerline.
18	Width (Meters)	Defines the ACA from either side of the centerline.

Line Title and Elements	Explanation
19 Altitude/ Vertex A. Maximum/ Vertex B. Minimum	ACA altitude given in feet above MSL. (Use A for Vertex only entry).

### SECTION III - MISSION DATA

**Note:** Mission data information transmitted to the requesting agency may be limited to those items not included in the request.

Line Title and Elements	Explanation
20 Mission Number	Indicates mission number.
21 Call Sign	Call sign of mission aircraft.
22 Number and Type Aircraft	Self-explanatory.
23 Ordnance	Type of ordnance either by code number or actual nomenclature.
24 EST/ACT Takeoff	Estimated or actual time the mission aircraft will take off.
25 EST TOT	Estimated TOT.
26 Control Point/Rendezvous (Coordinates/ NAVAID Fix)	The furthest limit of the attack aircraft's route of flight before control by the final controller. Same

<b>Line Title and Elements</b>	<b>Explanation</b>
27 Initial Contact	as Line 7, item D, when designated in the request. Indicates the initial control agency the flight is to contact.
28 FAC/TAC(A) Call Sign Frequency	Call sign and frequency of final control agency.
29 ACA	Refer to lines 15 through 19 for this data.
30 Target Description	Self-explanatory.
31 Target Coordinates/ Elevation	Self-explanatory.
32 BDA Report	This optional space is used to record BDA for each mission.
Line 1/ Call Sign	Call sign of the reporting aircraft.
Line 2/ Mission Number	Mission number of the CAS mission for which results are being reported.
Line 3/ Request Number	Requesting unit's request number.
LINE 4/ Location	The location of the target when it was attacked.
Line 5/TOT	The time the aircraft began attack on the target/the time the aircraft completed the mission and departed the target.

<b>Line Title and Elements</b>	<b>Explanation</b>
Line 6/Results	The specific results of the mission. (e.g., "10 tanks destroyed, 150 killed in action ( enemy unit neutralized, mission successful").
Remarks	Other information appropriate to the tactical situation or as requested.

## Appendix E

# Communications Equipment

**Note:** Data contained in this appendix are provided for information. The information given here should be verified before being used operationally.

**Table E-1. Aircraft Communication Equipment.**

<b>Aircraft Type</b>	<b>Radios</b>	<b>Frequency Band<sup>1</sup></b>	<b>Frequency Hopping</b>	<b>Secure Capability</b>
AH-1W	2-AN/ARC-182	Multiple <sup>2</sup>	No	KY-58
	or 2-AN/ARC-210	UHF/VHF-FM	HAVE QUICK II (UHF) SINGARS (VHF-FM)	KY-58
UH-1N	1-AN/ARC-114	VHF-FM	No	KY-58
	1-AN/ARC-159	UHF-AM	No	KY-58
	1- AN/ARC-182	Multiple <sup>2</sup>	No	KY-58
UH-1N CDNU	3-AN/ARC-210	VHF-AM VHF-FM UHF-AM 1-SATCOM	HAVE QUICK II SINGARS	KY-58
OH-58D (Kiowa Warrior)	1-AN/ARC-199	HF	No	KY-75
	1-AN/ARC-201	VHF	SINGARS (FM)	KY-58
	1-AN/ARC-164	UHF	HAVE QUICK II	KY-58
	2-AN/ARC-201	UHF-FM	SINGARS	KY-58
AH-64	1-AN/ARC-164	UHF	HAVE QUICK I	KY-58
	2-AN/ARC-186	VHF <sup>3</sup>	SINGARS (FM)	KY-58

**Table E-1. Aircraft Communication Equipment  
(continued).**

Aircraft Type	Radios	Frequency Band <sup>1</sup>	Frequency Hopping	Secure Capability
AC-130	2-AN/ARC-164	UHF	HAVE QUICK II	KY-58
	1-AN/ARC-164	SATCOM		KY-58
	3-AN/ARC-186	VHF <sup>3</sup>		KY-58
	2-AN/ARC-190	HF		KY-58 KY-75
AV-8B	2-AN/ARC-182	Multiple <sup>2</sup>	No	KY-58
F-14	1-AN/ARC-182	Multiple <sup>2</sup>	HAVE QUICK II	KY-58
	1-AN/ARC-59	UHF	No	KY-58
F-15E	2-AN/ARC-164	UHF	HAVE QUICK II	KY-58
F-16	1-AN/ARC-182	UHF	HAVE QUICK II	KY-58
	1-AN/ARC-164	VHF <sup>3</sup>	No	
F/A-18 <sup>4</sup>	2-AN/ARC-182	Multiple <sup>2</sup>	No	KY-58
	2-AN/ARC-210	VHF UHF	HAVE QUICK II	KY-58

**Legend:**  
 FM: frequency modulation  
 AM: amplitude modulation  
 SATCOM: satellite communications  
 HF: high frequency

**Notes:**  
<sup>1</sup>Frequency bands are as follows:  
 HF: 2.000 - 29.999 MHz in 1-kHz increments.  
 VHF-FM: 29.950 - 87.975 MHz in 25-kHz increments.  
 VHF-AM: 108.000 - 151.975 MHz in 25-kHz increments.  
 UHF: 225.000 - 399.975 MHz in 25-kHz increments.  
<sup>2</sup>The AN/ARC-182 is a multiband radio that operates in any one of four bands: standard VHF-FM, VHF-AM, UHF, or 156.0-173.975 MHz VHF-FM. It can monitor only one band at a time.  
<sup>3</sup>The AN/ARC-186 operates either in the VHF-AM or VHF-FM band. Each radio can monitor only one band at a time.  
<sup>4</sup>F/A-18s are fitted with either two AN/ARC-182 radios or two AN/ARC-210 radios.

**Table E-2. Tactical Air Control Party/Forward Air Controller Communications Equipment.**

		Frequency	Frequency	Secure
--	--	-----------	-----------	--------



Component	Radios	Band <sup>1</sup>	Hopping	Capability
U.S. Army FIST	AN/PRC-77 <sup>2</sup>	VHF-FM		Yes
	AN/PRC-117			
	AN/VRC-12			
	AN/VRC-24			
U.S. Air Force TACP	AN/GRC-206	HF		Yes
		VHF-FM		Yes
		VHF-AM		Yes
		UHF	HAVE QUICK II	Yes
	AN/PRC-77 <sup>2</sup>	VHF-FM		Yes
	AN/PRC-117	VHF-FM	Yes	
	AN/PRC-104	HF		Yes
		VHF-AM		Yes
	UHF	HAVE QUICK II	Yes	
USMC TACP	AN/PRC-77 <sup>2</sup>	VHF-FM		Yes
	AN/PRC-119	VHF-FM	Yes	
	AN/PRC-104	HF		Yes
	AN/PRC-113	VHF-AM		
		UHF		
	AN/VRC-12	VHF-FM		
SOF SOTAC		VHF-FM		Yes
	AN/PRC-117D	VHF <sup>3</sup>		Yes
		UHF <sup>4</sup>		Yes
	AN/PRC-126	VHF-FM		Yes
	LST-5	UHF SATCOM		Yes

**Legend:**  
 FIST: fire support team  
 SOTAC: special operations terminal attack controller

**Notes:**  
<sup>1</sup>Frequency bands for ground radios are as follows:  
 HF: 2.000 - 29.999 MHz in 1-kHz increments.  
 VHF-FM: 29.950 - 75.950 MHz in 50-kHz increments.  
 VHF-AM: 116.000 - 149.975 MHz in 25-kHz increments.  
 UHF: 225.000 - 399.975 MHz in 25-kHz increments.  
<sup>2</sup>The AN/PRC-77 is being phased out of use.  
<sup>3</sup>The AN/PRC-117D VHF-AM/FM frequency range is 116.000 - 173.995 MHz.  
<sup>4</sup>The AN/PRC-117D UHF-AM/FM frequency range is 225.000 - 419.995 MHz.

## Appendix F

# Risk-Estimate Distances

Risk-estimate distances allow commanders to estimate the risk in terms of percent of friendly casualties that may result from an air attack against the enemy. Risk-estimate distances are based on fragmentation patterns. *Risk-estimate distances are for combat use and are not minimum safe distances for peacetime training.* See the FMFM 5-2 series of *Joint Munitions Effectiveness Manuals (JMEMs)* and appropriate Service or command guidance for peacetime restrictions.

### Computations

All attacks are parallel to the FLOT. Distances are computed from the intended impact point of the center of a stick of bombs or a pod of rockets. Deflection distance (from the aiming point toward friendly troops) is built into the risk-estimate distance. The deflection distance equals the distance from the aircraft centerline to the farthest outboard station plus the lateral distance that a weapon travels because of rack-ejection velocity.

### Relationships Between Weapon Impact and Point of Intersection

For all determinations in table F-1 (p. F-4), the position of a prone man was assumed to be on a line perpendicular to the line of flight (or line of weapon impacts) at the midpoint of the line (stick) of weapons. For all sticks of weapons, a weapon was assumed to impact at the point of intersection of these two lines. Thus, for the

weapons evaluated, the following relationships between weapon impact and the point of intersection were assumed:

- **GP bombs.** The center bomb of the stick impacts at the point of the intersection.
- **Rockets.** The center rocket impacts at the point of intersection for an odd number of rockets (e.g., four of seven). The midpoint between the impacts of the center two rockets for an even number of rockets (e.g., rockets two and three of four) is at the point of intersection.
- **Cluster weapons.** The center of the pattern created by the middle CBU is located at the point of intersection.
- **Flamethrower.** The center of the pattern created by the middle round of a single strafe impacts at the point of intersection.
- **Maverick.** Single-weapon delivery impacting at point of intersection.

## Weapon Reliability and Delivery Parameters

A weapon reliability of 1.0 was used for all weapons evaluated and shown in table F-1. Delivery parameters and considerations for specific weapons are in MCRP 5-6.3.7, *Risk Estimates for Friendly Troops (C)*.

## Casualty Criterion

The casualty criterion is the 5-minute assault criterion for a prone soldier in winter clothing and helmet. Physical incapacitation means

that a soldier is physically unable to function in an assault within a 5-minute period after an attack. A probability of incapacitation (PI) value of less than 0.1% can be interpreted as being less than or equal to one chance in one thousand.

**Warning:** Risk-estimate distances do not represent the maximum fragmentation envelopes of the weapons listed.

### Troops in Contact

Unless the ground commander determines otherwise, the terminal controller should regard friendlies within 1 kilometer of targets as a “troops in contact” situation and should advise the ground commander accordingly. However, friendlies outside of 1 kilometer may still be subject to weapon effects. Terminal controllers and aircrews must carefully weigh the choice of ordnance and delivery profile in relation to the risk of fratricide. The ground commander must accept responsibility for the risk to friendly forces when targets are inside the 0.1% PI distance. When ground commanders pass their initials to terminal controllers, they accept the risk inherent in ordnance delivery inside the 0.1% PI distance. Ordnance delivery inside 0.1% PI distances will be considered as “danger close.”

<p><b>Warning:</b> Risk-estimate distances are for <i>combat use</i> and are not minimum safe distances for peacetime training. See JMEMS and appropriate Service</p>
---

or command guidance for peacetime restrictions.

Item	Description	Risk-Estimate Distance (meters)	
		10% PI	0.1% PI
Mk-82 LD	500-lb bomb	250	425
Mk-82 HD	500-lb bomb (retarded)	100	375
Mk-82 LGB	500-lb bomb (guided bomb unit (GBU)-12)	250 <sup>1</sup>	425 <sup>1</sup>
Mk-83 HD	1,000-lb bomb	275	475
Mk-83 LD	1,000-lb bomb	275	475
Mk-83 LGB	1,000-lb bomb (GBU-16)	275 <sup>1</sup>	475 <sup>1</sup>
Mk-84 HD/LD	2,000-lb bomb	325	500
Mk-84 LGB	2,000-lb bomb (GBU- 10/24)	225 <sup>1</sup>	500 <sup>1</sup>
Mk-20 <sup>2</sup>	Rockeye	150	225
Mk-77	500 lb napalm	100	150
CBU-55/77 <sup>2</sup>	Fuel-air explosive (FAE)	___ <sup>1</sup>	___ <sup>1</sup>
CBU-58/71 <sup>2,3</sup>	CBU (all types)	350	525
CBU-87 <sup>2</sup>	CBU (all types)	175	275
CBU-89/78 <sup>3</sup>	CBU (all types)	175	275
2.75" folding-fin aircraft rocket (FFAR)	Rocket with various war-heads	160	200
5" ZUNI	Rocket with various war-heads	150	200
SUU-11	7.62-mm minigun	___ <sup>1</sup>	___ <sup>1</sup>
GAU-12	25-mm gun	100	150

**Figure F-1. Risk-Estimate Distance.**

or command guidance for peacetime restrictions.			
Item	Description	Risk-Estimate Distance (meters)	
		10% PI	0.1% PI
M-4, M-12, SUU-23, M-61	20-mm Gatling gun	100	150
GPU-5A, GAU-8	30-mm Gatling gun	100	150
AGM-65 <sup>5</sup>	Maverick (TV-, IIR-, laser-guided)	25	100
Mk-1/Mk-21	Walleye II (1,000-lb TV-guided bomb)	275	500
Mk-5/Mk-23	Walleye II (2,400-lb TV-guided bomb)	___ <sup>1</sup>	___ <sup>1</sup>
AC-130	105-mm cannon	80 <sup>4</sup>	200 <sup>4</sup>
	40-/25-/20-mm gun	35	125
<p><sup>1</sup>Risk-estimate distances are to be determined. For LGBs, the values shown are for weapons that do not guide and that follow a ballistic trajectory similar to general-purpose bombs. This does not apply to GBU-24 bombs, because GBU-24s do not follow a ballistic trajectory.</p> <p><sup>2</sup>Not recommended for use near troops in contact.</p> <p><sup>3</sup>CBU-71/CBU-84 bombs contain time-delay fuzes that detonate at random times after impact. CBU-89 bombs are antitank and antipersonnel mines and are not recommended for use near troops in contact.</p> <p><sup>4</sup>AC-130 estimates are based on worst-case scenarios. The 105-mm round described is the M-1 high-explosive (HE) round with the M-732 proximity fuze. Other fuzing would result in smaller distances. These figures are accurate throughout the firing orbit. The use of no-fire headings has no benefits for reducing risk-estimate distances and should not be used in contingency situations.</p> <p><sup>5</sup>The data listed applies only to AGM-65 A, B, C, and D models. AGM-65 E and G models contain a larger warhead, and risk-estimate distances are not currently available.</p>			

**Figure F-1. Risk-Estimate Distance (continued).**

## Appendix G

### NATO Close Air Support Formats

<p style="text-align: center;"><b>NATO CHECK-IN BRIEFING (PERMISSIVE ENVIRONMENT)</b></p> <p><b>Aircraft transmits to controller:</b></p> <p>1. Aircraft call sign: _____</p> <p>2. Mission number: _____</p> <p>3. Authentication: _____</p> <p><b>FAC authentication response:</b></p> <p>4. Number and type of aircraft: _____</p> <p>5. Ordnance: _____</p> <p>6. Position: _____</p> <p>7. Playtime: _____</p> <p>8. Abort code: _____</p>
---

**Figure G-1. NATO Check-in Brief (Permissive Environment).**

<p style="text-align: center;"><b>NATO CHECK-IN BRIEFING (UNCERTAIN/HOSTILE ENVIRONMENT)</b></p> <p><b>Aircraft transmits to controller:</b></p> <p>1. Aircraft call sign: _____</p> <p>2. Mission number: _____</p> <p>3. Authentication: _____</p> <p><b>FAC authentication response:</b></p> <p>4. Briefing termination: _____</p>
---

**Figure G-2. NATO Check-in Brief (Uncertain/ Hostile Environment).**



<b>NATO FORWARD AIR CONTROLLER-TO-ATTACK AIRCRAFT BRIEFING</b>	
Mission Call Sign _____	Abort Code _____
<ul style="list-style-type: none"><li>• Note:<ul style="list-style-type: none"><li>• A through J are mandatory brief items, K through O are optional.</li><li>• Items A, D, H, (bolded) are mandatory read back (even if they read "None").</li><li>• Heading and bearings are magnetic unless true headings or bearings are requested.</li></ul></li></ul>	
<b>A. IP</b> _____	
B. Bearing _____	
C. Distance _____	
<b>D. Target location UTM or latitude/longitude</b> _____	
E. Target elevation _____	
F. Target description _____	
G. Mandatory attack heading _____	

**Figure G-3. NATO Forward Air Controller-to-Attack Aircraft Brief.**

<b>H. Friendly forces</b>	
I. Attack time TOT/TTT	_____
J. Attack clearance FAC Call Sign	_____ TAD _____
K. Target indication: Reference Point [ ] Smoke [ ] Light/Mirror[ ]	
Laser code:	_____
Laser-to-target line:	_____
Beacon frequency	_____
Bearing	_____
Distance	_____
Elevation	_____
L. Threats	_____
M. Weather (if significant)	_____
N. Hazards	_____
O. Egress	_____

**Figure G-3. NATO Forward Air Controller-to-Attack Aircraft Brief (continued).**

## Appendix H

# AC-130 Close Air Support Employment

### EXECUTION

This section identifies the basic TTP used by AC-130 aircrews to conduct CAS. Standardized tactics provide a baseline for further refinement and improvement. Commanders should adjust these procedures as the combat situation develops. Aircrews can build on these basic tactics and procedures by using innovative thinking, experience, and information from aircraft tactical manuals to improve CAS for ground combat forces.

#### En Route Tactics

For AC-130 missions the following are mandatory briefing items: in-depth threat brief, marking of friendly locations, identifiable ground features, and ground commander's willingness to accept "danger close."

- **Sensor Alignment/Wet Boresight.** The AC-130 must complete airborne sensor alignment and wet boresight (test fire) procedures before any CAS mission. Only under extreme circumstances will a CAS mission be attempted without performing a sensor alignment/wet boresight. Planners should normally allot 30 minutes for sensor alignment/wet boresight.

- **Ingress Tactics.** The main consideration in selecting en route tactics is the avoidance of enemy detection and fires. AC-130 crews conduct a threat assessment by using all available intelligence data and combine the threat assessment with terrain study to establish the ingress/egress routes, loiter areas, refueling tracks, and altitudes. Medium-altitude ingress reduces fuel consumption and simplifies navigation. When necessary, the AC-130's low-level capability allows ingress/egress through medium-threat hostile territory to arrive in a low-threat objective area.
- **Orbiting.** If no preplanned targets exist, the aircraft will normally proceed to a designated orbit area and await target assignment. Upon arrival at the orbit point, the terminal controller is contacted for ingress instructions.
- **Coordination.** The AC-130 aircrew will establish radio contact while en route to speed acquisition of friendly position(s) and authenticate the terminal controller.
- **CAS Briefing Form.** Aircrews use the AC-130 call-for-fire briefing form (figure H-1) or the standard CAS briefing form (9 line) shown in figure 4-2. In addition to the normal briefing items, the following items are mandatory for AC-130s: a detailed threat description, marking of friendly locations, identifiable ground features, and the ground commander's willingness to accept "danger close."

## Attack Phase

- **Capabilities.** The AC-130 can provide accurate CAS to ground units for extended periods of time during the day or at night. Additionally, the sensor target acquisition capabilities coupled with

ground beacon position marking give the AC-130 a limited all-weather capability.

- **Locating Friendly Positions.** One of the first considerations in the attack phase is to identify friendly positions. Various aids may be used to expedite acquisition (e.g., strobe lights, flares, or IR tape). In addition, there are several electronic beacons that may be used to assist in locating friendly forces. The AC-130 crew will maintain radio contact with the ground forces at all times during firing.
- **Considerations for Close-In Fires.** Because the gunship fire control system is very accurate, ordnance can be delivered very close to friendly positions. However, factors such as ricocheting rounds, the effects of terrain features, and burst pattern should be considered. The greatest hazard to friendly forces is the possibility of ricocheting rounds, and firing down inclined terrain can cause considerable miss distances.
- **Parameters for Attacking the Target.** The type of target, the proximity of friendly forces, and the damage already inflicted will determine the gun selection, the type of ammunition, and the number of firing orbits required to successfully attack the target.
- **Procedures.** The AC-130 has the ability to deliver firepower under conditions of low ceilings and/or poor visibility by using the APQ-150 radar and Black Crow sensors. When employing the AC-130 with radar beacons, the terminal controller gives all target ranges and bearings from the location of the beacon. The beacon should be located as close as practical to the perimeter of the friendly forces. The shorter the offset distance, the more accurate the weapons delivery. For longer offset distances, first round accuracy may be reduced. The AC-130U is not radar-beacon capable, but it is equipped with a strike radar, which gives it a true adverse-weather capability.

1. Observer/warning order: \_\_\_\_\_, This Is \_\_\_\_\_, Fire Mission, Over.  
(AC-130) (terminal controller)
2. Friendly location/mark: My Position \_\_\_\_\_ Marked By \_\_\_\_\_.  
(TRP, grid, etc.) (beacon, IR strobe, etc.)
3. Target location: \_\_\_\_\_  
(bearing (magnetic) and range (meters), TRP, grid, etc.)
4. Target description/mark: \_\_\_\_\_, Marked By \_\_\_\_\_ Over.  
(target description) (IR pointer, tracer, etc.)
5. Remarks: \_\_\_\_\_  
(threats, danger close clearance, restriction, "At My Command", etc.)

**As Required**

1. Clearance: Transmission of the fire mission is clearance to fire. Danger close is 600 m with 105-mm weapons and 125 m with 40-mm, 25-mm, and 20-mm weapons. For closer fire, the observer must accept responsibility for increased risk. State "Cleared Danger Close" on line five. This clearance may be preplanned.

2. At my command: Add "At My Command" on line five. The gunship will call "Ready To Fire" when ready.

3. Adjust Fire: Adjust only for marking rounds or incorrect target. Adjust from impact by giving range (meters) and cardinal (north, south, east, or west) direction.

**Don'ts**

1. Do not ask the gunship to identify colors.
2. Do not reference clock positions.
3. Do not pass run-in headings/no-fire headings.
4. Do not correct left/right or short/long.

**Figure H-1. AC-130 Call for Fire.**

**Egress**

Egress fire support coordination and deconfliction requirements are the same as those for ingress. On mission completion, aircrews follow the egress instructions and either await further mission tasking or return to base.

### NIGHT CLOSE AIR SUPPORT CONSIDERATIONS

The AC-130 gunship can provide accurate fire support for extended periods of time in a night environment. Listed below are considerations for night employment.

- **Sensors.** The AC-130H has a gated laser illuminator for narrow television (GLINT) that is associated with the LLLTV sensor system. The AC-130U has a laser illuminator assembly (LIA) that is associated with the advanced low-light television (ALLTV) sensor system. These are used as an alternate source of IR illumination and have the capability to illuminate and identify IR tape worn by friendly ground forces. The drawback of the GLINT/LIA is that it highlights the aircraft to NVD-equipped enemy forces. When using the AC-130 in a troops-in-contact situation, the friendly position should be located by using one of the following methods:
  - **Marking.** There are a number of methods for marking ground positions. One or more of these methods should be employed to help identify friendly positions.
  - **Beacons.** Electronic beacons can be used in conjunction with the radar to identify and track friendly locations. Offsets from the beacons (these should not exceed 1,500 m for the C-130H model) can be used to help identify targets or to engage targets in poor weather conditions.

- **Visual Markers.** IR/GLINT tape is a very common marker that is used on both troops and vehicles. The tape is usually a good aid in identification, but it requires the use of the GLINT/LIA and can be washed out by surrounding lights. *No more than a 1" x 1" piece of tape on top of the head-gear is needed.* Any extra tends to produce a "halo" effect on the screen. IR pointers are excellent devices for marking both the target and friendly positions. Sometimes it is effective to "snake" the IR spot from the observation point to the target. Strobes are also good marking devices, but they are an active source and therefore not optimum in some situations. Virtually any distinctive light source can also aid in the identification of ground references. Also, thermal markers, such as thermal panels, fuel tabs, fires, and so on, can be used in conjunction with the FLIR device. Thermal markers should be carefully coordinated to eliminate the possibility of ambiguous references.
- **Direction Finding (DF) Homing.** The AC-130 is capable of both VHF/FM and UHF homing. In addition, the AC-130H is equipped with the personnel locator system (PLS). This system can be useful in situations such as combat recovery, where the ground party is unsure of its exact location.
- **Radar Reflectors.** Ground parties can use omnidirectional radar reflectors to aid in covert identification of their position. If multiple reflectors are used in a predetermined pattern, they must be placed at least 10 feet apart.
- **Weather.** Weather is a critical factor when planning for all AC-130 operations. If the ceiling is below 4,500 ft AGL and the aircraft is operating below the ceiling, then only the forward weapons (20-/25-mm) are available. Below 3,000 ft AGL, no weapons are capable of providing fire support.



**(reverse**

## Appendix I

# Glossary

### Section I. Acronyms

A2C2	Army airspace command and control
AAA	antiaircraft artillery
AAGS	Army air-ground system
AAM	air-to-air-missile
ACA	airspace coordination area, also airspace control authority
ACE	aviation combat element
ACT	actual time
AFLNO	Air Force liaison officer
AGL	above ground level
AGM	air-to-ground missile
AIO	air intelligence officer
AIRSUPREQ	air support request
ALLTV	advanced low-light television
AM	amplitude modulation
AMC	air mission commander
AO	air officer
AOA	amphibious objective area
AOC	air operations center (USAF)
AR	attack route, also aerial refueling
AREC	air resource element coordinator
ASAP	as soon as possible
ASC(A)	assault support coordinator (airborne)
ASCS	air support control section
ASOC	air support operations center

ATACS ..... amphibious tactical air control system  
ATCS ..... air traffic control section  
ATF ..... amphibious task force  
ATO ..... air tasking order  
AWC ..... air warfare commander  
BCD ..... battlefield coordination detachment  
BDA ..... battle damage assessment  
BIT ..... built-in test  
BP ..... battle position  
C2 ..... command and control  
C4I ..... command, control, communications, computers,  
and intelligence  
C2W ..... command and control warfare  
CAS ..... close air support  
CATF ..... commander, amphibious task force  
CBU ..... cluster bomb unit  
CEOI ..... communications-electronics operating instructions  
CEP ..... circular error probable  
CFL ..... coordinated fire line  
CID ..... combat identification  
CLF ..... commander, landing force  
COA ..... course of action  
CP ..... contact point  
CRC ..... control and reporting center  
CTOC ..... corps tactical operations center  
CV ..... aircraft carrier  
DASC ..... direct air support center  
DASC(A) ..... direct air support center (airborne)  
DF ..... direction funding  
EA ..... electronic attack  
ECP ..... egress control point  
EMCON ..... emission control  
EO ..... electro-optical  
EOTDA ..... electro-optical tactical decision aid

EP ..... entry point/exit point  
ERP ..... en route point  
EST ..... estimated time  
EW ..... electronic warfare  
FAC ..... forward air controller  
FAC(A) ..... forward air controller (airborne)  
FAE ..... fuel-air explosive  
FARP ..... forward arming and refueling point  
FDC ..... fire direction center  
FEBA ..... forward edge of the battle area  
FEZ ..... fighter engagement zone  
FFA ..... free-fire area  
FFAR ..... folding-fin aircraft rocket  
FFC ..... force fires coordinator  
FFCC ..... force fires coordination center  
FIST ..... fire support team  
FLIR ..... forward-looking infrared  
FLOT ..... forward line of own troops  
FM ..... frequency modulation  
FMFM ..... Fleet Marine Force manual  
FMFRP ..... Fleet Marine Force reference publication  
FO ..... forward observer  
FOB ..... forward operating base  
FOD ..... foreign object damage  
FP ..... firing point  
FRAGO ..... fragmentary order  
FSC ..... fire support coordinator  
FSCC ..... fire support coordination center  
FSCL ..... fire support coordination line  
FSCM ..... fire support coordination measure  
FSE ..... fire support element  
GBU ..... guided bomb unit  
GCE ..... ground combat element  
GCI ..... ground control intercept



LOAL ..... lock-on after launch  
LOAL DIR ..... LOAL direct  
LOAL HI ..... LOAL high  
LOAL LO ..... LOAL low  
LOBL ..... lock-on before launch  
LST ..... laser spot tracker  
LTD ..... laser target designator  
MACCS ..... Marine air command and control system  
MAG ..... Marine aircraft group  
MAGTF ..... Marine air-ground task force  
MARFOR ..... Marine Corps forces  
MARLO ..... Marine liaison officer  
MCDP ..... Marine Corps doctrinal publication  
MCRP ..... Marine Corps reference publication  
MCWP ..... Marine Corps warfighting publication  
MEF ..... Marine expeditionary force  
METT-T ..... mission, enemy, terrain and weather, troops  
and support available, time available  
MEZ ..... missile engagement zone  
MGRS ..... Military Grid Reference System  
MISREP ..... mission report  
MMT ..... Marine air traffic control mobile team  
MRR ..... minimum-risk route  
MSL ..... mean sea level  
NALE ..... naval and amphibious liaison element  
NATO ..... North Atlantic Treaty Organization  
NAVAID ..... navigation aid  
NAVFOR ..... Navy forces  
NCTR ..... noncooperative target recognition  
NFA ..... no-fire area  
NGF ..... naval gunfire (now known as NSFS)  
NLT ..... not later than  
NM ..... nautical mile  
NOE ..... nap-of-the-earth

NSFS ..... naval surface fire support  
NTACS ..... Navy tactical air control system  
NVD ..... night vision device  
NVG ..... night vision goggle(s)  
OAS ..... offensive air support  
OMFTS ..... operational maneuver from the sea  
OPCON ..... operational control  
OPORD ..... operation order  
PGM ..... precision-guided munitions  
PI ..... probability of incapacitation  
PLS ..... personnel locator system  
PP ..... penetration point  
PRF ..... pulse repetition frequency  
prowords ..... procedure words  
PUP ..... pull-up point  
RAOC ..... rear area operations center  
RFA ..... restrictive fire area  
RFL ..... restrictive fire line  
RGR ..... rapid ground refueling  
ROE ..... rules of engagement  
RP ..... rendezvous point  
RTF ..... return to force  
SACC ..... supporting arms coordination center  
SAM ..... surface-to-air missile  
SATCOM ..... satellite communications  
SAW ..... surface-to-air weapon  
SEAD ..... suppression of enemy air defenses  
SINCGARS ..... Single-Channel Ground and Airborne Radio  
System  
SOCCE ..... special operations command and control element  
SOF ..... special operations forces  
SOI ..... signal operating instructions  
SOLE ..... special operations liaison element  
SOP ..... standing operating procedure





VHF-FM ..... very high frequency-frequency modulation  
VID ..... visual identification  
WEZ ..... weapons engagement zone  
WP ..... white phosphorus

## Section II. Terms and Definitions

### A

**air operations center** - The principal air operations installation from which aircraft and air warning functions of combat air operations of the Air Force Component Commander from which command and Services. Also called **AOC**.

**airspace control authority** - The commander designated to assume overall responsibility for the operation of the airspace control system in the airspace control area. (Joint Pub 1-02)

**airspace coordination area** - A three-dimensional block of airspace in a target area, established by the appropriate ground commander, in which friendly aircraft are reasonably safe from friendly surface fires. The airspace coordination area may be formal or informal. (Joint Pub 1-02)

**air superiority** - That degree of dominance in the air battle of one force over another which permits the conduct of operations by the former and its related land, sea and air forces at a given time and place without prohibitive interference by the opposing force. (Joint Pub 1-02)

**air support operations center** - An agency of a tactical air control system collocated with a corps headquarters or an appropriate land force headquarters, which coordinates and directs close air support and other tactical air support. See also **tactical air control center**. (Joint Pub 1-02)

**Army air-ground system** - The Army system which provides for interface between Army and tactical air support agencies of other Services in the planning, evaluating, processing, and coordinating of air support requirements and operations. It is composed of appropriate staff members, including G-2 air and G-3 air personnel, and necessary communication equipment. (Joint Pub 1-02)

## B

**battle damage assessment** - The timely and accurate estimate of damage resulting from the application of military force, either lethal or non-lethal, against a predetermined objective. Battle damage assessment can be applied to the employment of all types of weapon systems (air, ground, naval, and special forces weapon systems) throughout the range of military operations. Battle damage assessment is primarily an intelligence responsibility with required inputs and coordination from the operators. Battle damage assessment is composed of physical damage assessment, functional damage assessment, and target system assessment. Also called **BDA**. (Joint Pub 1-02)

**battle position** - A defensive location oriented on the most likely enemy avenue of approach from which a unit may defend or attack. Such units can be as large as reinforced battalions and as small as platoons. The unit assigned to the battle position is located within the general outline of the battle position, but other forces may operate outside the battle position to provide early detection of enemy forces and all-round security. (FMFRP 0-14)

## C

**close air support** - Air action by fixed- and rotary-wing aircraft against hostile targets which are in close proximity to friendly forces and which require detailed integration of each air mission with the fire and movement of those forces. Also called **CAS**. See also **immediate mission request; preplanned mission request**. (Joint Pub 1-02)

**command and control** - The exercise of authority and direction by a properly designated commander over assigned and attached forces in the accomplishment of the mission. Command and control functions are performed through an arrangement of personnel, equipment, communications, facilities, and procedures employed by a commander in planning, directing, coordinating, and controlling forces and operations in the accomplishment of the mission. Also called **C2**. (Joint Pub 1-02)

**contact point** - 1. (DOD, NATO) In land warfare, a point on the terrain, easily identifiable, where two or more units are required to make contact. 2. (DOD, NATO) In air operations, the position at which a mission leader makes radio contact with an air control agency. 3. (DOD) In evasion and recovery operations, a location where an evader can establish contact with friendly forces. (Joint Pub 1-02)

## **D**

**direct air support center** - The principal air control agency of the U.S. Marine air command and control system responsible for the direction and control of air operations directly supporting the ground combat element. It processes and coordinates requests for immediate air support and coordinates air missions requiring integration with ground forces and other supporting arms. It normally

collocates with the senior fire support coordination center within the ground combat element and is subordinate to the tactical air command center. Also called **DASC**. See also **Marine air command and control system; tactical air command center; tactical air operations center**. (Joint Pub 1-02)

**direct support** - A mission requiring a force to support another specific force and authorizing it to answer directly the supported force's request for assistance. See also **general support**. (Joint Pub 1-02)

## E

**electronic warfare** - Any military action involving the use of electromagnetic and directed energy to control the electromagnetic spectrum or to attack the enemy. Also called EW. The three major subdivisions within electronic warfare are electronic attack, electronic protection, and electronic warfare support. a. electronic attack. That division of electronic warfare involving the use of electromagnetic, directed energy, or antiradiation weapons to attack personnel, facilities, or equipment with the intent of degrading, neutralizing, or destroying enemy combat capability. Also called EA. EA includes: (1) actions taken to prevent or reduce an enemy's effective use of the electromagnetic spectrum, such as jamming and electromagnetic deception, and (2) employment of weapons that use either electromagnetic or directed energy as their primary destructive mechanism (lasers, radio frequency weapons, particle beams, antiradiation weapons). b. electronic protection. That division of electronic warfare involving actions taken to protect personnel, facilities, and equipment from any effects of friendly or enemy employment of electronic warfare that degrade, neutralize, or destroy friendly combat capability. Also called EP. c. electronic warfare support. That division of electronic warfare involving actions tasked

by, or under direct control of, an operational commander to search for, intercept, identify, and locate sources of intentional and unintentional radiated electromagnetic energy for the purpose of immediate threat recognition. Thus, electronic warfare support provides information required for immediate decisions involving electronic warfare operations and other tactical actions such as threat avoidance, targeting, and homing. Also called ES. Electronic warfare support data can be used to produce signals intelligence, both communications intelligence, and electronics intelligence. See also **suppression of enemy air defenses**. (Joint Pub 1-02)

## F

**fire support coordination measure** - A measure employed by land or amphibious commanders to facilitate the rapid engagement of targets and simultaneously provide safeguards for friendly forces. See also **supporting arms coordination center**. (Joint Pub 1-02.)

**fire support coordination center** - A single location in which are centralized communications facilities and personnel incident to the coordination of all forms of fire support. See also **supporting arms coordination center**. (Joint Pub 1-02)

**fire support coordination line** - A line established by the appropriate land or amphibious force commander to ensure coordination of fire not under the commander's control but which may affect current tactical operations. The fire support coordination line is used to coordinate fires of air, ground, or sea weapons systems using any type of ammunition against surface targets. The fire support coordination line should follow well-defined terrain features. The establishment of the fire support coordination line must be coordinated with the appropriate tactical air commander and other supporting elements. Supporting elements may attack targets forward

of the fire support coordination line without prior coordination with the land or amphibious force commander provided the attack will not produce adverse surface effects on or to the rear of the line. Attacks against surface targets behind this line must be coordinated with the appropriate land or amphibious force commander. Also called **FSCL**. (Joint Pub 1-02)

**forward air controller** - An officer (aviator/pilot) member of the tactical air control party who, from a forward ground or airborne position, controls aircraft in close air support of ground troops. (Joint Pub 1-02)

**forward air controller (airborne)** - A specifically trained and qualified aviation officer who exercises control from the air of aircraft engaged in close air support of ground troops. The forward air controller (airborne) is normally an airborne extension of the tactical air control party. Also called **FAC(A)**. (Joint Pub 1-02)

**forward arming and refueling point** - A temporary facility, organized, equipped, and deployed by an aviation commander, and normally located in the main battle area closer to the area of operation than the aviation unit's combat service area, to provide fuel and ammunition necessary for the employment of aviation maneuver units in combat. The forward arming and refueling point permits combat aircraft to rapidly refuel and rearm simultaneously. Also called **FARP**. (Joint Pub 1-02)

**forward looking infrared** - An airborne, electro-optical thermal imaging device that detects far-infrared energy, converts the energy into an electronic signal, and provides a visible image for day or night viewing. Also called **FLIR**. (Joint Pub 1-02) See **night vision device**.

**forward operating base** - An airfield used to support tactical operations without establishing full support facilities. The base may be used for an extended time period. Support by a main operating base will be required to provide backup support for a forward operating base. Also called **FOB**. (Joint Pub 1-02)

## G

**general support** - (DOD, NATO) That support which is given to the supported force as a whole and not to any particular subdivision thereof. (Joint Pub 1-02) See also **direct support**.

## H

**holding point** - A geographically or electronically defined location used in stationing aircraft in flight in a predetermined pattern in accordance with air traffic control clearance. See also **orbit point**. (Joint Pub 1-02)

## I

**immediate air support** - Air support to meet specific requests which arise during the course of a battle and which by their nature cannot be planned in advance. (Joint Pub 1-02)

**immediate mission request** - A request for an airstrike on a target which, by its nature, could not be identified sufficiently in advance to permit detailed mission coordination and planning. See also **preplanned mission request**. (Joint Pub 1-02)



**infrared pointer** - A low power laser device operating in the near infrared light spectrum that is visible with light amplifying night vision devices. Also called **IR pointer**. (Joint Pub 1-02)

**initial point** - 1. The first point at which a moving target is located on a plotting board. 2. A well-defined point, easily distinguishable visually and/or electronically, used as a starting point for the bomb run to the target. 3. airborne—A point close to the landing area where serials (troop carrier air formations) make final alterations in course to pass over individual drop or landing zones. 4. helicopter—An air control point in the vicinity of the landing zone from which individual flights of helicopters are directed to their prescribed landing sites. 5. Any designated place at which a column or element thereof is formed by the successive arrival of its various subdivisions, and comes under the control of the commander ordering the move. (Joint Pub 1-02)

## J

**joint force commander** - A general term applied to a combatant commander, subunified commander, or joint task force commander authorized to exercise combatant command (command authority) or operational control over a joint force. Also called **JFC**. (Joint Pub 1-02)

## M

**Marine air command and control system** - A system which provides the aviation combat element commander with the means to command, coordinate, and control all air operations within an assigned sector and to coordinate air operations with other Services. It is composed of command and control agencies with

communications-electronics equipment that incorporates a capability from manual through semiautomatic control. Also called **MACCS**. See also **direct air support center, tactical air command center; tactical air operations center**. (Joint Pub 1-02)

## **N**

**naval surface fire support** - Fire provided by Navy surface gun, missile, and electronic warfare systems in support of a unit or units tasked with achieving the commander's objectives. Also called **NSFS**. (Joint Pub 1-02)

**night vision device** - Any electro-optical device that is used to detect visible and infrared energy and provide a visible image. Night vision goggles, forward-looking infrared, thermal sights, and low-light-level television are night vision devices. Also called **NVD**. See also **night vision goggle(s); forward-looking infrared**. (Joint Pub 1-02)

**night vision goggle(s)** - An electro-optical image intensifying device that detects visible and near-infrared energy, intensifies the energy, and provides a visible image for night viewing. Night vision goggles can be either hand-held or helmet-mounted. Also called **NVG**. See also **night vision device**. (Joint Pub 1-02)

## **O**

**offensive air support** - Those air operations conducted against enemy installations, facilities, and personnel to directly assist the attainment of MAGTF objectives by the destruction of enemy resources or the isolation of his military force. (FMFRP 0-14)

**orbit point** - A geographically or electronically defined location used in stationing aircraft in flight during tactical operations when a predetermined pattern is not established. See also **holding point**. (Joint Pub 1-02)

## P

**preplanned air support** - Air support in accordance with a program, planned in advance of operations. See **close air support**. (Joint Pub 1-02)

**preplanned mission request** - A request for an airstrike on a target which can be anticipated sufficiently in advance to permit detailed mission coordination and planning. (Joint Pub 1-02) See **close air support**.

## R

**reasonable assurance** - During each close air support mission, an acceptable level of risk under which the supported ground commander allows aircrew to attack targets and release ordnance without positive control. See **fire support coordination center**. (MCRP 5-2C draft)

## S

**supporting arms coordination center** - A single location on board an amphibious command ship in which all communication facilities incident to the coordination of fire support of the artillery, air, and naval gunfire are centralized. This is the naval counterpart to the fire support coordination center utilized by the landing force.

See **fire support coordination center; fire support coordination measure.** (Joint Pub 1-02)

**suppression of enemy air defenses** - That activity which neutralizes, destroys, or temporarily degrades surface-based enemy air defenses by destructive and/or disruptive means. Also called **SEAD.** See also **electronic warfare.** (Joint Pub 1-02)

**synchronized clock** - A technique of timing the delivery of fires by placing all units on a common time. The synchronized clock uses a specific hour/minute based on either local or universal time. Local time is established using the local time zone. (Joint Pub 1-02)

## **T**

**tactical air command center** - The principal U.S. Marine Corps air command and control agency from which air operations and air defense warning functions are directed. It is the senior agency of the U.S. Marine air command and control system which serves as the operational command post of the aviation combat element commander. It provides the facility from which the aviation combat element commander and his battlestaff plan, supervise, coordinate, and execute all current and future air operations in support of the Marine air-ground task force. The tactical air command center can provide integration, coordination, and direction of joint and combined air operations. Also called **Marine TACC.** See also **direct air support center; Marine air command and control system; tactical air operations center.** (Joint Pub 1-02)

**tactical air control center** - The principal air operations installation (ship-based) from which all aircraft and air warning functions of tactical air operations are controlled. Also called **Navy TACC.** (Joint Pub 1-02) See **air support operations center.**

**tactical air control party** - A subordinate operational component of a tactical air control system designed to provide air liaison to land forces and for the control of aircraft. (Joint Pub 1-02)

**tactical air coordinator (airborne)** - An officer who coordinates, from an aircraft, the action of combat aircraft engaged in close support of ground or sea forces. (Joint Pub 1-02)

**tactical air direction center** - An air operations installation under the overall control of the tactical air control center (afloat)/tactical air command center, from which aircraft and air warning service functions of tactical air operations in an area of responsibility are directed. (Joint Pub 1-02)

**tactical air operations center** - The principal air control agency of the U.S. Marine air command and control system responsible for airspace control and management. It provides real time surveillance, direction, positive control, and navigational assistance for friendly aircraft. It performs real time direction and control of all anti-air warfare operations, to include manned interceptors and surface-to-air weapons. It is subordinate to the tactical air command center. Also called **TAOC**. (Joint Pub 1-02) See **Marine air command and control system**.

**terminal control** - 1. The authority to direct the maneuver of aircraft which are delivering ordnance, passengers, or cargo to a specific location or target. Terminal control is a type of air control. 2. Any electronic, mechanical or visual control given to aircraft to facilitate target acquisition and resolution. (Joint Pub 1-02)

**thermal crossover** - The natural phenomenon which normally occurs twice daily when temperature conditions are such that there

is a loss of contrast between two adjacent objects on infrared imagery. (Joint Pub 1-02)

**time on target** - 1. Time at which aircraft are scheduled to attack/photograph the target. 2. The actual time at which aircraft attack/photograph the target. 3. The time at which a nuclear detonation is planned at a specified desired ground zero. (Joint Pub 1-02)

**time to target** - The number of minutes and seconds to elapse before aircraft ordnance impacts on target. (Joint Pub 1-02)

## Appendix J

# References and Related Publications

### Joint Publications (Joint Pubs)

0-2	<i>Unified Action Armed Forces (UNAAF)</i>
1-02	<i>DOD Dictionary of Military and Associated Terms</i>
3-01.4	<i>JTTP for Joint Suppression of Enemy Air Defenses (J-SEAD)</i>
3-02	<i>Joint Doctrine for Amphibious Operations</i>
3-02.1	<i>Joint Doctrine for Landing Force Operations</i>
3-09	<i>Doctrine for Joint Fire Support (under development)</i>
3-09.1	<i>Joint Laser Designation Procedures</i>
3-09.2	<i>JTTP for Ground Radar Beacon Operations (J-BEACON)</i>
3-09.3	<i>JTTP for Close Air Support (CAS)</i>
3-52	<i>Doctrine for Joint Airspace Control in the Combat Zone</i>
3-56.1	<i>Command and Control for Joint Air Operations</i>

### Marine Corps Doctrinal Publications (MCDPs)

1	<i>Warfighting</i>
1-3	<i>Tactics</i>
2	<i>Intelligence</i>
3	<i>Expeditionary Operations</i>

- 5            *Planning*
- 6            *Command and Control*

**Marine Corps Warfighting Publications (MCWPs)**

- 3-16.2        *Techniques and Procedures for Fire Support Coordination*
- 3-22         *Antiair Warfare*
- 3-22.2       *Suppression of Enemy Air Defenses*
- 3-23         *Offensive Air Support*
- 3-25.3       *Marine Air Command and Control System Handbook*
- 3-25.5       *Direct Air Support Center Handbook*
- 3-25.7       *Tactical Air Operations Center Handbook*
- 3-31.1       *Fire Support in Amphibious Operations*
- 5-1          *Marine Corps Planning (under development)*

**Fleet Marine Force Manuals (FMFMs)**

- 1-7           *Supporting Arms in Amphibious Operations*  
(dual designated: NWP 3-09.11M)
- 3-30         *Communications*
- 5-2 Series   *Joint Munitions Effectiveness Manuals (JMEMs) (renumbering as MCRP 5-6 series)*
- 5-40         *Offensive Air Support*
- 5-41         *Close Air Support and Close-In Fire Support*
- 5-45         *Suppression of Enemy Air Defenses*
- 5-50         *Antiair Warfare*
- 5-60         *Control of Aircraft and Missiles*
- 6-8          *Supporting Arms Observer, Spotter, and Controller*



6-18            *Techniques and Procedures for Fire Support Coordination*

**Fleet Marine Force Reference Publications (FMFRPs)**

0-14            *Marine Corps Supplement to DOD Dictionary of Military and Associated Terms*

**Marine Corps Reference Publications (MCRP)**

3-16.8B        *Multiservice Procedures for the Joint Application of Firepower (J-FIRE)*  
3-23A         *The Joint Air Attack Team*  
3-25B         *Multiservice Air-Air, Air-Surface, Surface-Air Brevity Codes*  
5-2C          *Marine Corps Supplement to the DOD Dictionary of Military and Associated Terms (draft)*  
5-6.3.7        *Risk Estimates for Friendly Troops (C)*

**Naval Warfare Publications (NWP)**

3-09.11M      *Supporting Arms in Amphibious Operations (dual designated: FMFM 1-7)*  
3-22.5-AH1,  
Vol. I          *AH-1 Tactical Manual*  
55 Series      *Aircraft Tactical Manuals*